The top half of the page features a complex, abstract background of overlapping, semi-transparent blue triangles and polygons in various shades of blue, creating a dynamic, crystalline effect. This pattern transitions into a clean white background at the bottom.

User Guide  
020-102535-03

**CP2308**

***CHRISTIE***<sup>®</sup>

## NOTICES

### COPYRIGHT AND TRADEMARKS

Copyright © 2018 Christie Digital Systems USA Inc. All rights reserved.

All brand names and product names are trademarks, registered trademarks or trade names of their respective holders.

### GENERAL

Every effort has been made to ensure accuracy, however in some cases changes in the products or availability could occur which may not be reflected in this document. Christie reserves the right to make changes to specifications at any time without notice. Performance specifications are typical, but may vary depending on conditions beyond Christie's control such as maintenance of the product in proper working conditions. Performance specifications are based on information available at the time of printing. Christie makes no warranty of any kind with regard to this material, including, but not limited to, implied warranties of fitness for a particular purpose. Christie will not be liable for errors contained herein or for incidental or consequential damages in connection with the performance or use of this material. Canadian manufacturing facility is ISO 9001 and 14001 certified.

### WARRANTY

Products are warranted under Christie's standard limited warranty, the complete details of which are available by contacting your Christie dealer or Christie. In addition to the other limitations that may be specified in Christie's standard limited warranty and, to the extent relevant or applicable to your product, the warranty does not cover:

- a. Problems or damage occurring during shipment, in either direction.
- b. Projector lamps (See Christie's separate lamp program policy).
- c. Problems or damage caused by use of a projector lamp beyond the recommended lamp life, or use of a lamp other than a Christie lamp supplied by Christie or an authorized distributor of Christie lamps.
- d. Problems or damage caused by combination of a product with non-Christie equipment, such as distribution systems, cameras, DVD players, etc., or use of a product with any non-Christie interface device.
- e. Problems or damage caused by the use of any lamp, replacement part or component purchased or obtained from an unauthorized distributor of Christie lamps, replacement parts or components including, without limitation, any distributor offering Christie lamps, replacement parts or components through the internet (confirmation of authorized distributors may be obtained from Christie).
- f. Problems or damage caused by misuse, improper power source, accident, fire, flood, lightning, earthquake or other natural disaster.
- g. Problems or damage caused by improper installation/alignment, or by equipment modification, if by other than Christie service personnel or a Christie authorized repair service provider.
- h. Problems or damage caused by use of a product on a motion platform or other movable device where such product has not been designed, modified or approved by Christie for such use.
- i. Problems or damage caused by use of a projector in the presence of an oil-based fog machine or laser-based lighting that is unrelated to the projector.
- j. For LCD projectors, the warranty period specified in the warranty applies only where the LCD projector is in "normal use" which means the LCD projector is not used more than 8 hours a day, 5 days a week.
- k. Except where the product is designed for outdoor use, problems or damage caused by use of the product outdoors unless such product is protected from precipitation or other adverse weather or environmental conditions and the ambient temperature is within the recommended ambient temperature set forth in the specifications for such product.
- l. Defects caused by normal wear and tear or otherwise due to normal aging of a product.

The warranty does not apply to any product where the serial number has been removed or obliterated. The warranty also does not apply to any product sold by a reseller to an end user outside of the country where the reseller is located unless (i) Christie has an office in the country where the end user is located or (ii) the required international warranty fee has been paid.

The warranty does not obligate Christie to provide any on site warranty service at the product site location.

### PREVENTATIVE MAINTENANCE

Preventative maintenance is an important part of the continued and proper operation of your product. Failure to perform maintenance as required, and in accordance with the maintenance schedule specified by Christie, will void the warranty. For preventative maintenance schedules, refer to [www.christiedigital.com](http://www.christiedigital.com).

### REGULATORY

The product has been tested and found to comply with the limits for a Class A digital device, pursuant to Part 15 of the FCC Rules. These limits are designed to provide reasonable protection against harmful interference when the product is operated in a commercial environment. The product generates, uses, and can radiate radio frequency energy and, if not installed and used in accordance with the instruction manual, may cause harmful interference to radio communications. Operation of the product in a residential area is likely to cause harmful interference in which case the user will be required to correct the interference at the user's own expense.

CAN ICES-3 (A) / NMB-3 (A)

이 기기는 업무용(A급)으로 전자파적합등록을 한 기기이오니 판매자 또는 사용자는 이점을 주의하시기 바라며, 가정 외의 지역에서 사용하는 것을 목적으로 합니다.

### ENVIRONMENTAL

The product is designed and manufactured with high-quality materials and components that can be recycled and reused. This symbol  means that electrical and electronic equipment, at their end-of-life, should be disposed of separately from regular waste. Please dispose of the product appropriately and according to local regulations. In the European Union, there are separate collection systems for used electrical and electronic products. Please help us to conserve the environment we live in!

# Content

<b>Safety precautions.</b> . . . . .	<b>11</b>
<b>Introduction.</b> . . . . .	<b>13</b>
Projector overview. . . . .	13
Product documentation. . . . .	13
Related documentation. . . . .	13
Contact your dealer. . . . .	14
Key features. . . . .	14
Understanding the Christie touch panel interface. . . . .	15
Technical support. . . . .	16
<b>Operating the projector.</b> . . . . .	<b>17</b>
Turning the projector on or off. . . . .	17
Logging on to the projector. . . . .	17
Logging out of the projector. . . . .	17
Turning the touch panel on or off. . . . .	17
Calibrating the touch panel display. . . . .	18
Turning the lamp on or off. . . . .	18
Opening or closing the douser. . . . .	18
Selecting a channel. . . . .	18
Adding a network time protocol server. . . . .	18
Deleting a network time protocol server. . . . .	19
Changing the time zone. . . . .	19
Changing the time format. . . . .	19
Automatically adjusting the time for Daylight Saving Time. . . . .	20
Manually adjusting the time offset. . . . .	20
Activating marriage. . . . .	20
Changing the orientation of the projected image. . . . .	21
Changing the projector host name. . . . .	21
Changing the temperature display. . . . .	21
<b>Managing lamp settings.</b> . . . . .	<b>22</b>
Adding a new lamp to the lamp history. . . . .	22
Activating a lamp. . . . .	22
Aligning the lamp. . . . .	23

Creating a new Lamp Power/LiteLOC™ file. . . . . 24

Modifying an existing Lamp Power/LiteLOC™ file. . . . . 24

Deleting a Lamp Power/LiteLOC™ file. . . . . 24

Configuring notifications for lamp alarms. . . . . 24

**Managing user accounts. . . . . 26**

    Default user access permissions. . . . . 26

    Adding a user account. . . . . 26

    Changing user account permissions. . . . . 26

    Changing a user account password. . . . . 27

    Deleting a user account. . . . . 27

**Network settings. . . . . 28**

    Connecting the projector to the theater network. . . . . 28

    Connecting the projector to network attached storage. . . . . 28

    Connecting the projector to a media or content network. . . . . 29

    Activating SNMP. . . . . 29

    Downloading MIB information. . . . . 29

**Setting up an integrated media block. . . . . 31**

    Selecting IMB preferences. . . . . 31

    Activating IMB marriage. . . . . 31

**Managing content. . . . . 33**

    Content manager icons. . . . . 33

    Ingesting content and keys. . . . . 33

    Canceling an ingest. . . . . 34

    Viewing remaining NAS storage capacity. . . . . 34

    Filtering content by type. . . . . 34

    Viewing available keys. . . . . 34

    Filtering the key list. . . . . 34

    Deleting local content. . . . . 35

    Deleting keys. . . . . 35

    Collapsing or expanding columns. . . . . 35

    Viewing content details. . . . . 35

    Loading and playing content. . . . . 35

    Unloading content. . . . . 36

**Managing playlists. . . . . 37**

    Creating a new playlist. . . . . 37

Reordering playlist content. . . . .	37
Adding a time offset to a macro. . . . .	37
Replacing playlist content. . . . .	38
Removing playlist content. . . . .	38
Copying a playlist. . . . .	39
Opening an intermission playlist. . . . .	39
Viewing details about playlist content. . . . .	39
Importing a playlist. . . . .	39
Exporting a playlist. . . . .	39
Deleting a playlist. . . . .	40
<b>Working with channels. . . . .</b>	<b>41</b>
Adding a channel for HDMI input. . . . .	41
Adding a channel for IMB input. . . . .	42
Editing an existing channel. . . . .	43
Copying existing channel settings to a new channel. . . . .	43
Changing the active channel. . . . .	44
Viewing the channel list. . . . .	44
Moving a channel up or down the channel list. . . . .	44
Deleting a channel. . . . .	44
<b>Managing color setting files. . . . .</b>	<b>45</b>
Creating a MCGD file. . . . .	45
Editing an existing MCGD file. . . . .	45
Copying existing MCGD file settings to a new file. . . . .	46
Deleting a MCGD file. . . . .	46
Creating a TCGD file. . . . .	46
Editing an existing TCGD file. . . . .	47
Copying existing TCGD file settings to a new file. . . . .	47
Deleting a TCGD file. . . . .	47
<b>Adjusting the image size and position. . . . .</b>	<b>48</b>
Activating the Intelligent Lens System. . . . .	48
Creating a new ILS file. . . . .	48
Calibrating the ILS automatically. . . . .	48
Editing ILS file settings. . . . .	49
Copying existing ILS file settings. . . . .	49
Deleting an ILS file. . . . .	49
Resetting the lens. . . . .	49

Creating a source file. . . . .	50
Editing source file settings. . . . .	50
Copying existing source file settings to a new source file. . . . .	50
Deleting a source file. . . . .	50
Creating a screen file. . . . .	51
Editing screen file settings. . . . .	51
Copying existing screen file settings to a new screen. . . . .	51
Deleting a screen file. . . . .	51
Performing digital convergence. . . . .	52
Resetting digital convergence to the default settings. . . . .	52
<b>Adjusting the image. . . . .</b>	<b>53</b>
Correcting keystone effect. . . . .	53
Correcting dual projector horizontal keystone. . . . .	53
Correcting dual projector vertical keystone. . . . .	54
Correcting vignetting. . . . .	55
Adjusting vertical boresight. . . . .	55
Adjusting horizontal boresight. . . . .	56
Adjusting digital micromirror device convergence. . . . .	58
Adjusting the fold mirror. . . . .	58
Calibrating the color. . . . .	59
Masking the screen edges. . . . .	59
<b>Test patterns. . . . .</b>	<b>61</b>
Displaying a test pattern. . . . .	61
Turning off a test pattern. . . . .	61
Importing a test pattern. . . . .	61
Deleting a test pattern. . . . .	61
<b>Working with the scheduler. . . . .</b>	<b>63</b>
Scheduling a playlist, content, or automation. . . . .	63
Editing a scheduled event. . . . .	63
Copying and pasting an existing scheduled event. . . . .	64
Copying and pasting scheduled events for an entire day. . . . .	64
Cutting and pasting a scheduled event. . . . .	64
Deleting a scheduled event. . . . .	65
Deleting scheduled events for an entire day. . . . .	65
Changing the day of the week the scheduler starts. . . . .	65
Turning the scheduler off. . . . .	65

<b>Managing storage devices. . . . .</b>	<b>66</b>
Adding a new storage device. . . . .	66
Editing storage device settings. . . . .	66
Setting a storage device as a primary drive. . . . .	66
Deleting a storage device. . . . .	67
Adding a remote ingest source. . . . .	67
Editing remote ingest source settings. . . . .	67
Deleting a remote ingest source. . . . .	67
<b>Managing projector setting files. . . . .</b>	<b>69</b>
Creating a 3D file. . . . .	69
Editing an existing 3D file. . . . .	69
Copying a 3D file. . . . .	70
Deleting a 3D file. . . . .	70
<b>Managing audio settings. . . . .</b>	<b>71</b>
Setting the global audio delay. . . . .	71
Setting the audio output rate. . . . .	71
Mapping channels. . . . .	71
Enabling Dolby Atmos. . . . .	72
Editing Dolby Atmos settings. . . . .	72
Disabling Dolby Atmos. . . . .	72
<b>Setting up multiple projectors. . . . .</b>	<b>73</b>
Enabling multiple projectors. . . . .	73
Adding a slave projector. . . . .	73
Enabling content synchronization. . . . .	73
Disabling multiple projectors. . . . .	74
Disabling a slave projector. . . . .	74
Deleting a slave projector. . . . .	74
<b>Automation. . . . .</b>	<b>75</b>
Available macro actions. . . . .	75
Christie ACT actions. . . . .	76
JNIOR actions. . . . .	76
Dolby Cinema processor actions. . . . .	77
SKA-3D actions. . . . .	77
Creating a macro. . . . .	78
Running a macro. . . . .	78

Adding an action item to an existing macro. . . . .	78
Adding a macro to an existing macro. . . . .	78
Deleting a macro. . . . .	79
Adding an automation device to your auditorium. . . . .	79
Modifying automation device settings. . . . .	79
Removing an automation device from your auditorium. . . . .	80
Creating a new playlist trigger. . . . .	80
Editing existing playlist trigger settings. . . . .	80
Deleting a playlist trigger. . . . .	81
Creating a new global trigger. . . . .	81
Editing existing global trigger settings. . . . .	81
Deleting a global trigger. . . . .	81
Importing a device library. . . . .	82
Viewing a device library. . . . .	82
Deleting a device library. . . . .	82
<b>Enhancements and licensing. . . . .</b>	<b>83</b>
Importing a product enhancement. . . . .	83
Enabling an enhancement. . . . .	83
<b>Backup, restore, and upgrade projector files. . . . .</b>	<b>84</b>
Creating a new backup file. . . . .	84
Exporting a backup file. . . . .	84
Importing a backup file. . . . .	84
Sorting backup files by name and date created. . . . .	85
Deleting a backup file. . . . .	85
Adding an upgrade package. . . . .	85
Viewing a list of available upgrade files. . . . .	85
Installing an upgrade package. . . . .	85
Comparing upgrade packages. . . . .	86
Deleting an upgrade package. . . . .	86
Restoring settings from a backup file. . . . .	86
Restoring factory default settings. . . . .	86
<b>Accessing projector diagnostics. . . . .</b>	<b>87</b>
Retrieving and downloading system logs. . . . .	87
Running the projector interrogator. . . . .	87
Downloading a certificate. . . . .	88



**Maintaining the projector. . . . . 89**

- Inspecting ventilation. . . . . 89
- Inspecting and cleaning the lamp. . . . . 89
- Inspecting and cleaning optics. . . . . 90
  - Recommended service kit. . . . . 90
  - Cleaning the lens. . . . . 90
- Installing the lamp. . . . . 91
- Inspecting the card cage filter. . . . . 93
- Inspecting the light engine compartment filter. . . . . 93
- Cleaning a washable filter. . . . . 95
- Replacing the lens. . . . . 96

**Troubleshooting. . . . . 98**

- Projector functionality. . . . . 98
  - Projector does not turn on. . . . . 98
  - Cannot establish communication with projector. . . . . 98
- Lamp functionality. . . . . 99
  - Lamp does not ignite. . . . . 99
  - Lamp suddenly turns off. . . . . 99
  - LiteLOC™ not working. . . . . 100
- Display issues. . . . . 100
  - Flicker, shadows, or dimness. . . . . 100
  - Blank screen with no display of cinema image. . . . . 100
  - Severe motion artifacts. . . . . 101
  - Image is vertically stretched or squeezed. . . . . 101
  - Inaccurate display colors. . . . . 101

**CP2308 Specifications. . . . . 102**

- Physical specifications. . . . . 102
- Power specifications. . . . . 102
- Environmental specifications. . . . . 103
- Display specifications. . . . . 103
- Control signal compatibility. . . . . 104
- Touch panel specifications. . . . . 106
- Lamp specifications. . . . . 106
- Accessories. . . . . 107
- Regulatory. . . . . 108
  - Safety. . . . . 108
  - Electro-magnetic compatibility. . . . . 108

Environmental. . . . .108

# Safety precautions

Observe these important safety rules to avoid personal injury or damage to the projector.

This projector must be operated in an environment that meets the operating range, as listed in the *projector specifications* (on page 102).

## General precautions



**Warning!** If not avoided, the following could result in death or serious injury.

- TRIP OR FIRE HAZARD! Position all cables where they cannot contact hot surfaces, be pulled, be tripped over, or damaged by persons walking on or objects rolling over the cables.
- This product must be installed within a restricted access location not accessible by the general public.
- Only personnel who are trained on the precautions for the restricted access location can be granted entry to the area.
- ELECTRICAL and BURN HAZARD! Use caution when accessing internal components.
- High leakage current present when connected to IT power systems.
- Possible hazardous optical radiation emitted from this product. (Risk group 3 under IEC 62471)
- For protection from ultraviolet radiation, keep all product housings intact during operation.
- UV EXPOSURE! Protective UV safety glasses with side shields and Christie approved protective safety clothing must be worn when performing optical adjustments or servicing the product.
- FIRE AND SHOCK HAZARD! Use only the attachments, accessories, tools, and replacement parts specified by Christie.
- A minimum of four people or appropriately rated lift equipment is required to safely lift, install, or move the product.

## Power



**Warning!** If not avoided, the following could result in death or serious injury.

- SHOCK HAZARD! Only use the AC power cord provided with the product or recommended by Christie.
- FIRE AND SHOCK HAZARD! Do not attempt operation unless the power cord, power socket, and power plug meet the appropriate local rating standards.
- SHOCK HAZARD! Do not attempt operation if the AC supply is not within the specified voltage and current, as specified on the license label.
- SHOCK HAZARD! The AC power cord must be inserted into an outlet with grounding.
- SHOCK HAZARD! Disconnect the product from AC before installing, moving, servicing, cleaning, removing components, or opening any enclosure.
- FIRE HAZARD! Do not use a power cord, harness, or cable that appears damaged.



**Caution!** If not avoided, the following could result in minor or moderate injury.

- Only Christie qualified technicians are permitted to open product enclosures.
- Install the product near an easily accessible AC receptacle.

## Lamp



**Warning!** If not avoided, the following could result in death or serious injury.

- EXPLOSION HAZARD! Lamps and bare bulbs, even when packaged, may explode if dropped or mishandled.
- EXPLOSION HAZARD! Always wear manufacturer approved protective safety clothing (gloves, jacket, face shield) whenever the lamp door is open or when handling the lamp. Any local or federal specifications take precedence over Christie's protective clothing recommendations.
- Do not open the lamp door while the lamp is on.
- EXPLOSION HAZARD! Allow sufficient time for the lamp to cool down before powering down the product, disconnecting it from AC, and opening the lamp door.
- Do not look directly into the lens when the light source is on. The extremely high brightness can cause permanent eye damage.
- FIRE HAZARD! Keep hands, clothes, and all combustible material away from the concentrated light beam of the projector.

# Introduction

This manual is intended for operators of Christie CP2308 projection systems.  
For complete production documentation and technical support, go to [www.christiedigital.com](http://www.christiedigital.com).

## Projector overview

The Christie CP2308 is a compact 3DLP cinema projector suited for theaters with screens up to 10.5 meters (35 feet).

The CP2308 provides an improved user interface and enhanced functionality, supporting future higher speed video interfaces. The projector supports all external 3D systems and can be stacked for dual-projection, 3D presentations.

## Product documentation

For installation, setup, and user information, see the product documentation available on the Christie Digital Systems USA Inc. website. Read all instructions before using or servicing this product.

1. Access the documentation from the Christie website:
  - Go to this URL: <http://bit.ly/2wOIqIS> or <https://www.christiedigital.com/en-us/cinema/cinema-products/digital-cinema-projectors/christie-cp2308>
  - Scan the QR code using a QR code reader app on a smartphone or tablet.

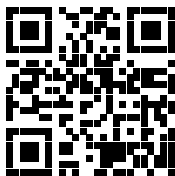

2. On the product page, switch to the **Downloads** tab.

## Related documentation

Additional information on this product is available in the following documents.

- *CP2308 Product Safety Guide (P/N: 020-102536-XX)*
- *CP2308 Installation and Setup Guide (P/N: 020-102534-XX)*
- *CP2308 Serial Commands Guide (P/N: 020-102485-XX)*

## Contact your dealer

Record the information about your installation and keep this information with your records to assist with any servicing of your product. If you encounter a problem, contact your dealer.

<b>Purchase record</b>
Dealer:
Dealer or Christie Sales/Service contact phone number:
Serial number: The serial number can be found on the license label located on the display panel.
Purchase date:
Installation date:

## Key features

Understand the important features of the projector.

- Playback of cinema video, audio, and timed text
- Touch panel with 1280 X 800 resolution
- 3D ready
- DCI compliant
- Four options for Xenon lamps
- Third-party IMB support
- Motorized lens mount
- High Frame Rate capable
- Standard support for High-bandwidth Digital Content Protection (HDCP)
- Content intake through USB 2.0, USB 3.0, or eSATA ports
- HDMI 1.4
- Support for multi-projector playback
- Simple Network Management Protocol (SNMP) support for remote status monitoring

# Understanding the Christie touch panel interface

Use the touch panel to control the projector and perform functions such as turning the light on or off, selecting channels, and viewing status information.

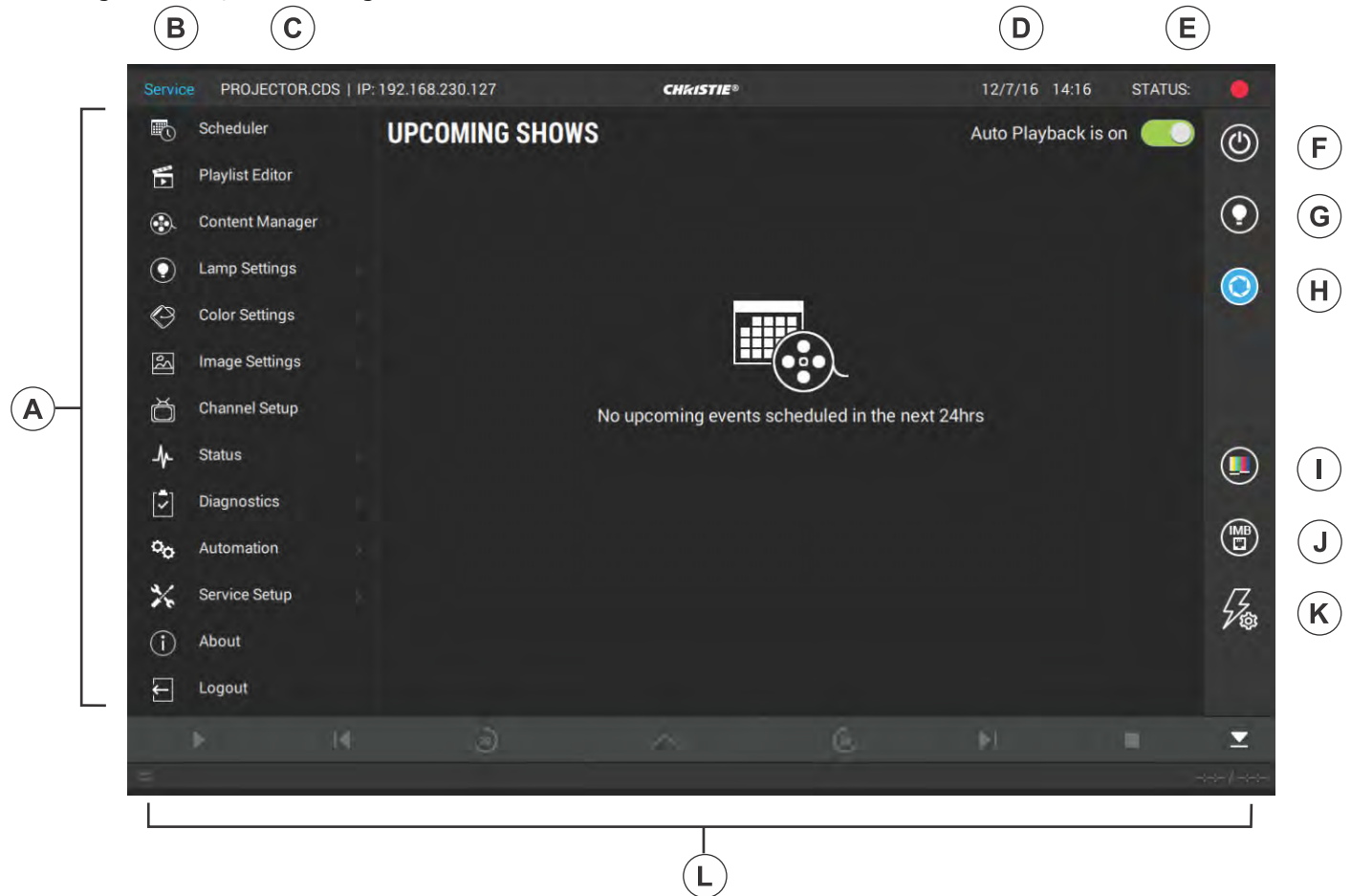

A	Left navigation menu. Your access permissions determine the available options.	G	Turns the light on or off.
B	Current access permissions.	H	Opens and closes the douser.
C	Projector name and IP address.	I	Turns test patterns on or off.
D	Current date and time.	J	Displays channels.
E	System status. To display all alarms, tap the colored icon.	K	Displays macros.
F	Turns the projector on or off.	L	Playback controls. See <i>Loading and playing content</i> (on page 35).

## Technical support

Technical support for Christie products is available at:

- North and South America: +1-800-221-8025 or [Support.Americas@christiedigital.com](mailto:Support.Americas@christiedigital.com)
- Europe, Middle East, and Africa: +44 (0) 1189 778111 or [Support.EMEA@christiedigital.com](mailto:Support.EMEA@christiedigital.com)
- Asia Pacific: +65 6877-8737 or [Support.APAC@christiedigital.com](mailto:Support.APAC@christiedigital.com)
- Christie Managed Services: +1-800-550-3061 or [NOC@christiedigital.com](mailto:NOC@christiedigital.com)



# Operating the projector

This section describes how to operate the projector and adjust projector settings.

## Turning the projector on or off

Turn the projector on to display content, or turn the projector off to conserve energy.

- In the right toolbar, tap and hold **Power**. 

## Logging on to the projector

Log on to the projector to access projector menus.

1. Tap **Login**.
2. In the User list, select a user name.
3. Enter your password.
4. Tap **Login**.

## Logging out of the projector

Log out of the projector to restrict access to projector menus or to change access permissions.

- Tap **Logout**.

## Turning the touch panel on or off

Turn the touch panel on to view projector menus, or turn the touch panel off to conserve energy.

- To turn the touch panel on or off, press the power button (A) on the top of the touch panel.

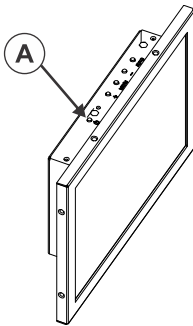

## Calibrating the touch panel display

Calibrate the touch panel to improve its appearance and responsiveness to touch commands.

1. Log on to the projector.
2. In the left navigation menu, tap **Service Setup** > **Preferences**.
3. Tap **Touch Panel**.
4. To calibrate the touch panel, tap **Start Calibration**.

## Turning the lamp on or off

Turn the lamp on to display content or view test patterns, turn the lamp off to extend lamp life.

- To turn the lamp on or off, in the right toolbar, tap and hold **Lamp**. 



## Opening or closing the douser

Open the douser to display light on the screen, or close the douser to remove light from the screen.

- In the right toolbar, tap and hold **Douser**. 

## Selecting a channel

Create channels to store customized projector settings for different inputs.

1. In the right toolbar, tap **Channels**.   
The Channels window displays the available channels.
2. Tap a channel.  
In the Channel Setup panel, a green checkmark  indicates the active channel.

## Adding a network time protocol server

Add a network time protocol (NTP) server to synchronize the time on all installed projectors in the same region.

1. In the left navigation menu, tap **Service Setup** > **Time Setup**.
2. Tap the **Time Sync using NTP Server** slider.  
The color of the slider changes to green to indicate it is active.
3. Tap **+ New NTP Server**.
4. Select a local or a public NTP server:
  - To use a local NTP server, tap **Local Server** and type the IP address in the IP Address field.
  - To use a public NTP server, tap **Public Server** and complete the Country and Server fields.
5. To test the connection, tap **Test**.

6. Tap **Add**.

## Deleting a network time protocol server

Remove a network time protocol (NTP) server if you do not need to synchronize the time on all installed projectors in the same region.

1. In the left navigation menu, tap **Service Setup > Time Setup**.
2. If network time protocol (NTP) time synchronization is not active, tap the **Time Sync using NTP Server** slider.  
The color of the slider changes to green to indicate it is active.
3. In the NTP Server Address list, tap an NTP server.
4. Tap **Delete**. 
5. Tap **Delete**.

## Changing the time zone

Change the time zone settings to make the projector time match the local time zone.

1. In the left navigation menu, tap **Service Setup > Time Setup**.
2. Tap the **Time Zone** tab.
3. In the Region list, select a region.
4. In the Time Zone list, select the time zone.
5. Select a time format.
6. Tap the **Automatically adjust for Daylight Savings** slider to automatically adjust the time to daylight savings.  
The color of the slider changes to green to indicate it is active.
7. Tap **Save**.

## Changing the time format

You can use the 12-hour or 24-hour format to display projector time. The 24-hour format reduces ambiguity.

1. In the left navigation menu, tap **Service Setup > Preferences**.
2. Tap **General**.
3. In the System area, select a time format option:
  - To use the 12-hour format, tap **12 Hours**.
  - To use the 24-hour format, tap **24 Hours**.

## Automatically adjusting the time for Daylight Saving Time

With automatically adjusted time settings, there is no need to update the projector time when Daylight Saving Time occurs.

1. In the left navigation menu, tap **Service Setup** > **Time Setup**.
2. Tap the **Time Zone** tab.
3. To automatically adjust the projector time to follow Daylight Saving Time, tap the **Automatically adjust for Daylight Savings** slider. The color of the slider changes to green to indicate it is active.
4. Tap **Save**.

## Manually adjusting the time offset

You cannot manually adjust the time offset if network time protocol (NTP) time synchronization is active.



To turn off NTP time synchronization, tap the **NTP Servers** tab and then tap the **Time Sync via NTP Server** slider. The color of the slider changes to gray to indicate it is inactive.

1. In the left navigation menu, tap **Service Setup** > **Time Setup**.
2. Tap the **SM Time Adjust** tab.
3. Increase or decrease the time offset:
  - To increase the offset in minutes and seconds, tap **Up**. ^
  - To decrease the offset in minutes and seconds, tap **Down**. v

The Digital Cinema Initiatives (DCI) specification does not allow time offsets greater than six minutes in a calendar year.

4. Tap **Save**.

## Activating marriage

You must complete marriage to display content and to comply with the Digital Cinema Initiatives (DCI) specification.



You cannot complete marriage remotely.

1. In the left navigation menu, tap **Service Setup** > **Marriage Setup**.
2. Tap **Start** and complete the Marriage Setup wizard.
3. Tap **Finish**.

## Changing the orientation of the projected image

Change the orientation of the projected image from normal to inverted to support multi-projector installations where deflection mirrors are used.

1. In the left navigation menu, tap **Service Setup > Preferences**.
2. Tap **General**.
3. From the Projected Image Orientation list, select the required orientation for the projected image.

Orientation	Description
Normal Front	Projection from behind the audience with the projector in the normal, upright position.
Inverted Front	<p>Projection from behind the audience with the projector in an inverted position (upside down).</p> <p> Inverted positioning is not supported for CP2308 projectors. For more information, see the <i>CP2308 Installation and Setup Manual</i>.</p>
Normal Rear	Projection from behind the screen with the projector in the normal, upright position.
Inverted Rear	<p>Projection from behind the screen with the projector in an inverted position (upside down).</p> <p> Inverted positioning is not supported for CP2308 projectors. For more information, see the <i>CP2308 Installation and Setup Manual</i>.</p>

## Changing the projector host name

Change the projector host name to make it easier to identify.

1. In the left navigation menu, tap **Service Setup > Preferences**.
2. Tap **General**.
3. In the Projector Hostname field, type a name.
4. Tap **Update**.

## Changing the temperature display

Set the touch panel to display temperatures in Celsius or Fahrenheit degrees.

1. In the left navigation menu, tap **Service Setup > Preferences**.
2. Tap **General**.
3. In the Temperature Units list, select **Celsius** or **Fahrenheit**.

# Managing lamp settings

Learn how to set up and work with a lamp.

This section provides information and procedures for optimizing lamp performance. Optimizing lamp performance is recommended to make sure you receive the brightest, most uniform image possible for the life of the lamp.

## Adding a new lamp to the lamp history

Add a new lamp to make it available for activation.



Before adding a new lamp to the lamp history, you must turn off the existing lamp.

1. From the left navigation menu, tap **Lamp Settings > Lamp Manager**
2. Tap **+ New Lamp**.
3. In the New Lamp dialog, select the type of lamp you want to add.
4. In the Serial field, type the serial number of the new lamp.
5. In the Reason for Change list, select the reason for adding the new lamp.
6. In the Lamp Hours Used field, type the number of hours the lamp has been used, if applicable.
7. In the Max Lamp Hours field, type the estimated maximum lamp hours.  
The value for Hours Remaining is calculated automatically based on the specified hours used and the maximum lamp hours.
8. Tap **Add**.

## Activating a lamp

Activate a new lamp for your projector when replacement is required.



If there is an active lamp, you must turn it off before activating a new lamp.

1. In the left navigation menu, tap **Lamp Settings > Lamp Manager**.
2. From the Lamp History list, select the lamp you want to activate.
3. In the Activate Lamp dialog, select the reason for activating the lamp.
4. For the Total Lamp Hours Used value, tap the up and down arrows to enter the number of hours the lamp has been used, if applicable.  
The hours remaining are calculated automatically based on the specified hours used and the maximum lamp hours.
5. Tap **Activate**.

## Aligning the lamp

Complete the following procedure to align the lamp.

1. In the left navigation menu, tap **Lamp Settings > Lamp Power/LiteLOC Setup**.
2. Under Lamp Power, verify that the lamp power settings are suitable for your requirements.
3. In the left navigation menu, tap **Lamp Settings > Lamp Adjust**.
4. Tap the **Display White Test Pattern** slider.
5. Complete a coarse lamp adjustment.
  - a) Locate the Y axis adjustment label on the operator side of the projector

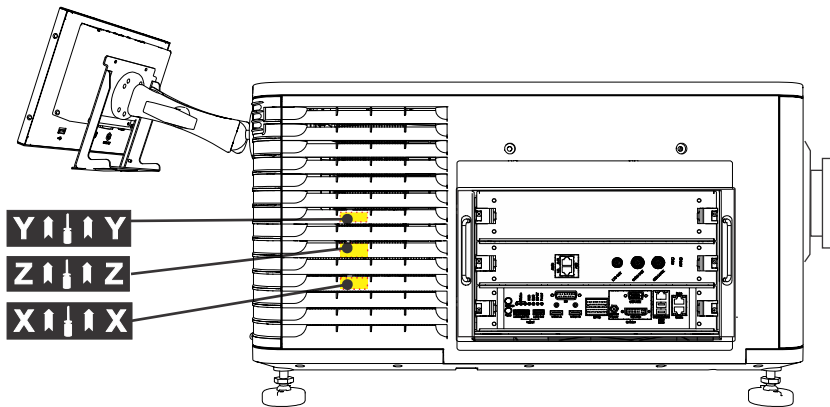

- b) Insert a 5 mm hex driver through the louvers at an angle below the Y axis adjustment label until it is firmly seated on the Y axis adjustment screw.

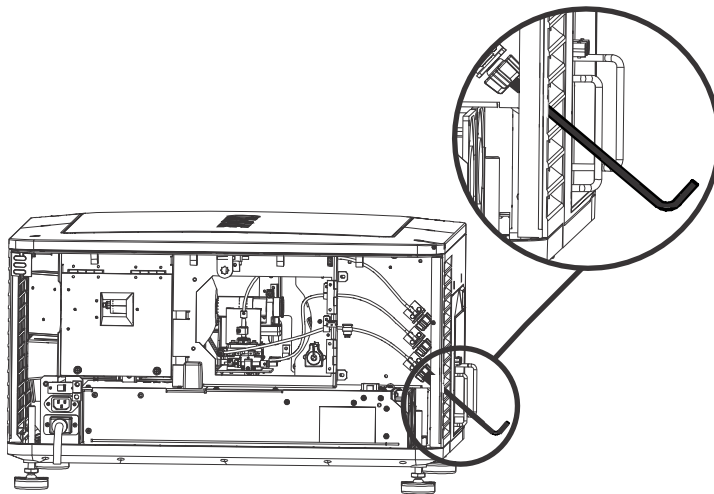

- c) Turn the screw clockwise or counterclockwise until the value in the Intensity field peaks and then reduces.
  - d) Remove the hex driver and repeat steps a to c to adjust the Z and X axis.
6. Complete a fine lamp adjustment.
  - a) Locate the Y axis adjustment label on the operator side of the projector.
  - b) Insert a 5 mm hex driver through the louvers at an angle below the Y axis adjustment label until it is firmly seated on the Y axis adjustment screw.

- c) Turn the screw slowly clockwise or counterclockwise until you determine the highest value.
- d) Remove the hex driver and repeat steps a to c to adjust the Z and X axis.
7. Verify the value in the Intensity field is greater or equal to the required lamp power percentage. If value is lower, repeat steps 5 and Step 6.

## Creating a new Lamp Power/LiteLOC™ file

Create a new Lamp Power/LiteLOC™ file to save lamp power settings for different content.

1. In the left navigation menu, tap **Lamp Settings > Lamp Power/LiteLOC Setup**.
2. In the Lamp Power/LiteLOC™ Setup pane, tap **Create**. 
3. In the Create dialog, type the name for your new file and tap **Create**.
4. Under Lamp Power, tap the plus and minus signs to select the power setting for the lamp.
5. Tap **Save**.

## Modifying an existing Lamp Power/LiteLOC™ file

Modify the settings in the Lamp Power/LiteLOC™ file to change lamp power.

1. In the left navigation menu, tap **Lamp Settings > Lamp Power/LiteLOC Setup**.
2. In the Lamp Power/LiteLOC™ File list, select the lamp file to modify.
3. Under Lamp Power, tap the plus and minus signs to modify the power settings for the lamp.
4. Tap **Save**.

## Deleting a Lamp Power/LiteLOC™ file

Delete a Lamp Power/LiteLOC™ file when it is no longer required.

1. In the left navigation menu, tap **Lamp Settings > Lamp Power/LiteLOC Setup**.
2. In the Lamp Power/LiteLOC™ File list, select the file to delete.
3. Tap **Delete**. 
4. To confirm the deletion, tap **Delete**.

## Configuring notifications for lamp alarms

Select the options to receive notification for lamp expiration, lamp half-life, and LiteLOC™ performance issues.

1. In the left navigation menu, tap **Service Setup > Preferences**.
2. Tap **Alarm Triggers**.
3. In the right pane, choose from the following options:
  - To receive notification of that the lamp is approaching expiration, tap the **Lamp Expiration** slider.



- To receive notification that the lamp is approaching its half life, tap the **Lamp Half-life** slider.
- To receive notification that the configured LiteLOC™ intensity cannot be attained, tap the **LiteLOC Intensity Unattainable** slider.

The slider turns green when the option is activated.

# Managing user accounts

Learn how to create new user accounts, how to modify the properties of those accounts, and how to remove the accounts. A user account is a set of credentials consisting of both a user name and password that allows access to a projector settings.

## Default user access permissions

This table lists the Christie touch panel access permissions.

Permission	Description
installer	Can define Ethernet settings (IP network address), restore backup files, and upgrade the system software.
manager	Can activate channels and test patterns, view detailed diagnostic logs for in-depth troubleshooting and view server errors. This is the default level.
marriage	Can access all touch panel windows. Can authorize projector marriage.
operator	Can view basic projector status, diagnostic information and software version information. This is the default level for Serial Communication sessions.
service	Can access all touch panel windows. Cannot authorize projector marriage.

## Adding a user account

Adding a user account allows users to access projector menus.

1. In the left navigation menu, tap **Service Setup > User Accounts**.
2. Tap **+ Add User**.
3. Complete the Name, Permissions, New Password, and Confirm Password fields.
4. Tap **Add**.

## Changing user account permissions

Change user account permissions to limit or increase access to projector menus and functionality.

1. In the left navigation menu, tap **Service Setup > User Accounts**.
2. In the left pane, tap a user account.
3. In the Permissions list, select a new permissions setting.
4. Tap **Save**.

## Changing a user account password

Periodically change a user account password to limit access to projector menus and functionality to authorized users.

1. In the left navigation menu, tap **Service Setup > User Accounts**.
2. In the left pane, tap a user account.
3. Tap **Change password**.
4. Complete the New Password and Confirm Password fields.
5. Tap **Save**.

## Deleting a user account

Delete a user account to prevent access to projector menus and functionality.

1. In the left navigation menu, tap **Service Setup > User Accounts**.
2. In the left pane, tap a user account.
3. Tap **Delete**. 
4. To confirm the deletion, tap **Delete**.

# Network settings

Learn how to connect the projector to media devices and wired networks.



The system provides the MAC address of the projector automatically.

## Connecting the projector to the theater network

Connect the projector to the theater network to control it remotely and allow it to communicate with other network devices.

1. Connect the Ethernet cable from the theater network to the **Management** port on the input panel.
2. In the left navigation menu, tap **Service Setup** > **Network Settings**.
3. In the Port list, tap **Management**.
4. Enter the network settings:
  - To obtain the network settings automatically, tap **Automatic**.
  - To enter the settings manually, tap **Manual** and complete these fields:

Field	Description
IP Address	The IP address of the projector.
Subnet Mask	The subnet mask to which the IP address belongs.
Gateway	The IP address for the network gateway.
Primary DNS	The IP address of the primary DNS server.
Secondary DNS	The IP address of the secondary DNS server.

5. Tap **Save**.

## Connecting the projector to network attached storage

To ingest and play content, a network attached storage (NAS) device must be connected to the projector.

1. Connect the NAS device to the NAS port on the input panel.
2. In the left navigation menu, tap **Service Setup** > **Network Settings**.
3. In the Port list, tap **Content-NAS**.
4. Enter the network settings:
  - To obtain the network settings automatically, tap **Automatic**.

- To enter the settings manually, tap **Manual** and complete the IP Address and Subnet Mask fields.
5. Tap **Save**.

## Connecting the projector to a media or content network

Connect the projector to a media or content network to play content.

1. In the left navigation menu, tap **Service Setup** > **Network Settings**.
2. In the Port list, tap **Media**.
3. Enter the network settings:
  - To obtain the network settings automatically, tap **Automatic**.
  - To enter the settings manually, tap **Manual** and complete the IP Address and Subnet Mask fields.
4. Tap **Save**.

## Activating SNMP

Activate the Simple Network Management Protocol (SNMP) to monitor the theater network for conditions that indicate communication or hardware failures.

1. In the left navigation menu, tap **Service Setup** > **Network Settings**.
2. Tap the **SNMP** tab.
3. Tap the **SNMP** slider.  
The color of the slider changes to green to indicate it is active.
4. In the SNMP Settings area, select a SNMP version.
5. Complete the Trap Receiver IP fields.  
A trap receiver captures, displays, and logs SNMP traps. Traps are event notices that are sent immediately to the trap receiver from a network device. The SNMP device does not need to use resources to poll for these event notices.
6. In the Blocked SNMP Traps area, select the SNMP traps you want to block.
7. Tap **Save**.

## Downloading MIB information

A Management Information Base (MIB) file contains the definitions for the device being managed by the SNMP protocol.

1. In the left navigation menu, tap **Service Setup** > **Network Settings**.
2. Tap the **SNMP** tab.
3. Tap **Download MIB**.
4. Browse to the location where you want to save the MIB file.

5. In the Name field, type a name for the MIB file.
6. Tap **Accept**.
7. Tap **OK**.

# Setting up an integrated media block

You can configure CP2308 to work with different models of integrated media blocks, including the Christie IMB.

## Selecting IMB preferences

Choose from the available options to set the type of integrated media block (IMB).

1. To set the type of IMB, tap **Service Setup** > **Preferences**.
2. Tap **IMB**.
3. In the type list, select the type of IMB you are using.  
The system prompts you to reboot the projector.
4. To apply the changes, tap **Reboot**.
5. After the projector has restarted, log in with your user account.

## Activating IMB marriage

After selecting the IMB type, you must install the IMB and complete marriage to display secure content. You cannot complete marriage remotely.

The marriage wizard requires you to confirm that the IMB has not been tampered with.

1. Install the IMB in the available slot on the projector.  
For more information, see the *Christie IMB-S3 Installation and Setup Manual* (P/N: 020-102582-XX) or the documentation provided by the IMB manufacturer.
2. In the left navigation menu, tap **Service Setup** > **Marriage Setup**.
3. Tap **Start** and confirm that the security manager (SM), service door, and marriage ring are secure.
4. Tap **Next** and complete the marriage checklist, confirming that the following are secure:
  - All fan clips are tightened on the four fan pack at the front of the light engine compartment.
  - Fan pack spring pins are locked in place to prevent removal of the light engine fan pack.
  - Projector front cover is installed.
5. Tap **Next** and enter the Marriage user and password credentials.
6. Tap **Login**.
7. To start the marriage process, press the Marriage button on the projector within 30 seconds.

The system starts the marriage process and indicates when the process is completed successfully.

8. Tap **Finish**.









# Managing content

Use the procedures in this section to manage content and keys.

## Content manager icons

These icons appear in the content manager.

Icon	Description
	The content is presented in flat format.
	The content is presented in scope format.
<b>2D</b>	2D content identifier.
	3D content identifier.
	A subtitle file is included with the content.
	A closed captioning file is included with the content.
<b>2K</b>	2K content identifier.
<b>4K</b>	4K content identifier.
<b>ATMOS</b>	The content includes a Dolby Atmos audio file.
	High frame rate identifier.
	Extended Dynamic Range (EDR) content.

## Ingesting content and keys

To ingest content, an ingest device must be connected to the projector. The ingest device must be properly configured and operating correctly.

1. In the left navigation menu, tap **Content Manager**.
2. Tap the **Ingestible Content** tab.
3. In the Source list, select a source for the content.  
Ingest devices connected to the projector are automatically added to the Source list.
4. Tap **Refresh**. 
5. In the Show list, select the content type.
6. Select the checkbox to the left of the content you want to ingest, or select the empty check box at the top of the column to select all content.

7. Tap **Ingest**.
8. To view the ingest progress, tap the **Progress** tab.

## Canceling an ingest

Cancel an ingest if the ingest is taking too long, or if the content has been ingested previously.

1. Through the Content Manager, run an operation to ingest content and keys. See *Ingesting content and keys* (on page 33).
2. Tap the **Progress** tab.
3. Select the checkbox to the left of the content.
4. Tap **Cancel**.

## Viewing remaining NAS storage capacity

View the remaining NAS storage capacity to determine if additional storage is required.

1. In the left navigation menu, tap **Content Manager**.
2. Review the remaining storage capacity displayed on the **Local Content** tab.

## Filtering content by type

Filter content by type to locate content of a specific type or reduce the return results.

1. In the left navigation menu, tap **Content Manager**.
2. On the **Local Content** tab in the Show list, select the content type.

## Viewing available keys

Keys are required to play encrypted content.

1. In the left navigation menu, tap **Content Manager**.
2. To view the available keys, tap the **Keys** tab.

## Filtering the key list

Filter the key list to locate keys of a specific type.

1. In the left navigation menu, tap **Content Manager**.
2. Tap the **Keys** tab.
3. In the Show list, select one of the following options for filtering the list:
  - All Keys
  - Not Yet Valid
  - Valid

- Expiring Soon
- Expired

## Deleting local content

Delete local content to increase local storage space.

1. In the left navigation menu, tap **Content Manager**.
2. Select the check box to the left of the content on the **Local Content** tab, or select the empty check box at the top of the column to select all content.
3. Tap **Delete**.
4. To confirm the deletion, tap **Delete**.

## Deleting keys

Delete keys when they expire.

1. In the left navigation menu, tap **Content Manager**.
2. Tap the **Keys** tab.
3. Select the check box to the left of the keys.
4. Tap **Delete**.
5. To confirm the deletion, tap **Delete**.

## Collapsing or expanding columns

Expand or collapse columns to display more or less information.

- In the column heading, tap **Resize**. 

## Viewing content details

The Properties panel provides detailed information about the selected content.

1. In the left navigation menu, tap **Content Manager**.
2. Tap the **Local Content** tab.
3. Tap **Details**. 

## Loading and playing content

To play content it must be loaded first.

1. Tap and hold **Load**. 
2. Load local content or a playlist:

- To load a playlist, tap the **Playlists** tab.
- To load locally stored content, tap the **Local Content** tab.
3. Tap to select the playlist or content.
4. Tap **Load**.
5. To start playback, tap and hold **Play**. 

## Unloading content

Unload content when it has finished playing and is no longer required.

1. Stop or pause playback.
2. Tap **Unload**. 

# Managing playlists



Use the procedures in this section to manage playlists. A playlist is a list of content files and automated events that play in an order that you define.

## Creating a new playlist

A playlist is a list of content files and automated events that play in an order that you define.



To manage minor time gaps between content files, Christie recommends inserting a short period of black screen with no audio. To achieve this, you can insert a BLACK MOS clip into the playlist. BLACK MOS clips are small, silent compositions and are set in varying lengths to accommodate different projection requirements. The clips are available from content distributors.

1. In the left navigation menu, tap **Playlist Editor**.
2. In the right pane, tap **New Playlist**. 
3. In the Create New Playlist dialog, type a name for the playlist and tap **Create**.
4. Add content or an automation event to the playlist:
  - To add content to the playlist, tap the content item shown under the **Local Content** tab.
  - To add an automation event or macro to the playlist, select a content item in the playlist and then switch to the **Automation** tab. Tap the automation event or macro item to add it to the playlist.
5. In the right pane, tap **Save**. 

## Reordering playlist content

Reorder the playlist content to change the time when content plays.

1. In the left navigation menu, tap **Playlist Editor**.
2. In the upper right pane, select a playlist from the list.
3. Tap the content or a macro in the playlist.
4. To select a new position for the content or macro, tap the down arrow and select the number for the new position. For example, selecting **1** moves the item to the top of the playlist.
5. Tap **Save**. 

## Adding a time offset to a macro



An offset identifies when a macro plays in a playlist.

1. In the left navigation menu, tap **Playlist Editor**.
2. In the upper right pane, select a playlist.

3. Tap a macro in the playlist and then tap **Edit**. 
4. In Edit Automation dialog, select one of these options from the Offset Type list:
  - a) To run a macro at a time you define that is offset from the start of the macro you selected in step 3, select **After Clip Start**.
  - b) To run a macro at a time you define that is offset from the end of the content you selected in step 3, select **Before Clip End**.
  - c) To pause playback, select **Before Clip Start**. Playback does not resume until the system runs all of the input cues or macros with a time offset value of Before Clip Start. If **Before Clip Start** is not selected, playback is not paused.  
If the content contains an FFMC (First Frame Moving Credits) marker, you can also choose the **FFMC** option to set actions associated with the final credits roll.
5. Under Offset Time, adjust the time the automation occurs.
6. Tap **Update**.



## Replacing playlist content

Replace playlist content when content has been added in error, or you want to add new content to an existing playlist.

1. In the left navigation menu, tap **Playlist Editor**.
2. In the upper right pane, select a playlist from the list.
3. Tap the content in the playlist.
4. Tap **Replace Content**. 
5. In the Replace Content dialog, select the new content.
6. Tap **Replace**.
7. Tap **Save**. 



## Removing playlist content

Remove playlist content when content has been added in error, or you want to update an existing playlist.

1. In the left navigation menu, tap **Playlist Editor**.
2. In the playlist list in the upper right pane, select the playlist you want to update.
3. Tap content in the playlist.
4. Tap **Remove Content**. 
5. Tap **Save**. 

## Copying a playlist

Copy a playlist when you want to quickly create a playlist with similar content.

1. In the left navigation menu, tap **Playlist Editor**.
2. In the playlist list in the upper right pane, select the playlist you want to copy.
3. Tap the menu  and then tap **Save As**.
4. In the Save Playlist dialog, type a new name for the playlist.
5. Tap **Save**. 

## Opening an intermission playlist

Open an intermission playlist from the top level playlist.

1. In the left navigation menu, tap **Playlist Editor**.
2. Select the playlist with the intermission item to open.
3. In the right pane, tap the intermission item and then tap **Open Intermission Playlist**. 

The intermission playlist items are displayed in the right pane.

## Viewing details about playlist content

The Details dialog provides detailed information about the selected content.

1. In the left navigation menu, tap **Playlist Editor**.
2. Under the Local Content tab, to the right of the content, tap **Details**. 

## Importing a playlist

Import a playlist from another projector or computer on the network.

1. In the left navigation menu, tap **Playlist Editor**.
2. In the right pane, tap the menu  and then tap **Import Playlists**.
3. In the Import dialog, navigate to the playlist you want to import and select it.  
A filter of \*.ply is applied automatically to display available playlist files.
4. Tap **Accept**.

## Exporting a playlist

Export an existing playlist to another projector or computer on the network.

1. In the left navigation menu, tap **Playlist Editor**.
2. In the right pane, select the playlist you want to export.

3. Tap the menu  and then tap **Export Playlists**.
4. In the Export dialog, navigate to the location you want to export to.
5. Tap **Export**.

## Deleting a playlist

Delete a playlist when it is no longer required or when the content has expired.

1. In the left navigation menu, tap **Playlist Editor**.
2. In the playlist list in the upper right pane, select the playlist you want to delete.
3. Tap the menu  and then tap **Delete**.
4. To confirm the deletion, tap **Delete**.



# Working with channels

Create channels to store customized projector settings for different inputs.

## Adding a channel for HDMI input

Create a channel to store customized projector settings for input devices connected to the HDMI port.

1. In the left navigation menu, tap **Channel Setup**.
2. Tap **+ Add Channel**.
3. Complete these fields:

Field Name	Description
Name	The channel name.
Input Type	Select one of: <ul style="list-style-type: none"> <li>• HDMI Input A</li> <li>• HDMI Input B</li> <li>• HDMI 3D LR</li> <li>• Addon Card</li> <li>• IMB</li> </ul>
Data Format	The source color depth (8-10-12 bit) for the channel. If the HDMI source is 2K or greater, select one of: <ul style="list-style-type: none"> <li>• 4K 4:4:4 (RGB) 8 bits</li> <li>• 4K 4:2:2 (YCbCr) 12 bits</li> <li>• 4K 4:2:2 (YCbCr) 10 bits</li> <li>• 4K 4:2:2 (YCbCr) 8 bits</li> </ul>
Scan Type	The video scan type. The default is Auto.
3D Sync Input Mode	Specifies whether a specific frame of input data has left eye or right eye data. The default is Auto.
Color Space	The method of color decoding for the current source. The default is Unity RGB for all HDMI sources.
ILS File	The ILS file associated with the channel.
2D Lamp File	The 2D lamp file associated with the channel. Any changes made to the lamp file settings are applied to all channels that use this lamp file.
3D Lamp File	The 3D lamp file associated with the channel. Any changes made to the lamp file settings are applied to all channels that use this lamp file.
2D MCGD File	The Measured Color Gamut Data file associated with the 2D image.

Field Name	Description
3D MCGD Left Eye File	The Measured Color Gamut Data file associated with the left 3D image.
3D MCGD Right Eye File	The Measured Color Gamut Data file associated with the right 3D image.
TCGD File	The Target Color Gamut Data file associated with the channel.
Screen File	The screen type, masking, cropping, and lens settings for the channel.
Gamma File	The gamma correction required for the proper tonal range of the source material.
Clut File	Applies a 3D color cube for increased color accuracy.
3D File	The 3D settings files associated with the channel.
Source File	The resolution and aspect ratio for the channel.
HDMI EDID	The HDMI standard associated with associated with the channel.
Christie Pureformity Color™ Correction File	The color correction file associated with the channel. The default value is Bypass.

4. Tap **Save**.

## Adding a channel for IMB input

Create a channel to store customized projector settings for input devices connected to the IMB.

1. In the left navigation menu, tap **Channel Setup**.
2. Tap **+ Add Channel**.
3. Complete these fields:

Field Name	Description
Name	The channel name.
Input Type	Select IMB.
3D Sync Input Mode	<p>For third party IMBs, specifies how 3D input data is encoded. The default setting is 2D.</p> <ul style="list-style-type: none"> <li>• 2D Mode: No 3D synchronization is applied.</li> <li>• 3D Frame Interleaved: For input that contains left eye data followed by right eye data.</li> <li>• 3D Frame Interleaved Inverted: For input that contains right eye data followed by left eye data.</li> <li>• 3D White Line/Blue Line: For input that includes metadata describing the 3D encoding.</li> <li>• 3D White Line/Blue Line Inverted: For inverted input that includes metadata describing the 3D encoding.</li> <li>• 3D Line Interleaved: The left eye and right eye data are sent on alternating lines.</li> </ul> <p>3D Sync Input Mode is not required when using the Christie IMB. For GDC IMB devices, the recommended setting is 3D Line Interleaved.</p>

Field Name	Description
ILS File	The ILS file associated with the channel.
2D Lamp File	The 2D lamp file associated with the channel. Any changes made to the lamp file settings are applied to all channels that use this lamp file.
3D Lamp File	The 3D lamp file associated with the channel. Any changes made to the lamp file settings are applied to all channels that use this lamp file.
2D MCGD File	The Measured Color Gamut Data file associated with the 2D image.
3D MCGD Left Eye File	The Measured Color Gamut Data file associated with the left 3D image.
3D MCGD Right Eye File	The Measured Color Gamut Data file associated with the right 3D image.
TCGD File	The Target Color Gamut Data file associated with the channel.
Screen File	The screen type, masking, cropping, and lens settings for the channel.
Gamma File	The gamma correction required for the proper tonal range of the source material.
Clut File	Applies a 3D color cube for increased color accuracy.
3D File	The 3D settings file associated with the channel.
Source File	The resolution and aspect ratio for the channel.
Christie Pureformity Color™ Correction File	The color correction file associated with the channel. The default value is Bypass.

4. Tap **Save**.

## Editing an existing channel

Edit an existing channel when the parameters of the input device change.

1. In the left navigation menu, tap **Channel Setup**.
2. In the left pane, tap a channel.
3. Edit the channel settings.
4. Tap **Save**.



## Copying existing channel settings to a new channel

Copy a channel to create a new channel with similar settings.

1. In the left navigation menu, tap **Channel Setup**.
2. In the left pane, tap a channel.
3. Tap **Save As**.
4. Type a name for the new channel and tap **Save**.



## Changing the active channel

Use the projector touch panel to change the active channel.

1. In the right toolbar, tap **Channels**.   
The Channels window displays the available channels.
2. Tap the channel you want to activate.  
In the Channel Setup panel, a green checkmark  indicates the active channel.



## Viewing the channel list

The channel list displays all of the available channels.

- In the left navigation menu, tap **Channel Setup** or in the right toolbar, tap **Channels**.   
The available channels are displayed in the left pane. A green checkmark  indicates the active channel.

## Moving a channel up or down the channel list

If a channel is selected frequently, move it to the top of channel list to make it easier to access. If the channel is not selected frequently, move it to the bottom of the channel list.

1. In the left navigation menu, tap **Channel Setup**.
2. In the left pane, tap a channel.
3. To move the channel up or down the list, tap  or .

## Deleting a channel

Delete a channel when the settings for the input device are no longer required.



1. In the left navigation menu, tap **Channel Setup**.
2. In the left pane, tap a channel.
3. Tap **Delete**. 
4. To confirm the deletion, tap **Delete**.

# Managing color setting files

Use the procedures in this section to manage color setting files. When associated with a channel, a color setting file defines the color output for the content.

## Creating a MCGD file

Create Measured Color Gamut Data (MCGD) files to correct on-screen colors. A colorimeter is required to complete this procedure.

1. Turn on the light source and allow it to operate for 20 minutes.
2. In the left navigation menu, tap **Color Settings > MCGD File Setup**.
3. Tap **Create MCGD File**. 
4. Type a name for the MCGD file and tap **Create**.
5. If the MCGD file will be associated with a 3D channel, tap the **3D Sync** slider and select a frame rate.
6. In the red area of the chromaticity image, tap the option button to display the red test pattern.
7. Measure the red chromaticity with the colorimeter.
8. Type the red chromaticity value in the **X** field.
9. Tap **Next** and type the red chromaticity value in the **Y** field.
10. Repeat steps 7 to 9 for the green, blue, white, and black chromaticity measurements.
11. Tap **Save**. 

## Editing an existing MCGD file

Edit an existing Measured Color Gamut Data (MCGD) file when on-screen color readings change.

1. In the left navigation menu, tap **Color Settings > MCGD File Setup**.
2. In the MCGD File list, select a MCGD file.
3. Edit the MCGD file settings.
4. Tap **Save**. 

## Copying existing MCGD file settings to a new file

Copy an existing Measured Color Gamut Data (MCGD) file when you want to create a new MCGD file with similar settings.

1. In the left navigation menu, tap **Color Settings** > **MCGD File Setup**.
2. In the MCGD File list, select a MCGD file.
3. Tap **Save As.** 
4. Type a name for the MCGD file and tap **Save**.



## Deleting a MCGD file

Delete a Measured Color Gamut Data (MCGD) file when it is no longer required.

1. In the left navigation menu, tap **Color Settings** > **MCGD File Setup**.
2. In the **MCGD File** list, select a MCGD file.
3. Tap **Delete.** 
4. To confirm the deletion, tap **Delete**.

## Creating a TCGD file

Typically, Target Color Gamut Data (TCGD) file settings are defined by the content provider and are not modified. A colorimeter is required to complete this procedure.

1. Turn on the light source and allow it to operate for 20 minutes.
2. In the left navigation menu, tap **Color Settings** > **TCGD File Setup**.
3. Tap the **Create TCGD File.** 
4. Type a name for the TCGD file and tap **Create**.
5. To display test clips automatically when you select a color in the chromaticity image, select **Automatically Display Test Clips**.
6. To modify the white clipping values and improve image detail in very bright areas of the image, select **Use White Clip**.
7. Tap the option button in the red area of the chromaticity image to display the red test pattern.
8. Measure the red chromaticity with the colorimeter.
9. Type the red chromaticity values in the **Red X** and **Red Y** fields.
10. Adjust the **Gain** value to modify the color brightness.
11. Repeat steps 8 to 10 for the magenta, blue, cyan, white, yellow, and green chromaticity measurements.
12. To adjust the color of the white light in a specific area of the screen, select **White Tolerance** and a screen area.
13. Tap **Save.** 

## Editing an existing TCGD file

Edit an existing Target Color Gamut Data (TCGD) file when color readings change.

1. In the left navigation menu, tap **Color Settings > TCGD File Setup**.
2. In the **TCGD File** list, select a TCGD file.
3. Edit the TCGD file settings.
4. Tap **Save**. 

## Copying existing TCGD file settings to a new file

Copy an existing Target Color Gamut Data (TCGD) file when you want to create a new TCGD file with similar settings.

1. In the left navigation menu, tap **Color Settings > TCGD File Setup**.
2. In the TCGD File list, select a TCGD file.
3. Tap **Save As**. 
4. Type a name for the TCGD file and tap **Save**.

## Deleting a TCGD file

Delete a Target Color Gamut Data (TCGD) file when it is no longer required.

1. In the left navigation menu, tap **Color Settings > TCGD File Setup**.
2. In the TCGD File list, select a TCGD file.
3. Tap **Delete**. 
4. To confirm the deletion, tap **Delete**.

# Adjusting the image size and position

Learn how to enable and modify projector image settings.



## Activating the Intelligent Lens System

Activate the Intelligent Lens System (ILS) to automatically adjust the position of the lens.

1. In the left navigation menu, tap **Service Setup** > **Preferences**.
2. Tap **Lens/ILS**.
3. In the right pane, tap the **ILS Installed** slider.  
The color of the slider changes to green to indicate the ILS is active.

## Creating a new ILS file

Create an Intelligent Lens System (ILS) file to set the X, Y, zoom, and focus positions of the lens.

1. In the left navigation menu, tap **Image Settings** > **ILS File Setup**.
2. Tap **Create ILS File**. 
3. Type a name for the ILS file and tap **Create**.
4. In the Lens position area, tap the forward, backward, left, or right arrow icons to move the position of the image on the screen.
5. In the **Focus** area, tap **Up** (^) or **Down** (v) to increase or decrease image focus.
6. In the **Zoom** area, tap **Up** (^) or **Down** (v) to increase or decrease image zoom.
7. Tap **Save**. 

## Calibrating the ILS automatically

Use the Auto Calibrate feature of the Intelligent Lens System (ILS) to find and compensate for motor backlash, and to determine the movement range for the currently installed lens.

1. In the left navigation menu, tap **Image Settings** > **ILS File Setup**.
2. Tap **Create**. 
3. Type a name for the ILS file and tap **Create**.
4. Tap **Auto Calibrate**.
5. Tap **Continue**.



## Editing ILS file settings

Edit Intelligent Lens System (ILS) file settings when content requirements change.

1. In the left navigation menu, tap **Image Settings > ILS File Setup**.
2. In the ILS File list, select an ILS file.
3. Modify the ILS file settings.
4. Tap **Save**. 

## Copying existing ILS file settings

To duplicate Intelligent Lens System (ILS) file settings quickly, copy the settings of an existing file to a new ILS file.

1. In the left navigation menu, tap **Image Settings > ILS File Setup**.
2. In the ILS File list, select the ILS file you want to copy.
3. Tap **Save As**. 
4. Type a name for the ILS file and tap **Save**.

## Deleting an ILS file

Delete an Intelligent Lens System (ILS) file when it is no longer required.

1. In the left navigation menu, tap **Image Settings > ILS File Setup**.
2. In the ILS File list, select the ILS file you want to delete.
3. Tap **Delete**. 
4. To confirm the deletion, tap **Delete**.



## Resetting the lens

Use the Reset Lens feature to have the Intelligent Lens System (ILS) find the home position flags that allow the ILS to compensate for drift over time, or move to its proper position after it has been manually adjusted.

1. In the left navigation menu, tap **Image Settings > ILS File Setup**.
2. In the ILS File list, select an ILS file.
3. Tap **Reset Lens**.
4. Tap **Continue**.

## Creating a source file

Create source files to store resolution, offset, and aspect ratio settings for input devices. When the Auto Square Pixels file is selected, the incoming video format is automatically detected.

1. In the left navigation menu, tap **Image Settings** > **Source File Setup**.
2. Tap **Create Source File**. 
3. Type a name for the source file and tap **Create**.
4. In the Source Media Resolution area, adjust the width and height of the source media.
5. Select an aspect ratio or type a custom aspect ratio for the source media.
6. In the Position area, adjust the horizontal and vertical position of the source media.
7. Tap **Save**. 

## Editing source file settings

Edit source file settings when the settings of the input device change.

1. In the left navigation menu, tap **Image Settings** > **Source File Setup**.
2. In the Source File list, select a source file.
3. Modify the source file settings.
4. Tap **Save**. 

## Copying existing source file settings to a new source file

To duplicate existing source file settings quickly, copy the settings of an existing file to a new source file.

1. In the left navigation menu, tap **Image Settings** > **Source File Setup**.
2. In the Source File list, select the source file you want to copy.
3. Tap **Save As**. 
4. Type a name for the source file and tap **Save**.



## Deleting a source file

Delete a source file when it is no longer required.

1. In the left navigation menu, tap **Images Settings** > **Source File Setup**.
2. In the Source File list, select the source file you want to delete.
3. Tap **Delete**. 
4. To confirm the deletion, tap **Delete**.

## Creating a screen file

Use screen files to define the size of the display panel and image cropping. You can assign the same screen file to multiple input devices.

1. In the left navigation menu, tap **Image Settings** > **Screen File Setup**.
2. Tap **Create Screen File**. 
3. Type a name for the screen file and tap **Create**.
4. To crop the image in a specific location, tap one of the screen icons.
5. To adjust the amount of cropping on the x or y axis, move the slider up or down.
6. To display all image data and maintain the aspect ratio, tap the **Letterbox** slider. The color of the slider changes to green to indicate it is active.
7. If required, adjust the **Anamorphic Lens Factor** value to match the lens installed.
8. Tap **Save**. 

## Editing screen file settings

Edit screen file settings when the image parameters change.

1. In the left navigation menu, tap **Image Settings** > **Screen File Setup**.
2. In the Screen File list, select a screen file.
3. Modify the screen file settings.
4. Tap **Save**. 

## Copying existing screen file settings to a new screen

To duplicate screen file settings quickly, copy the settings of an existing file to a new screen file.

1. Tap **Image Settings** > **Screen File Setup**.
2. In the Screen File list, select the screen file you want to copy.
3. Tap **Save As**. 
4. Type a name for the source file and tap **Save**.

## Deleting a screen file

Delete a screen file when it is no longer required.

1. In the left navigation menu, tap **Image Settings** > **Screen File Setup**.
2. In the Screen File list, select the screen file you want to delete.
3. Tap **Delete**. 

4. To confirm the deletion, tap **Delete**.

## Performing digital convergence

Perform digital convergence to improve the quality of the on-screen image.

1. In the left navigation menu, tap **Image Settings > Digital Convergence**.
2. Tap the up, down, left, or right arrows to adjust the position of the red, green, or blue digital micromirrors (DMDs).

## Resetting digital convergence to the default settings

Reset digital convergence to the default settings when image parameters change.

1. In the left navigation menu, tap **Image Settings > Digital Convergence**.
2. Tap **Reset Defaults**.

# Adjusting the image

Adjust the projector image. Christie recommends warming the lens before completing these procedures as focus may change as the lens warms.

## Correcting keystone effect

Learn how to adjust the image to correct keystone effect.

Keystone effect occurs when you project an image onto the screen at an angle. As a result, the image appears distorted and resembles a trapezoid.

If the image suffers from slight keystone effect, it can be corrected with electronic cropping.

If the keystone effect is severe, you can unevenly adjust the feet to compensate for projector tilt. It is recommended that you use lens offset to align the center of the image to the center of the screen before you correct the keystone effect.

If one side of the image is longer than another, adjust the tilt and level of the projector.



When making the adjustments, set the light source to minimum power.

Horizontal keystone	Vertical keystone
Projector skewed horizontally to the screen	Projector tilted vertically to the screen

## Correcting dual projector horizontal keystone

Learn how to correct horizontal keystone.

1. On both projectors, turn the light source on and open the douser.
2. Align the dual projector images.

3. On the top projector, display the DC2K Framing Green test pattern.
4. On the bottom projector, display the DC2K Framing Red test pattern.
5. Verify that both projectors are level.
6. Identify which projector has the horizontal keystone issue. In this example, the top projector has the horizontal keystone issue.



If both projectors have the horizontal keystone issue, correcting the image on the bottom projector should resolve the issue on both projectors.

7. On the top projector, remove the locking brackets from the projector feet.
8. Move the rear of the top projector to the right or left until the vertical lines are as equally offset as possible.

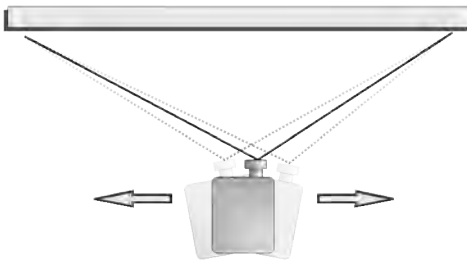

9. Reinstall the locking brackets removed in step 7.
10. On the touch panel, tap the **Lens Adjust** icon on the main screen and then tap the **left** or **right arrow** icons in the Offset area to bring the vertical lines closer together.
11. If required, on each projector, tap the **Lens Adjust** icon and then tap the **left** and **right focus** icons in the Focus area until both images are the same size and focused.

## Correcting dual projector vertical keystone

Learn how to correct vertical keystone.

1. On both projectors, turn the light source on and open the douser.
2. Align the dual projector images.
3. On the top projector, display the DC2K Framing Green test pattern.
4. On the bottom projector, display the DC2K Framing Red test pattern.
5. Identify which projector has the vertical keystone issue. In this example, the top projector has the vertical keystone issue.

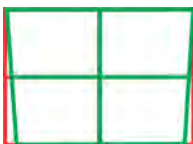

If both projectors have the horizontal keystone issue, correcting the image on the bottom projector should resolve the issue on both projectors.

6. On the top projector, remove the locking brackets from the projector feet.
7. Raise or lower the rear feet of the top projector until the projected images of both projectors are vertically aligned. The feet should be raised or lowered an equal amount.
8. Reinstall the locking brackets removed in step 6.
9. On the touch panel, tap the **Lens Adjust** icon on the main screen and then tap the **forward** or **backward arrows** in the Offset area to bring the horizontal lines closer together.
10. If required, on each projector, tap the **Lens Adjust** icon and then tap the **left focus** and **right focus** icons in the Focus area until both images are the same size and focused.

## Correcting vignetting

An image that is brighter at the center than it is at the sides needs vignetting correction.

If your image suffers from vignetting, the lens has reached the end of its offset travel range. If your installation does not allow the image to be centered with the center of the screen, move the entire projector in the direction of lens travel.

## Adjusting vertical boresight

Perform a top and bottom boresight adjustment to fix image focus issues that cannot be corrected by aligning the projector to the screen and focusing the lens.



**Caution!** If not avoided, the following could result in minor or moderate injury.

- This procedure must be performed by Christie qualified technicians.

Ensure that the projector is perpendicular to the screen before adjusting boresight.

We recommend that you complete a top and bottom boresight adjustment before adjusting the horizontal boresight.

A boresight adjustment should only be made when the image cannot be focused uniformly on the screen by aligning the projector to the screen and focusing the lens. When adjusting boresight, you must maintain the boresight distance from the lens to the prism plane set by Christie. For example, when you move the top screw outward, turn the bottom two boresight screws to maintain the overall distance.

Ensure that the boresight lockdown screws are adequately tightened. Not adequately tightening the boresight screws can result in excessive onscreen image vibration. After adjusting boresight, evaluate the onscreen image vibration and re-adjust if needed.

1. Remove the lens surround.
2. Display the DC2K Boresight test pattern.
3. Loosen the set screw (B).

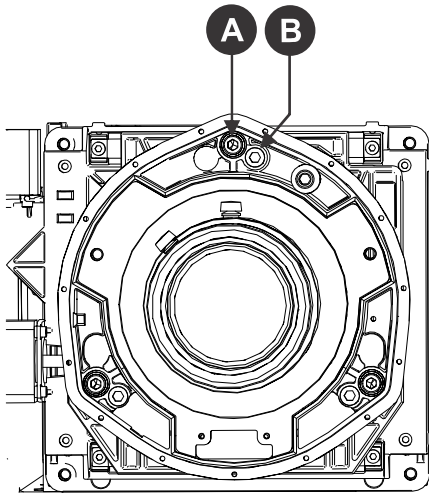

A	Cap screw: Adjusts top and bottom boresight
B	Set screw: Locks or unlocks the cap screw

4. Turn the vertical cap screw (A) 1/8 of a turn counter-clockwise.  
Only adjust vertical boresight 1/8 of a turn or less at one time to maintain optimal lens performance (factory setup of absolute lens distance to the prism). It is critical that you count each turn of the cap screws to ensure accurate adjustment.
5. Adjust both left and right horizontal adjusters by half the number of turns, in the opposite direction of the vertical adjust.  
For example, if the vertical adjust cap screw was turned 1/8 of a turn, the left and right horizontal cap screws should be turned 1/16 of a turn in the opposite direction.
6. Check the screen each time an adjustment is made. If the quality of the projected image has degraded, turn the vertical adjust cap screw 1/8 of turn clockwise. Ensure the left and right horizontal adjusters are adjusted equally in the opposite direction to correct axial focus. The 1/8 of a turn is a suggestion only and can be less if needed; however, it should never be exceeded. Always compensate both left and right horizontal adjustments according to the vertical adjustment.
7. Check the image after each adjustment. Continue to make adjustments until both top and bottom are equally sharp. To make sure the lens is in the same relative position, adjust the left and right horizontal adjusters in the opposite direction at the same time.
8. When the top and bottom of the image are equally in focus lock the set screw to hold it in position. Recheck the image.
9. If additional adjustment is required, try adjusting horizontal boresight.
10. Replace the lens surround.

## Adjusting horizontal boresight

Perform a horizontal boresight adjustment when the image cannot be focused uniformly on the screen by aligning the projector to the screen and focusing the lens.



**Caution!** If not avoided, the following could result in minor or moderate injury.

- This procedure must be performed by Christie qualified technicians.



Typically, horizontal boresight does not require adjustment. It should only be adjusted if a large horizontal angular offset to the screen is required.

When adjusting boresight, you must maintain the boresight distance from the lens to the prism plane set by Christie. For example, when you move the top screw outward, turn the bottom two boresight screws to maintain the overall distance.

Only adjust horizontal boresight 1/8 of a turn or less at one time to maintain optimal lens performance (factory setup of absolute lens distance to the prism). It is critical that you count each turn of the cap screws to ensure accurate adjustment.

Ensure that the boresight lockdown screws are adequately tightened. Not adequately tightening the boresight screws can result in excessive onscreen image vibration. After adjusting boresight, evaluate the onscreen image vibration and re-adjust if needed.

1. Remove the lens surround.
2. Display the DC2K Boresight test pattern.
3. Loosen the right boresight set screw (B).

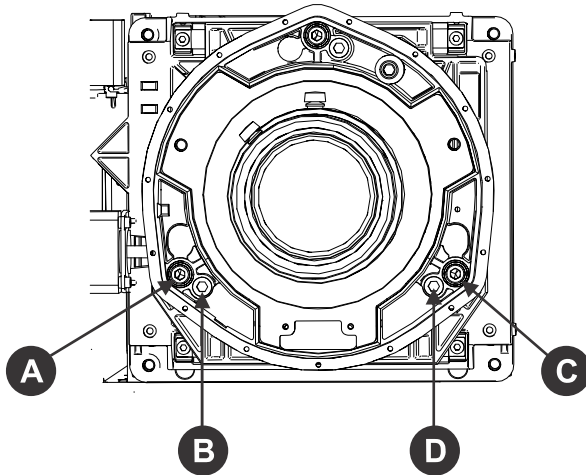

A	Right Boresight Cap Screw
B	Right Boresight Set Screw
C	Left Boresight Cap Screw
D	Left Boresight Set Screw

4. Turn the right boresight cap screw (A) 1/16 of a turn clockwise.
5. Adjust the left boresight cap screw (C) equally in the opposite direction.
6. If the quality of the projected image has not improved, turn the right boresight cap screw 1/16 of turn counter-clockwise. Make sure the left adjuster is adjusted equally in the opposite direction.
7. Check the screen each time an adjustment is made. The right-side adjustments affect the top right and bottom left points on the screen. Once both cross hairs are in focus, lock the set screw for right boresight.
8. Repeat steps 5 to 7 for the left side.
9. Verify that each corner of the screen is equally in focus.  
If this is not the case, repeat vertical boresight.

## Adjusting digital micromirror device convergence

A digital micromirror device (DMD) convergence problem occurs when one or more projected colors (red, green, blue) appears misaligned when examined with a convergence test pattern.

Normally, the three colors should overlap precisely to form pure white lines throughout the image and one or more poorly converged individual colors may appear adjacent to some or all of the lines.

Contact your Christie accredited service technician to correct DMD convergence issues.

## Adjusting the fold mirror

Learn how to align the fold mirror with the optical system to correct an image with missing or shadowy corners or edges.

1. Remove the top cover.
2. Display the RGB-12bit-Full Screen White test pattern.
3. Insert a hex driver in the first set screw (A) and a hex driver in the first cap screw (B).

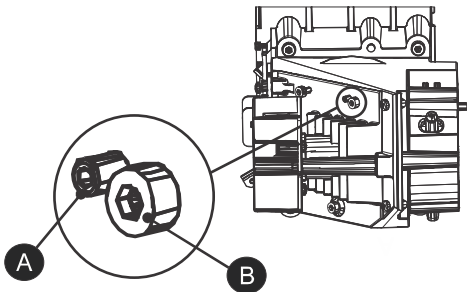

4. Equally turn the set screw (A) and cap screw (B) in opposite directions until the black corner is removed.
5. If the black corner remains, insert a hex driver in the second set screw (C) and a hex driver in the second cap screw (D).

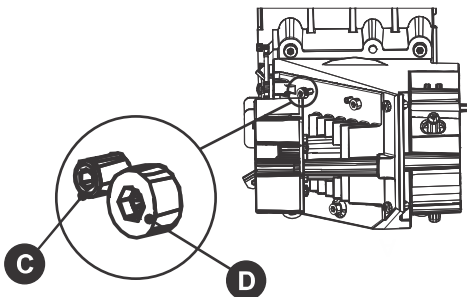

6. Equally turn the set screw (C) and cap screw (D) in opposite directions until the black corner is removed.
7. Replace the top cover.

## Calibrating the color

Learn how to create Measured Color Gamut Data (MCGD) files to correct on-screen colors. Using a colorimeter, measure the colors displayed on the screen from the center of the audience viewing location.

## Masking the screen edges

Conceal the unused edges of a screen with top or side masking.

Typically, you install top and side masking to allow a greater range of adjustment.

1. To create top masking:
  - a) Install movable flat black panels or curtains along the top edge of the screen.
  - b) Raise the curtain for flat images or lower the curtain for scope images.

**Top masking theater (1.85 screens)**

A	1.85 image
B	2.39 image
C	Masking moved up
D	Top masking to hide screen top

2. To create side masking:
  - a) Install movable flat black panels or curtains along each side of the screen.
  - b) Close the curtain for flat images or open the curtain and zoom for scope images.

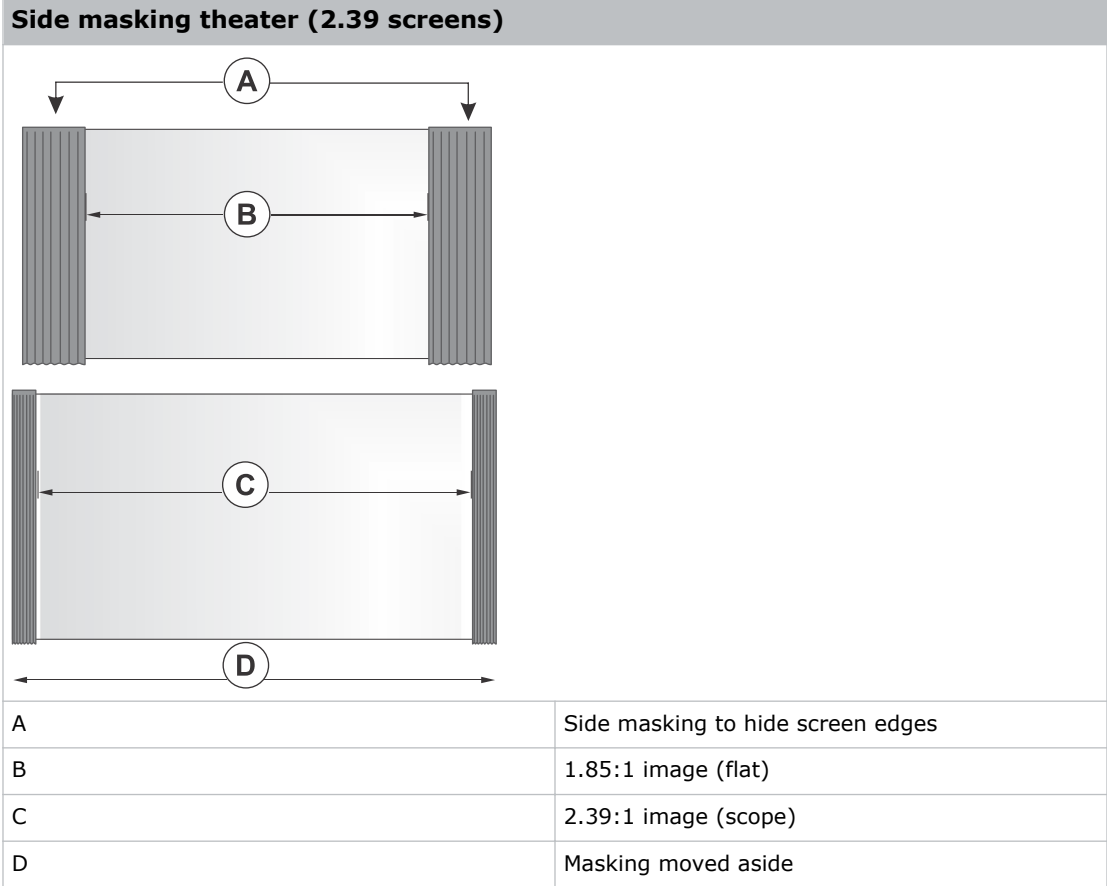

# Test patterns

Use the projector and the available test patterns to assist with configuration of the projector and to diagnose any issues that may occur.

## Displaying a test pattern

Display a test pattern to refine and adjust the projected image or diagnose and correct image issues.

1. In the right toolbar, tap **Test Patterns**. 
2. Tap **Full Screen** or **Uncorrected Colors**.
3. Tap a test pattern.  
When a test pattern is active, a blue bar appears below the test pattern icon in the right pane.

## Turning off a test pattern

Turn off a test pattern when adjustment of the projected image is complete.

1. In the right toolbar, tap **Test Patterns**. 
2. Tap **Test Pattern Off**.

## Importing a test pattern

Import custom test patterns to meet the specific requirements of your viewing environment.

1. In the right toolbar, tap **Test Patterns**. 
2. In the upper right corner, tap **Edit**.
3. Tap **Import**.
4. Browse to the location of the test pattern file.
5. Tap the test pattern file.
6. Tap **Accept**.
7. In the upper right corner, tap **Done**.

## Deleting a test pattern

Delete a test pattern that is no longer required. A test pattern with **RGB** in the name cannot be deleted.

1. In the right toolbar, tap **Test Patterns**. 



2. In the upper right corner, tap **Edit**.
3. Tap a test pattern.
4. Tap **Delete**.
5. To confirm the deletion, tap **Delete**.
6. In the upper right corner, tap **Done**.

# Working with the scheduler

Use the scheduler to schedule playlists and automated events to play automatically on a specific date at a specific time.

## Scheduling a playlist, content, or automation

Schedule a playlist, content, or automation to run automatically on a specific date and time.

1. In the left navigation menu, tap **Scheduler**.
2. To enable scheduled events, tap the **Auto Playback is OFF** slider. The color of the slider changes to green to indicate it is active.
3. To select a date for the scheduled event, tap **Calendar**. 
4. Tap a square below the date and next to the time that you want the event to run.
5. Tap **+ New Event**.
6. Tap **Playlist**, **Content**, or **Automation**.
7. Tap to select a playlist, content, or automation item.
8. Select the start time.
9. Select the start date.
10. To repeat the event daily, weekly, or monthly:
  - a) Tap the **Recurrence** slider.
  - b) Select the frequency of the recurrence. The options are daily, weekly, or monthly.
  - c) Select the days or months that you want the playlist, content, or automation event to play.
  - d) To select an end date for the schedule, tap **Calendar**. 
11. To prevent the scheduled event from being overwritten, tap the **Lock Event** slider. Locked events cannot be copied or overwritten by pasted events.
12. Tap **Create Event**.

## Editing a scheduled event

Edit a scheduled event to modify the run time and date.

1. In the left navigation menu, tap **Scheduler**.
2. In the calendar view, tap the scheduled event.
3. Tap **Edit**.

4. Edit the scheduled event settings.
5. Tap **Update Event**.

## Copying and pasting an existing scheduled event

To run a scheduled event at a different date and time, copy and paste it.

1. In the left navigation menu, tap **Scheduler**.
2. In the calendar view, tap the scheduled event.
3. Tap **Copy**.
4. Tap a square below the date and next to the time that you want the event to run.
5. Tap **Paste**.
6. Adjust the any settings for the scheduled event.
7. Tap **Paste Event**.

## Copying and pasting scheduled events for an entire day

To run an existing full day of scheduled events on a different date, copy and paste the entire day of scheduled events.

1. In the left navigation menu, tap **Scheduler**.
2. At the top of the calendar, tap the day with the events you want to copy.
3. Tap **Copy**.
4. At the top of the calendar, tap the new target day.
5. Tap **Paste**.

## Cutting and pasting a scheduled event

To move an existing scheduled event to a different date and time, cut and paste it.

1. In the left navigation menu, tap **Scheduler**.
2. In the calendar view, tap the scheduled event.
3. Tap **Cut**.
4. Tap the new date in the calendar.
5. Tap **Paste**.
6. Adjust the settings for the scheduled event.
7. Tap **Paste Event**.



## Deleting a scheduled event

Delete an individual schedule event when it is no longer required.

1. In the left navigation menu, tap **Scheduler**.
2. In the calendar view, tap the scheduled event.
3. Tap **Delete**.
4. To confirm the deletion, tap **Delete**.

## Deleting scheduled events for an entire day

Delete the scheduled events for an entire day when they are no longer required.

1. In the left navigation menu, tap **Scheduler**.
2. At the top of the calendar, tap the target day.
3. Tap **Clear Day**.
4. To confirm the change, tap **Clear Day**.

## Changing the day of the week the scheduler starts

Change the start day of the scheduler to match the schedule of the theater.

1. In the left navigation menu, tap **Service Setup > Preferences**.
2. Tap **General**.
3. In the Scheduler area, select the day of the week to start the scheduler.

## Turning the scheduler off

Turn the scheduler off when you do not want scheduled events to run automatically on a specific date and time.

1. In the left navigation menu, tap **Scheduler**.
2. To disable scheduled events, tap the **Scheduler is on** slider.  
The color of the slider changes to gray to indicate it is inactive.

# Managing storage devices

Learn how to add, edit, and remove external storage devices and ingest sources.

## Adding a new storage device

Add a new storage device to store and play content.

1. In the left navigation menu, tap **Service Setup** > **Storage Device Setup**.
2. Tap **+ New Storage Device**.
3. Complete these fields:
  - Name—The name of the storage device.
  - IP Address—The IP address of the storage device.
  - Username—The user account or ID (if required to connect to the storage device).
  - Password—The password for the user account (if required to connect to the storage device).
  - Share Folder—The folder where content is stored.
  - Drive Type—Select Content Drive or Ingest Drive.
4. To make the content drive the primary storage drive, tap the **Set as Primary Drive** slider. The color of the slider changes to green to indicate it is active.
5. To test the connection to the storage device, tap **Test Connection**.
6. Tap **Save**.

## Editing storage device settings

Edit storage device settings when device or communication settings change.

1. In the left navigation menu, tap **Service Setup** > **Storage Device Setup**.
2. Tap a storage device in the left pane.
3. Edit the settings in the right pane.
4. Tap **Save**.

## Setting a storage device as a primary drive

A primary drive is the device that is the primary source of content.

1. In the left navigation menu, tap **Service Setup** > **Storage Device Setup**.

2. Tap a storage device in the left pane.
3. To make the new storage device the primary storage drive, tap the **Set as Primary Drive** slider.  
The color of the slider changes to green to indicate it is active.
4. Tap **Save**.

## Deleting a storage device

Delete a storage device when it is no longer required.

1. In the left navigation menu, tap **Service Setup** > **Storage Device Setup**.
2. In the left pane, tap a storage device.
3. Tap **Delete**. 
4. To confirm the deletion, tap **Delete**.

## Adding a remote ingest source

Add a remote ingest source to uploaded content from a remote storage device.

1. In the left navigation menu, tap **Service Setup** > **Remote Ingest Setup**.
2. Tap **+ New Ingest Source**.
3. In the Name field, type a name for the ingest source.
4. In the IP Address field, type an IP address for the ingest source.
5. Tap **Add**.
6. In the right pane, enter a user name and a password if required for the ingest source.
7. Tap the **Type** list and select the device type.
8. To test the connection to the ingest source, tap **Test Connection**.
9. To save the configuration, tap **Save**.

## Editing remote ingest source settings

Edit the settings of remote ingest sources when device or communication settings change.

1. In the left navigation menu, tap **Service Setup** > **Remote Ingest Setup**.
2. In the left pane, tap a remote ingest source.
3. Edit the settings displayed in the right pane.
4. Tap **Save**.

## Deleting a remote ingest source

Delete a remote ingest source when it is no longer required.

1. In the left navigation menu, tap **Service Setup** > **Remote Ingest Setup**.



2. In the left pane, tap a remote ingest source.
3. Tap **Delete**. 
4. To confirm the deletion, tap **Delete**.

# Managing projector setting files

Projector setting files store projector settings. When a projector setting file is associated with a channel, the projector settings are automatically adjusted to match the requirements of the content.

## Creating a 3D file

Create a 3D file if you are playing 3D content on a single projector or using active 3D with multiple projectors.

1. In the left navigation menu, tap **Image Settings > 3D File Setup**.
2. Tap **Create 3D File**. 
3. Type a name for the 3D file and tap **Create**.
4. In the General Settings area, complete these fields:
  - **3D Delay**—Creates a delay to allow the 3D system to synchronize the output and reduce on screen artifacts.
  - **Invert 3D Sync Polarity**—Reverses 3D stereo sync output (left eye = right eye and right eye = left eye).
5. In the Frame Rate Settings area, complete these fields:
  - **Dark Time**—Creates a blank time interval in microseconds ( $\mu\text{s}$ ) between left and right frames to allow for LCD shutter glasses, Z screen, or rotating 3D wheel to synchronize the output.
  - **Output Delay** —The time interval in microseconds ( $\mu\text{s}$ ) when an image is not displayed. Offset 3D stereo sync output in relation to the dark time interval. A positive offset adds a delay and a negative offset starts playback early.
  - **Phase Delay**—The degree of reference between the left and right sync output.
  - **Multiplier**—Sets the number of frames to display per number of frames that form one complete image. You can increase the display frame rate to reduce flicker from your source.
6. Tap **Save**. 

## Editing an existing 3D file

Edit an existing 3D file to match the settings of the 3D hardware.

1. In the left navigation menu, tap **Image Settings > 3D File Setup**.
2. In the 3D File list, select a file.

3. Edit the 3D file settings.
4. Tap **Save**. 

## Copying a 3D file

Copy an existing 3D file to create a new 3D file with similar settings.

1. In the left navigation menu, tap **Image Settings > 3D File Setup**.
2. In the 3D File list, select a file.
3. Tap **Save As**. 
4. Type a new name for the file.
5. Tap **Save**.

## Deleting a 3D file

Delete a 3D file when it is no longer required.

1. In the left navigation menu, tap **Image Settings > 3D File Setup**.
2. In the 3D File list, select a file.
3. Tap **Delete**. 
4. To confirm the deletion, tap **Delete**.

# Managing audio settings

Learn how to enable and modify projector audio settings.

## Setting the global audio delay

The global audio delay setting increases or decreases the audio delay.

1. In the left navigation menu, tap **Service Setup** > **Audio Setup**.
2. On the **Global Settings** tab, in the Global Audio Delay area, select one of these options:
  - To increase the audio delay, tap **Up**. ^
  - To decrease the audio delay, tap **Down**. v

## Setting the audio output rate

Adjust the audio output rate to match the output of the audio device.

1. In the left navigation menu, tap **Service Setup** > **Audio Setup**.
2. On the **Global Settings** tab, in the Audio Output Rate area, select one of these options:
  - Automatic
  - 48 kHz
  - 96 kHz

## Mapping channels

Use the Channel Mapping tab to map the Digital Cinema Package (DCP) audio channels to the AES outputs. Interop is the most common audio setting.

1. In the left navigation menu, tap **Service Setup** > **Audio Setup**.
2. Tap the **Channel Mapping** tab.
3. In the Channel Format list, select an audio format.  
The selection in the Channel Format list does not determine the audio format. The content determines the audio format. For example, if you select SMPTE 7.1 DS and Interop is specified in the content, the Interop audio settings are applied when the content plays.
4. Select the channel that matches the speaker specified in the *Interop Channel Mapping Guide*.
5. For any speakers not being used, select **Not Used**.
6. To test the channel mapping setting, tap **Test**.

## Enabling Dolby Atmos

To play content with Dolby Atmos audio, enable Dolby Atmos.

1. Tap **Service Setup > Audio Setup**.
2. Tap the **Dolby Atmos Configuration** tab.
3. Tap the **Enable Dolby Atmos** slider.  
The color of the slider changes to green to indicate it is active.
4. In the Control IP field, type the control IP address.
5. In the Input IP field, type the input IP address.
6. To test Dolby Atmos connectivity, tap **Test Connection**.
7. Tap **Save**.

## Editing Dolby Atmos settings

Edit Dolby Atmos settings when device settings change.

1. Tap **Service Setup > Audio Setup**.
2. Tap the **Dolby Atmos Configuration** tab.
3. Edit the Control IP and Input IP fields.
4. To test Dolby Atmos connectivity, tap **Test Connection**.
5. Tap **Save**.

## Disabling Dolby Atmos

Disable Dolby Atmos when Dolby Atmos audio playback is no longer required.

1. Tap **Service Setup > Audio Setup**.
2. Tap the **Dolby Atmos Configuration** tab.
3. Tap the **Enable Dolby Atmos** slider.  
The color of the slider changes to gray to indicate it is inactive.
4. Tap **Save**.



# Setting up multiple projectors

Learn how to add, modify, and remove master and slave projectors.

## Enabling multiple projectors

Enable multiple projectors to display 3D or HDR content.

1. In the left navigation menu, tap **Service Setup** > **Multi-Projector Setup**.
2. Tap the **Multi-Projector Control** slider.  
The color of the slider changes to green to indicate it is active.
3. Tap the **Active 3D Glasses** slider if you are using active 3D glasses and want to send left and right images to multiple projectors.  
If you select this option, you cannot change the eye selection setting.
4. In the Master Eye Selection list, select **Right** or **Left** for the master projector.  
This option is not available when you select **Active 3D Glasses**.

## Adding a slave projector

Add a slave projector to display 3D or HDR content.

1. In the left navigation menu, tap **Service Setup** > **Multi-Projector Setup**.
2. Tap **New Slave Projector**.  
This option is available only when the **Multi-Projector Control** slider is selected.
3. Type a name and an IP address for the projector.
4. Tap **Add**.
5. In the Eye Selection column, select **Right** or **Left**.

## Enabling content synchronization

Complete this procedure on the master projector.

Content synchronization is supported for Christie network attached storage (NAS) devices only. To synchronize content, you must also enable the **Multi-Projector Control** option on the master projector.



To enable content synchronization, you must set up a network connection between NAS devices. For detailed information, see the documentation provided with the Christie NAS.

1. On the master projector touch panel, tap **Service Setup > Multi-Projector Setup**.
2. Under Master Projector Settings, tap **Multi-Projector Sync of Content**.  
The color of the slider turns to green to indicate content synchronization is active. When enabled, ingested content on the master projector is synchronized to all slave projectors automatically.

## Disabling multiple projectors

Disable multi-projector settings when the second projector is not required to display content.

1. In the left navigation menu, tap **Service Setup > Multi-Projector Setup**.
2. Tap the **Multi-Projector Control** slider.  
The color of the slider changes to gray to indicate it is inactive.

## Disabling a slave projector

Disable a slave projector when it is no longer required or when it is replaced by another projector.

1. In the left navigation menu, tap **Service Setup > Multi-Projector Setup**.
2. Tap the slider in the **Enabled** column of the slave projector you want to disable.  
The color of the slider changes to gray to indicate it is inactive.

## Deleting a slave projector

Delete a projector from a multi-projector configuration when it is no longer required or when it is replaced by another projector.

1. In the left navigation menu, tap **Service Setup > Multi-Projector Setup**.
2. In the Delete column of the slave projector you want to delete, tap **Delete**. 
3. To confirm the deletion, tap **Delete**.

# Automation

You use automation to control playback, the projector, and external devices. This section provides instructions for managing and defining:

- **Macros** - A macro is a list of actions that you define. For example, opening the curtains or turning on the house lights at the end of playback. A macro can be activated by a global trigger, or it can be added to a playlist.
- **Device Input Triggers** - Input cues wait for events such as a general purpose input (GPI) state change or an Ethernet message received on TPC port 5111. An input cue in a playlist delays playback until an event occurs.
- **Global Triggers** - A global trigger combines an input cue with a macro. When the predefined event for the input cue occurs, the output macro is triggered. For example, a fire alarm input signal could cause playback to stop and the house lights to come on. A global trigger is always active and is not dependent on specific playlist definitions.

## Available macro actions

These are the macro actions that are available to control automated events:

Action Item	Available Actions	Description
Automation	Set Global	Allows you to set a global variable that can be used in automation scripting (intended for advanced scripting by Christie)
	Print	Generates a projector log entry when an automation macro runs
	Get Global	Allows the automation script to read the value of a global variable (intended for advanced scripting by Christie)
	Set GPO	Sets the specified GPO pin to high or low
	Pulse GPO	Pulses the specified GPO pin
	Get GPI	Allows an automation script to read the GPI state (intended for advanced scripting by Christie)
	Delay	Delays macro execution
	Wait On GPI	Pauses the automation script and waits for the specified GPI event to enter the specified state
Playback	Pause	Pauses playback
	Stop	Stops playback
	Play	Starts or resumes playback
	Toggle	Pauses playback if content is playing OR resumes playback if content is paused

Action Item	Available Actions	Description
	Disable Subtitle	Disables subtitles for the current content and onward
	Jog	Moves content forward by the time specified
Projector	Douser Open	Opens the douser
	Douser Close	Closes the douser
	Light On	Turns the light on
	Light Off	Turns the light off
	Standby	Puts the projector in standby mode
	Channel	Selects a specific projector channel
	Revert Warp File	Reverts a modified warp file to the default settings
	Full Power	Places the projector in full power mode (douser open, light on)
	Wait	Delays the execution of a macro

## Christie ACT actions

These are the available built-in commands for the Christie ACT:

Command	Description
Buzzer	Activates the buzzer for the specified time (in milliseconds)
Button	Simulates pressing or holding the ACT button
Pulse Relay	Sends a pulse to a specific relay
Open Relay	Opens a specific relay
Close Relay	Closes a specific relay
Pulse GPO	Sends a pulse to a specific GPO pin
Set All GPOs	Sets the values for all GPO pins
Run Script	Runs a script on the Christie ACT
Flash LED	Causes a specific LED to flash
Set All LEDs	Sets values for all of the LEDs

## JNIOR actions

These are the available built-in commands for JNIOR devices:

Command	Description
Open Relay	Opens a specific JNIOR relay
Close Relay	Closes a specific JNIOR relay

Command	Description
Pulse Relay	Sends a pulse to a specific JNIOR relay for the specified time (in milliseconds)
Execute Macro	Executes a JNIOR macro

You can create macros on the JNIOR device and call them using the `Execute Macro` command. Make sure you use `\0D` for a carriage return and `\0A` for a line feed.

To create and run macros on the JNIOR, use the JNIOR Support Tool to enable and configure the Cinema.JNIOR application. It is recommended that you install Cinema.JNIOR version 2.22.1115.1501 or later. For additional information, see INTEG Process Group ([www.integpg.com](http://www.integpg.com)). Port 9200 is the default Ethernet port for sending automation commands to the JNIOR.

## Dolby Cinema processor actions

These are the available built-in commands for Dolby CP650, CP750, and CP850 devices:

Command	Description
Mute On/Mute Off	Enables or disables muting
Set Format (CP650 only)	Selects the format
Set Fader Level	Sets the fader level
Send Message (CP850 only)	Sends the specified message

If you need to control additional functions and a built-in command is not available, send a command string in a macro. For example, send this command to enable surround boost on the Dolby CP750:  
`cp750.sys.surround_boost 1\0D`

Make sure that you include a carriage return (`\0D`) at the end of each command. For more information about controlling other features with serial commands, see the Dolby CP750 documentation.

The default Ethernet port for sending automation commands to the Dolby CP650 is port 61412. For Dolby CP750 and CP850, the default Ethernet port is port 61408.



## SKA-3D actions

These are the available built-in commands for SKA-3D devices:

Command	Description
Set Audio Input Channel	Sets the audio input channel
Mute On/Mute Off	Enables or disables muting
Set Master Volume	Sets the master volume for the system
Set Video Input Channel	Sets the video input channel
Active Trigger Input	Controls eight SKA-3D presets To use this command, a trigger input must be associated with each of the SKA-3D presets

## Creating a macro

Create a macro to make the projector perform a specific list of actions.

1. In the left navigation menu, tap **Automation > Macro Editor**.
2. In the right pane, tap **Create New Macro**. 
3. Type a name for the macro.
4. Select the macro type.
5. Tap **Create**.
6. Add an action item to the macro:
  - a) In the left pane, expand the My Auditorium list.
  - b) Select the type of device the macro will apply to.
  - c) Tap the action item.
7. To test the macro, tap **Test**.
8. Tap **Save**. 

## Running a macro

Run a macro to make the projector perform a specific list of actions.

1. In the right toolbar, tap **Run Macro**. 
2. Tap a macro.

## Adding an action item to an existing macro

Add an action item to a macro to have the projector perform an additional action when the macro runs.

1. In the left navigation menu, tap **Automation > Macro Editor**.
2. In the top right pane, select a macro from the list.
3. Add an action item to the macro:
  - a) In the left pane, expand the **My Auditorium** list.
  - b) Under Automation, Playback, or Projector, select the action item.
4. To save the macro, tap **Save**. 
5. To test the macro, tap **Test**.

## Adding a macro to an existing macro

Combine macros to have the projector complete a complex set of actions.

1. In the left navigation menu, tap **Automation > Macro Editor**.
2. From the list in the top right pane, select a macro.

3. In the left pane, expand the macro list.
4. Tap a macro.
5. Tap **Save**. 

## Deleting a macro

Delete macros when they are no longer required.

1. In the left navigation menu, tap **Automation > Macro Editor**.
2. From the list in the top right pane, select a macro.
3. Tap **Delete**. 
4. To confirm the deletion, tap **Delete**.

## Adding an automation device to your auditorium

Add an automation device so it can be controlled remotely and can communicate with other theater hardware.

1. In the left navigation menu, tap **Automation > My Auditorium Devices**.
2. Tap **+ New Device**.
3. In the Name field, type a name for the device.
4. In the Device Type list, select the device type.
5. In the Select Device list, select the device.
6. Tap **Add**.
7. Complete these fields:
  - IP Address—The IP address of the automation device.
  - Port—The port used by the automation device to communicate with the projector.
  - Username—The username used to access the automation device.
  - Password—The password used to access the automation device.
  - Keep Alive Message—The message value that is sent to the automation device to ensure the projector is not disconnected when inactive.
  - Keep Alive Interval (ms)—The time interval (in microseconds) for sending the Keep Alive Message to the automation device.
8. Tap **Save**.

## Modifying automation device settings

Modify the settings of automation devices when parameters such as the user name or password change. If the settings are not updated, the automation device might be unable to communicate with other theater hardware or be controlled remotely.

1. In the left navigation menu, tap **Automation > My Auditorium Devices**.

2. In the left pane, select an automation device.
3. Modify these fields:
  - IP Address—The IP address of the automation device.
  - Port—The port used by the automation device to communicate with the projector.
  - Username—The username used to access the automation device.
  - Password—The password used to access the automation device.
  - Keep Alive Message—The message value that is sent to the automation device to ensure the projector is not disconnected when inactive.
  - Keep Alive Interval (ms)—The time interval (in microseconds) for sending the Keep Alive Message to the automation device.
4. Tap **Save**.

## Removing an automation device from your auditorium

Remove an automation device when it is no longer required, or it has been physically removed from the theater.

1. In the left navigation menu, tap **Automation > My Auditorium Devices**.
2. In the left pane, select an automation device.
3. Tap **Delete**. 
4. To confirm the deletion, tap **Delete**.

## Creating a new playlist trigger

Create new playlist triggers to activate an automation device in a playlist.

1. In the left navigation menu, tap **Automation > Device Input Triggers**.
2. Tap the **Playlist Trigger** tab.
3. Tap **+ New Playlist Trigger**.
4. Complete the Name, Device Source, and Resume Playback On fields.
5. Tap **Add**.

## Editing existing playlist trigger settings

Edit playlist trigger settings to change the playlist trigger behavior.

1. In the left navigation menu, tap **Automation > Device Input Triggers**.
2. Tap the **Playlist Triggers** tab.
3. To the right of the playlist trigger you want to edit, tap **Edit**. 
4. Edit the playlist trigger settings.



5. Tap **Save**.

## Deleting a playlist trigger

Delete a playlist trigger when it is no longer required.

1. Tap **Automation > Device Input Triggers**.
2. Tap the **Playlist Triggers** tab.
3. To the right of the playlist trigger, tap **Delete**. 
4. To confirm the deletion, tap **Delete**.

## Creating a new global trigger

Create a global trigger to trigger an output macro. For example, a fire alarm input signal could cause playback to stop and the house lights to come on. A global trigger is always active and is not dependent on specific playlist definitions.

1. In the left navigation menu, tap **Automation > Device Input Triggers**.
2. Tap the **Global Triggers** tab.
3. Tap **+ New Global Trigger**.
4. Complete the Name, Source, and Trigger Event fields.
5. In the Macro Name list, tap the macro that will run on trigger detection.
6. Tap **Add**.

## Editing existing global trigger settings

Edit the settings of an existing global trigger to change its behavior.

1. In the left navigation menu, tap **Automation > Device Input Triggers**.
2. Tap the **Global Triggers** tab.
3. To the right of the global trigger you want to edit, tap **Edit**. 
4. Edit the global trigger settings.
5. Tap **Save**.

## Deleting a global trigger

Delete a global trigger when it is no longer required.

1. In the left navigation menu, tap **Automation > Device Input Triggers**.
2. Tap the **Global Triggers** tab.
3. To the right of the global trigger, tap **Delete**. 
4. To confirm the deletion, tap **Delete**.

## Importing a device library

A device library contains commands that are used to control a specific device.

1. In the left navigation menu, tap **Automation > Device Libraries**.
2. Tap **Import Device Library**.
3. Browse to the location of the device library file.
4. Tap the file and tap **Accept**.

## Viewing a device library

View device libraries to determine if a library exists for the network device.

1. Import the device library.
2. In the left navigation menu, tap **Automation > Device Libraries**.
3. To the right of the device in the View Library column, tap **View Library**. 

Review the list of actions available for the device.

## Deleting a device library

Delete a device library when it is no longer required.

1. In the left navigation menu, tap **Automation > Device Libraries**.
2. To the right of the device library, tap **Delete**. 
3. To confirm the deletion, tap **Delete**.

# Enhancements and licensing

Learn about importing licenses and activating product enhancements.

## Importing a product enhancement

Import a license to activate a product enhancement.

1. Tap **Service Setup > Enhancements**.
2. Tap **Import License**.
3. Browse to the location of the license.
4. Select the license and tap **Accept**.

## Enabling an enhancement

After importing a license, it must be enabled to activate the new functionality.

1. Tap **Service Setup > Enhancements**.
2. *Import the license* (on page 83).
3. Tap the **Enhancement** slider.  
The color of the slider changes to green to indicate it is active.

# Backup, restore, and upgrade projector files

Learn how to back up, restore, and upgrade projector files.

## Creating a new backup file

Create a new backup file to restore projector settings if a failure occurs.

1. In the left navigation menu, tap **Service Setup** > **Backup and Restore**.
2. Tap **New Backup**.
3. Type a name for the backup file and tap **Backup**.

## Exporting a backup file

A disaster recovery plan can include exporting backup files to another location.

1. In the left navigation menu, tap **Service Setup** > **Backup and Restore**.
2. Insert a USB flash drive into the **Management USB** port on the projector communication board.
3. Select a backup file and tap **Export**. 
4. Tap to move up through the file directory.
5. Tap to create a new folder.
6. In the Name field, type a name for the backup file.
7. Tap **Accept**.

## Importing a backup file

Import a backup file to restore projector settings.

1. In the left navigation menu, tap **Service Setup** > **Backup and Restore**.
2. Insert a USB flash drive into the **Management USB** port on the projector communication board.
3. Tap **Import Backup**.
4. Browse to the location of the file or enter a name for the backup file in the Name field.
5. Select the file and tap **Accept**.

## Sorting backup files by name and date created

Locate a backup file with a specific name or creation date.

1. In the left navigation menu, tap **Service Setup** > **Backup and Restore**.
2. Sort the backup files:
  - To sort the backup files by name, tap the **Backup File Name** heading.
  - To sort the files by the date they were created, tap the **Date Created** heading.

## Deleting a backup file

Delete a backup file if it is no longer required or is uploaded in error.

1. In the left navigation menu, tap **Service Setup** > **Backup and Restore**.
2. Select a backup file and tap **Delete**. 
3. To confirm, tap **Delete**.

## Adding an upgrade package

An upgrade package is used to upgrade the projector software.

A maximum of 10 upgrade packages can be stored. When you add an upgrade package that exceeds this limit, the system deletes the upgrade package that was last used.

1. In the left navigation menu, tap **Service Setup** > **System Upgrade**.
2. Tap **+ Add New Package**.
3. Browse to the location of the upgrade package.
4. Type a name for the upgrade package and tap **Accept**.

## Viewing a list of available upgrade files

Select a specific upgrade file to install from a list of upgrade files.

- In the left navigation menu, tap **Service Setup** > **System Upgrade**. A list of upgrade files appears in the left pane.

## Installing an upgrade package

Install an upgrade package to update the projector software.

1. In the left navigation menu, tap **Service Setup** > **System Upgrade**.
2. In the list of packages, tap an upgrade package.
3. In the right pane, select one of these options:
  - **Upgrade Differences Only**—Upgrades system components that are newer or older than the currently installed version.

- **Force Upgrade All**—Upgrades all components in the upgrade package.
  - **Factory Upgrade**—Removes all existing configurations and upgrades all components.
4. Tap **Upgrade**.
  5. To confirm, tap **Upgrade**.

## Comparing upgrade packages

Compare upgrade packages to view the differences between them.

1. In the left navigation menu, tap **Service Setup** > **System Upgrade**.
2. In the list of packages, tap an upgrade package.  
The differences between the current and the selected upgrade package are displayed in the right pane. Differences are identified with a yellow exclamation mark.

## Deleting an upgrade package

Delete an upgrade package that is no longer required.

1. In the left navigation menu, tap **Service Setup** > **System Upgrade**.
2. In the list of packages, tap an upgrade package.
3. Tap **Delete**. 
4. To confirm the deletion, tap **Delete**.

## Restoring settings from a backup file

Restore projector settings from a backup file.

1. In the left navigation menu, tap **Service Setup** > **Backup and Restore**.
2. Select a backup file and tap **Restore**. 
3. Select the settings you want to restore and tap **Restore**.
4. Tap **OK**.

## Restoring factory default settings

Restoring factory settings removes all custom projector settings.

1. In the left navigation menu, tap **Service Setup** > **Backup and Restore**.
2. Tap **Factory Restore**.
3. Select the settings you want to restore and tap **Restore**.
4. Tap **OK**.

# Accessing projector diagnostics

Learn how to access projector system logs and run diagnostic utilities.

## Retrieving and downloading system logs

System logs can aid with the identification and correction of projector faults.

1. In the left navigation menu, tap **Diagnostics > System Logs/Interrogator**.
2. In the From list, select a start date for the logs.
3. In the To list, select an end date for the logs.
4. In the Log Source list, select a log type. For example, **Projector**.
5. Tap **Search**.
6. To sort log files by type, message, or date, tap a column heading.
7. To download the SM report:
  - a) Tap **Download SM Report**.
  - b) Browse to the location where you want to save the report file.
  - c) Type a name for the report file in the Name field.
  - d) Tap **Accept**.

## Running the projector interrogator

Run the interrogator to identify and correct projector faults.

1. Insert a USB flash drive in the **Management USB** port on the projector communication board.
2. In the left navigation menu, tap **Diagnostics > System Logs/Interrogator**.
3. Tap **Run Interrogator**.
4. Tap **Interrogate**.
5. Browse to the location where you want the interrogator file to be saved.
6. In the Name field, type a name for the interrogator file.
7. Tap **Accept**.

## Downloading a certificate

Use a certificate to request Key Delivery Message (KDM) keys.

1. In the left navigation menu, tap **About**.
2. In the certificate list, select one of the following certificates:
  - Projector Certificate
  - SMS Certificate
  - SM Certificate (used by distributors to generate KDM keys)
  - Log Signer Certificate
3. Tap **Download**.
4. In the Name field, type a name for the certificate file.
5. Tap **Accept**.



# Maintaining the projector

Learn the information and procedures for performing projector maintenance.

Read through this section in its entirety before performing maintenance activities. When performing projector maintenance, obey all warnings and precautions.



**Warning!** If not avoided, the following could result in death or serious injury.

- SHOCK HAZARD! Disconnect the product from AC before installing, moving, servicing, cleaning, removing components, or opening any enclosure.
- Do not operate the cinema projector without all of its covers in place.
- Do not operate the cinema projector without all of its covers in place.



**Caution!** If not avoided, the following could result in minor or moderate injury.

- Christie products must be installed and serviced by Christie qualified technicians.
- Only Christie qualified technicians are permitted to open product enclosures.



**Notice.** If not avoided, the following could result in property damage.

- Observe all electrostatic precautions. Use a grounded wrist strap and insulated tools when handling, servicing, or cleaning electronic assemblies.
- Always wear clean, powder-free latex gloves when handling optical components.

## Inspecting ventilation

Vents and louvers in the projector covers provide ventilation, both for intake and exhaust.

Never block or cover these openings. Do not install the projector near a radiator, heat register, or within an enclosure.

To ensure adequate airflow around the projector, keep a minimum clearance of 50cm (19.69”) on the left, right, and rear sides of the projector.

## Inspecting and cleaning the lamp

Inspect the contact surfaces of the lamp connections.



**Warning!** If not avoided, the following could result in death or serious injury.

- SHOCK HAZARD! Disconnect the product from AC before installing, moving, servicing, cleaning, removing components, or opening any enclosure.
- EXPLOSION HAZARD! Always wear manufacturer approved protective safety clothing (gloves, jacket, face shield) whenever the lamp door is open or when handling the lamp. Any local or federal specifications take precedence over Christie's protective clothing recommendations.

- Check the contact surfaces of the anode (positive) and the cathode (negative) connections for cleanliness.
- Clean electrical contact surfaces every 5000 hours or after two lamp changes to prevent contact resistance from scorching connectors. Use an approved contact cleaner.
- Verify that all electrical and lamp connections are secure.

## Inspecting and cleaning optics

Inspect and clean optical components such as the projection lens to ensure optimum image display.

Unnecessary cleaning of optics can increase the risk of degrading delicate coatings and surfaces. A small amount of dust or dirt on the lens has minimal effect on image quality-to avoid the risk of scratching the lens, clean the lens only if absolutely required.

Typically, optical components do not need to be cleaned frequently if they are installed and operated in a location that meets or exceeds the environmental standard recommended by Christie. Christie recommends that all cinema projectors are installed and operated in an environment that meets or exceeds Underwriters Laboratories (UL) standard 609.50 Pollution Degree 2 and ISO Class 9 Standard for Office Environments.



**Notice.** If not avoided, the following could result in property damage.

- Christie products must be installed and serviced by Christie qualified technicians.
- Always wear clean, lint-free gloves when handling the UV filter.
- Do not reuse lens tissues.
- Always handle optics by their edges.

## Recommended service kit

Use the following recommended tools to clean the optics.

- Powder-free latex gloves
- Soft camel-hair brush
- Dust-free blower - air bulb or a canned air duster without additives such as Techspray 1671-10S Ultra-Pure Duster
- Lint-free lens tissue, such as Lensx 90 tissue or Newport Optics cleaning tissue
- Lens cleaning solution and a microfiber cloth (for the lens only)
- Optical grade cotton swabs with wooden stems
- A bright, portable illumination device such as an LED flashlight

## Cleaning the lens

To avoid the risk of scratching the lens, clean the lens only if absolutely required.

A small amount of dust or dirt on the lens has minimal effect on image quality.

# Installing the lamp

Complete the following procedure to install the lamp.



**Warning!** If not avoided, the following could result in death or serious injury.

- This procedure must be performed by Christie qualified technicians.
- EXPLOSION HAZARD! Always wear manufacturer approved protective safety clothing (gloves, jacket, face shield) whenever the lamp door is open or when handling the lamp. Any local or federal specifications take precedence over Christie's protective clothing recommendations.
- Do not open the lamp door while the lamp is on.
- EXPLOSION HAZARD! Allow sufficient time for the lamp to cool down before powering down the product, disconnecting it from AC, and opening the lamp door.
- EXPLOSION HAZARD! Do not stress the glass of a lamp or bare bulb in any way.
- EXPLOSION HAZARD! Lamps and bare bulbs, even when packaged, may explode if dropped or mishandled.



**Caution!** If not avoided, the following could result in minor or moderate injury.

- Improper installation of the lamp can damage the projector.
  - Incorrect lamp power supply and igniter connections can damage the product.
1. If the projector is operating, turn it off and allow it to cool a minimum of 15 minutes.
  2. Turn the breaker switch for the projector off.
  3. Disconnect the projector from AC power.
  4. Disconnect the touch panel communication cable from the rear of the projector.
  5. Remove the touch panel from the rear of the projector.
  6. Put on your protective clothing, face shield, and gloves.
  7. Insert the key in the lamp door lock, turn the key, and then open the lamp door.
  8. Loosen the two thumbscrews and open the firewall door.
  9. Loosen the two thumbscrews and open the lamp access door.
  10. Loosen the cathode clamp with the 5 mm hex key attached to the lamp door.

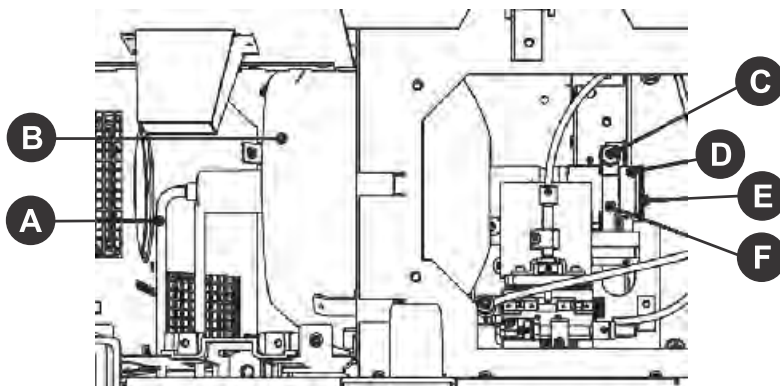

A	Anode wire
B	Reflector
C	Cathode clamp

D	Extension nut (for CDXL-14 and CDXL-16)
E	Cathode nut
F	Cathode clamp

11. For CDXL-14 or CDXL-16 lamps:



**Warning!** If not avoided, the following could result in death or serious injury.

- EXPLOSION HAZARD! Handle a lamp by the cathode and anode end shafts only. Do not handle the lamp by the glass.
  - EXPLOSION HAZARD! Do not over-tighten the lamp.
  - EXPLOSION HAZARD! Do not stress the glass of a lamp or bare bulb in any way.
- a) Install the lamp extension nut on the cathode clamp. To provide access to the locking screw on the extension nut, rotate the extension nut until the locking screw faces upward toward the projector lid.  
The extension nut is only used with CDXL-14 and CDXL-16 lamps.
  - b) Thread on and hand-tighten the cathode nut. Ensure the smooth portion of the nut is against the cathode clamp.
  - c) Hold the anode end of the new lamp in your left hand and angle it up through the hole in the back of the reflector assembly. Insert your right index and middle finger through the back of the reflector and thread the cathode end of the lamp into the extension nut.  
Check all leads. When threading the lamp into the extension nut, make sure the anode (+) wire does not touch any projector metal, such as the reflector or firewall.
  - d) Tighten the extension nut screw.
  - e) Move to step 13.
12. For CDXL-19SC or CDXL-21S1 lamps:
- a) Hold the anode end of the new lamp in your left hand and angle it up through the hole in the back of the reflector assembly.
  - b) Insert your right index and middle finger through the back of the reflector and guide the lamp onto the cathode clamp.  
Be careful not to hit the lamp against the reflector.
  - c) Thread on and hand-tighten the cathode nut. Ensure the smooth portion of the nut is against the cathode clamp.
  - d) Tighten the cathode screw (D) with a hex key.
13. Align the ring terminal on the anode wire with the mounting position ensuring the crimped side of the wire is facing out.
14. Tighten the anode screw.
15. Route anode lead away from nearby metal surfaces.
16. Close the lamp access door and tighten the two thumbscrews.
17. Close the fire wall door and tighten the two thumbscrews.
18. Close and lock the rear access door. Ensure the hex key is placed back into its holder before closing the rear access door.

## Inspecting the card cage filter

Check the condition of the card cage air filter monthly. Clean or replace the card cage air filter sooner if you are operating the projector in a dusty or dirty environment.

The filter is located on the left side of the projector behind the air filter cover. Use only high efficiency Christie approved filters.

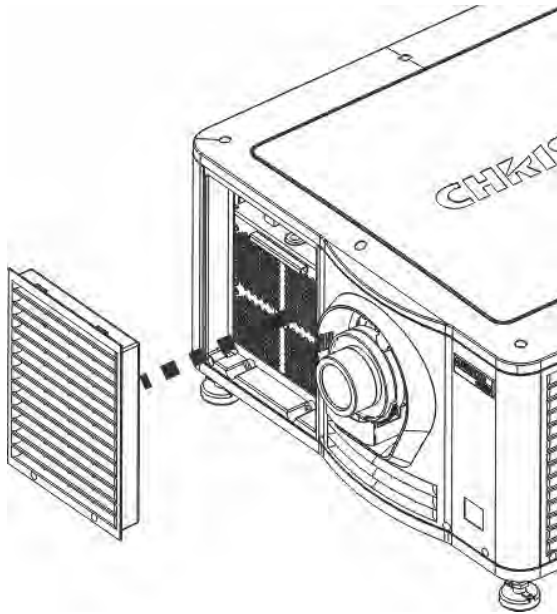

**Caution!** If not avoided, the following could result in minor or moderate injury.

- Do not operate the product without the filter installed.
- Do not reuse an old air filter.

1. Loosen the two captive screws on the bottom of the filter cover.
2. Pull the cover out and down.
3. Slide the air filter out and inspect it.  
If the filter appears dirty and you cannot see through it, replace it with a new paper filter, or *clean it* (on page 95) if it is a washable filter.  
If the filter appears clean, continue to step 4.
4. Replace the air filter with the airflow indicator facing toward the projector.
5. Install the air filter cover by inserting the two bottom tabs and then pushing the cover closed.
6. Tighten the two captive screws.

## Inspecting the light engine compartment filter

The filter is located on the right side of the projector behind the service access panel.

1. Remove the top lid.
2. Reach into the projector and then loosen the first service panel screw.

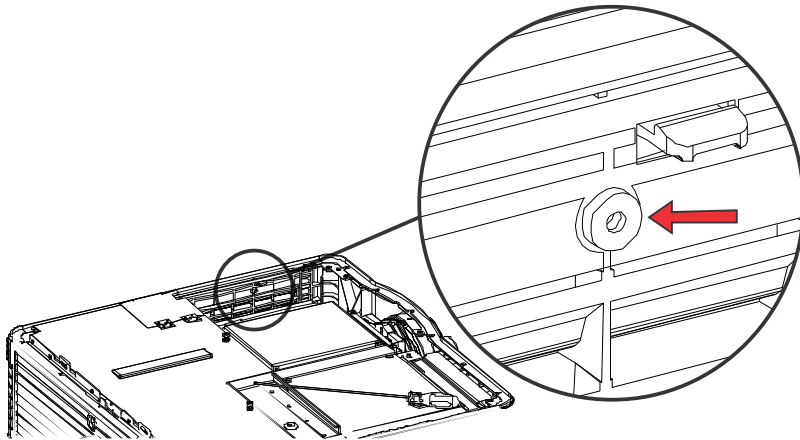

3. Open the integrator rod access door and loosen the second service panel screw.

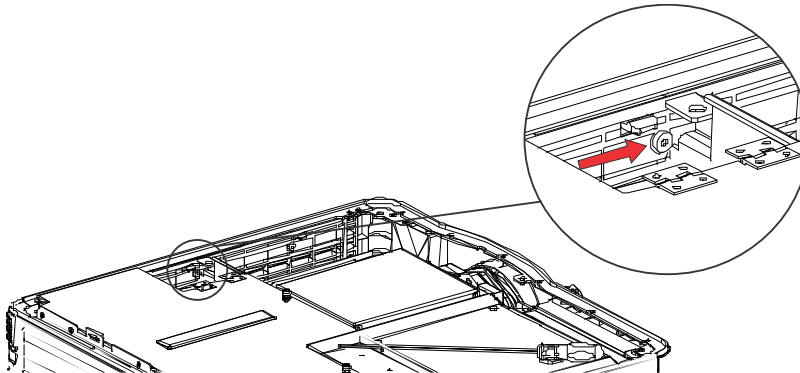

4. Push the clips on the top of the service panel down and out to remove the service panel.

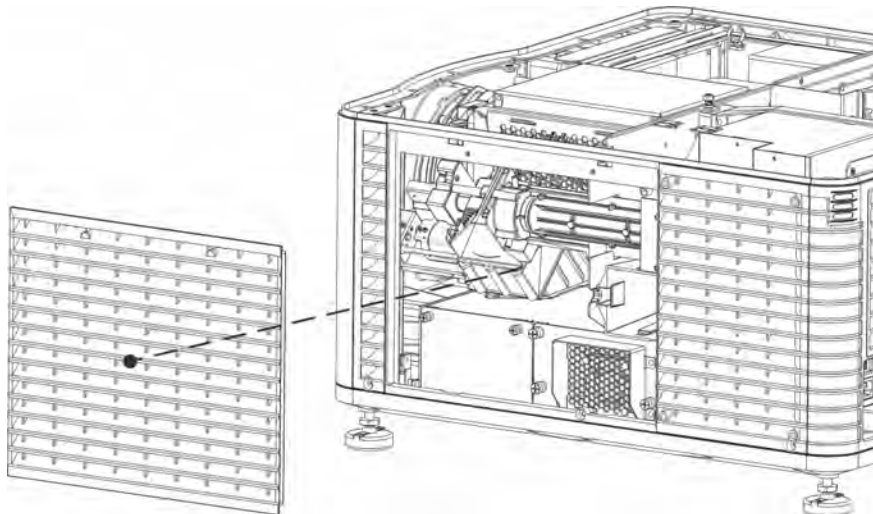

5. Loosen the two captive screws on the cap plate and then remove it.

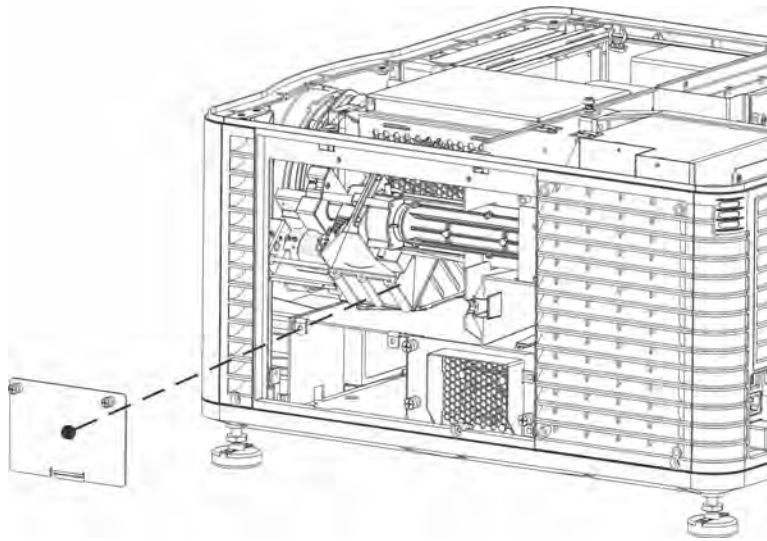

6. Slide the air filter out and inspect it.  
If the filter appears dirty and you cannot see through it, replace it with a new paper filter, or clean it if it is a washable filter.  
If the filter appears clean, continue to step 7.
7. Replace the air filter with the airflow indicator facing toward the projector.
8. Install the cap plate and tighten the two captive screws.
9. Install the service panel and then tighten the two screws.
10. Install the top lid.

## Cleaning a washable filter

If the amount of dirt on the filter is minimal, use a vacuum or compressed air to remove it. If you use compressed air, the air must move through the filter in the opposite direction of the air flow indicator on the side of the filter.



**Caution!** If not avoided, the following could result in minor or moderate injury.

- Install dry filters only. Wet or damp filters can cause an electrical short and damage the product.
1. Hold the filter on an angle under warm running water so the water flows through the filter in the opposite direction of the air flow indicator on the side of the filter.
  2. Rinse the filter thoroughly.
  3. Submerge the filter for a minimum of 30 minutes in a container of warm water and two tablespoons of mild detergent or liquid dish soap.  
If the filter is extremely dirty, move the filter from side-to-side occasionally or remove the excess dirt by brushing both sides of the filter with a soft brush.
  4. Rinse the filter thoroughly by holding it on an angle under cool running water.  
The air flow arrow on the side of the filter should face down.
  5. If the filter still appears dirty, repeat steps 3 and 4.
  6. Shake the filter over a container until most of the water is removed.



7. Place the filter on its edge on a flat, stable surface and allow it to dry thoroughly.
8. To confirm that the filter is dry, place it over a dry paper towel and shake it.  
If the paper towel remains dry, the filter can be installed in the projector.
9. Record the date the filter was cleaned.
10. Replace the filter following the instructions for the specific filter.

## Replacing the lens

The lens seals the projection head, preventing contaminants from entering the main electronics area. Do not operate the projector without a lens installed. Install a lens plug when you install or transport the projector.

1. On the touch panel Main screen, tap and hold the power button to turn off the lamp and projector.
2. Allow the lamp to cool for a minimum of 15 minutes.
3. Disconnect the projector from AC power or turn the circuit breaker off.
4. Remove the lens surround.
5. Install the lens cap and turn the lens clamp to the open position with a hex key.
6. If necessary, remove the two cap screws securing the lens to the lens mount using a hex key.

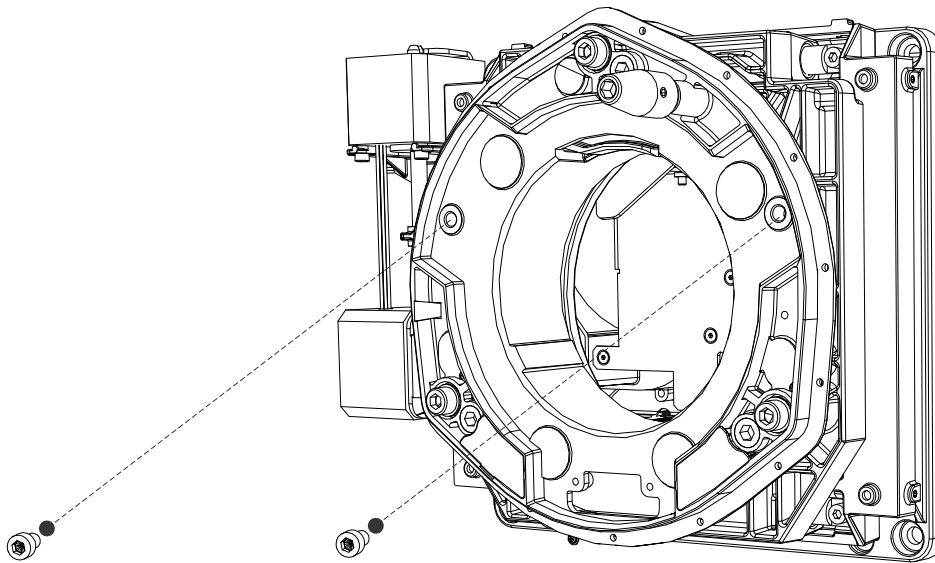

7. Pull the lens out of the lens mount and then install a small lens cap on the rear of the lens.
8. Remove the small rear cap from the new lens.  
Keep the front cap on.
9. Align the tabs on the lens plate with the lens mount.
10. Insert the lens until it connects with the magnets on the mount.  
When the lens contacts the magnetic plates it is seated correctly.
11. Secure the lens clamp by rotating it clockwise with a hex key.
12. Tighten the lens mount cap screws for added stability.



13. Replace the lens surround.
14. Remove the lens cap from the front of the lens.

# Troubleshooting

The following topics cover common projector issues and their solutions.  
If an issue cannot be resolved, contact a Christie qualified technician.

## Projector functionality

The following topics cover common projector issues and their solutions.

### Projector does not turn on

When I attempt to power on the projector, it does not turn on.

#### Resolution

- Verify the power cord is connected to the projector and the AC power supply correctly and the input selector switch is in the correct position.
- Verify the wall circuit breaker is on. If there is a problem with the wall circuit breaker turning off, contact a certified electrician.
- On the F-MAIN faceplate, verify the POWER LED is lit. When the harnessing, supply, and HUB boards are healthy, the POWER LED is either green or red in all powered states. A green LED indicates that the supply is healthy. A red LED indicates a failed power supply.
- If the POWER LED is green and additional LEDs are lit on the F-MAIN faceplate, record the color combination of the faceplate LEDs after they have been powered for at least 30 seconds. You can then provide the color combination information to Christie technical support.
- If the POWER, INPUT, HUB, and SMS LEDs are all green, but the touch panel still does not turn on or display an image, eliminate the cable and touch screen by connecting any external VGA display.

### Cannot establish communication with projector

The input devices cannot communicate with the projector.

#### Resolution

- Verify all input devices have the same subnet mask and gateway, and unique IP addresses.

## Lamp functionality

The following topics cover common lamp issues and their solutions.

### Lamp does not ignite

The projector is powered on but the lamp does not ignite.

#### Resolution

- In the left navigation menu, tap **Lamp Settings > Lamp Manager** and in the Lamp History list, verify the number of hours the lamp has operated. Replace a lamp nearing the end of its operational life.
- In the left navigation menu, tap **Status > Interlocks** and then check and correct all interlock failures.
- In the left navigation menu, tap **Status > All Alarms**. If a ballast communication error has occurred, restart the projector and turn the lamp on.
- In the left navigation menu, tap **Status > Temperatures** and verify if the DMD temperatures are too high. If the temperatures are too high, cool the projector. Ensure the projector is properly ventilated and the air filters are not blocked.
- Listen for a clicking noise that indicates the ballast is attempting to strike the lamp. If you do not hear a clicking noise, there might be a problem with the ballast. Contact a Christie accredited service technician to resolve the issue.
- If you hear a brief clicking noise, but the lamp does not ignite, replace the lamp.

### Lamp suddenly turns off

The lamp unexpectedly turned off.

#### Resolution

- In the left navigation menu, tap **Lamp Settings > Lamp Power/LiteLOC Setup**. Increase the lamp power.
- In the left navigation menu, tap **Status > Interlocks** and then check and correct all interlock failures.
- In the left navigation menu, tap **Status > Temperatures** and verify if the DMD temperatures are too high. If the temperatures are too high, cool the projector. Ensure the projector is properly ventilated and the air filters are not blocked.
- Replace the lamp.

## LiteLOC™ not working

Brightness settings are not being displayed at a constant level.

### Resolution

- In the left navigation menu, tap **Lamp Settings > Lamp Power/LiteLOC Setup**. Under LiteLOC™, tap **Enable LiteLOC**. 
- If the lamp power is at the maximum setting to maintain a LiteLOC setting, LiteLOC is automatically disabled. Reduce the LiteLOC setting, or install a new lamp.

## Display issues

The following topics cover common display issues and their solutions.

### Flicker, shadows, or dimness

The projected image flickers, contains shadows, or is dim.

### Resolution

- Verify that the douser is open.
- Align the lamp.
- In the left navigation menu, tap **Lamp Settings > Lamp Power/LiteLOC Setup**. Monitor the **Power %** field to determine if the power is consistent or if it varies. Increase the lamp power. Lamps that are near end of service may not operate reliably at a lower power setting.
- A fold mirror or integrator rod misalignment could exist. Contact your Christie qualified service technician to resolve the issue.

### Blank screen with no display of cinema image

When the projector is turned on, nothing is displayed.

### Resolution

- Ensure the lens cap is not on either end of the lens.
- Ensure the lamp is on.
- Confirm all power connections are still good.
- Ensure the douser is **open** by verifying the state of the douser on Main panel.
- Ensure any test pattern other than the full black test pattern displays properly.
- Verify the correct display file is selected.
- For cinema connections, verify the correct port is selected.

## Severe motion artifacts

The displayed image has artifacts such as smearing and double image perception.

### Resolution

- Verify if there is a synchronization problem with reversed 3-2 pull-down in the 60Hz-to-24Hz film-to digital conversion, and correct it at the source.

## Image is vertically stretched or squeezed

The image appears vertically stretched or squeezed into the center of the screen.

### Resolution

- In the left navigation menu, tap **Image Settings** > **Source File Setup** and verify the resolution and aspect ratio settings.
- In the left navigation menu, tap **Image Settings** > **Screen File Setup** and verify the lens factor settings.

## Inaccurate display colors

The colors in the image are not what I expected to see.

### Resolution

1. In the left navigation menu, tap **Channel Setup**.
2. In the left pane, select a channel.
3. In the PCF list, verify that the correct value is selected
4. In the **Color Space** field, verify that correct value is selected.

# CP2308 Specifications

Learn about the product specifications. Due to continuing research, specifications are subject to change without notice.

## Physical specifications

Learn the dimensions and weight of the projector.

Item	Description
Size (L x W x H) (without the lens, and with the feet at minimum length)	697 mm (32.70 inches) x 688 mm (27.10 inches) x 395 mm (15.60 inches)
Weight—installed with the lens	53.75 kg (119 lbs)
Shipping weight	77.2 kg (170 lbs)
Touch panel (W x H x D)	248.2 mm x 166.8 mm x 36.3 mm

## Power specifications

Learn the power requirements for the projector.

### AC input (A)

Item	Description
Voltage range	200 - 240 VAC
Line frequency	50/60 Hz nominal
Inrush current	100 A (at 240 VAC)
Current consumption	16 A maximum (at 200 VAC)
Power consumption	3200 W maximum
Current rating of AC input	IEC-320-C19/20 A

### UPS AC input (B)

Item	Description
Activation	Discrete switch above the power inlet cord(s)
UPS inlet connector (rating for powering main electronics)	IEC-320-C13/10 A, 240 VAC

Item	Description
UPS type	Universal 100-240 VAC
Line frequency	50/60 Hz nominal
Current consumption	4 A maximum (at 100 VAC)

## Environmental specifications

Learn about the environment requirements for projector while operating and not operating.

### Operating environment

Item	Description
Temperature	15°C to 35°C (59°F to 95°F)
Humidity (non-condensing)	20% to 80%
Altitude	0 - 3000 meters
Maximum ambient temperature	35°C

### Non-operating environment

Item	Description
Temperature	-20°C to 60°C (-4°F to 140°F)
Humidity (non-condensing)	0% to 95%

## Display specifications

Learn the display specifications of the projector.

### Panel resolution and refresh rate

Pixel format (H x V square pixels)	2048 x 1080
Processing path	23.97 - 120Hz

### Achievable brightness (measured at screen center)

Lamp	Minimum	Nominal	Maximum
700 W (CDXL-14M)	1,170 lumens	1,300 lumens	1,430 lumens
1.4 kW (CDXL-14M)	2,950 lumens	3,300 lumens	3,630 lumens
1.6 kW (CDXL-16M)	4,950 lumens	5,500 lumens	6,050 lumens
1.9 kW (CDXL-19SC)	6,300 lumens	7,000 lumens	7,700 lumens

Lamp	Minimum	Nominal	Maximum
2.1 kW (CDXL-21S1)	7,200 lumens	8,000 lumens	8,800 lumens

**Achievable contrast ratio**

400:1 ANSI
1900:1 Full Frame ON/OFF

**Color and gray scale**

Displayable colors	35.2 trillion
Gray scale resolution	45 bits total linear, 15 bits per RGB component

**White point**

Nominal White (full white, after calibration to Telecine mode, Theaters)
x = 0.314 ± 0.006
y = 0.351 ± 0.006

**Gamma**

Theater (nominal)	2.6 ± 5%
-------------------	----------

## Control signal compatibility

Learn the control signal compatibility for the projector.

**Ethernet port**

Interface	10Base-T/(IEEE 802.3)/100BASE-TX(IEEE 802.3u)/1000BASE-TX(IEEE 802.3ab)
Connector	Female RJ-45
Bit rate	1000 Mbps

**eSATA/USB 2.0 ingest**

Interface	USB 2.0/SATA revision 2.0
Connector	USB Type "A"/eSATA
Bit rate	480 Mbps/3.0 Gbps
Available power for devices	2A @ 5V (TBC)



**USB 3.0 ingest**

Interface	USB 3.0
Connector	USB Type "A"
Bit rate	5.0 Gbps
Available power for devices	2A @ 5V (TBC)

**GPIO port**

Interface	Opto-LED inputs, relay outputs
Number of I/O lines	16 - 4 inputs, 4 outputs, 1 health signal output
Connector	Terminal blocks
Wire size accepted	28-20 AWG
GPI diode forward current	5mA nominal, 50mA maximum
GPI diode forward voltage	1.1V nominal, 1.4V maximum (@ 5mA)
GPI relay continuous current	1A
GPO relay output rating	60V
Output supply voltage	5VDS @ 200 mA

**3D port**

Interface	Proprietary 3D connector
Connector	15-pin subminiature D, female
Bit rate	115,200 bps
Flow control	Software
Data format	1 start bit, 8 data, 1 stop bit, no parity
Communication protocol	RS232 and GPIO

**AES3 audio output**

Interface	16-Channel AES3 Digital Audio
Connector	RJ-45

**VGA user interface display**

Interface	VGA
Connector	15-pin high density subminiature D, female

**DVI user interface display**

Interface	DVI
Connector	24-pin DVI-I female

**USB touch panel input**

Interface	USB 2.0
Connector	USB Device Standard Size ("Series A")
Bit rate	480 Mbps

## Touch panel specifications

Learn the specifications of the touch panel.

Type of Display	Color LCD, backlit
Display Size	256.54 mm (10.1 inches) diagonal
Display Resolution (H x V pixels)	1280 x 800
Maximum Dimensions (W x H x D)	248.2 mm x 166.8 mm x 36.3 mm
Communication Interface with Projector	VGA/USB
Power Requirement	6W (12 V @ 500 mA)
Interface Connector	VGA/USB/ Power on custom cable

## Lamp specifications

Learn the specifications of the lamp.

Type: Xenon Short Arc Lamp

Projectors typically force a 10 minute cool down period. Ensure you do not re-strike the lamp any sooner than two minutes into this cool down period since hot re-strikes reduce lamp life. The period required to reach full brightness is 20 minutes (maximum).

**Power (software adjustable)**

Item	Description
CDXL-14M (1.4kW)	700 W min., 1400 W nom., 1540 W max.
CDXL-16M (1.6kW)	1000 W min., 1600 W nom., 1760 W max.
CDXL-19SC	1610 W min., 1900 W nom., 1900 W max.
CDXL-21S1 (2.1kW)	1260 W min., 2100 W nom., 2300 W max.

The ballast is power regulated and has a maximum current of 97 A. Therefore the maximum power specification for a given lamp may not be achievable until the lamp has aged, since lamp voltage increases with hours of use.

**Lamp expiry hours**

This table specifies the maximum hours the projector lamp can operate before replacement:

Lamp Type	Expected Life
CDXL-14M	3500 hours
CDXL-16M	3500 hours
CDXL-19SC	1800 hours
CDXL-21S1	1500 hours

## Accessories

Learn what accessories are available for the projector.

**Standard (sold with product)**

- Touch panel with interface cable
- User Manual (with USB flash drive containing additional technical documentation)
- Power Cord
- Lamp
- Lens
- Air Filters
- Stacking Kit

**Zoom lenses**

- 1.2-1.72 .69" DLPCine Zoom (108-494108-XX)
- 1.33-2.1 .69" DLPCine Zoom (108-495109-XX)
- 1.62-2.7 .69" DLPCine Zoom (108-496100-XX)
- 2.09-3.9 .69" DLPCine Zoom (108-497101-XX)

**Replacement lamps**

- CDXL-14M (003-003066-XX)
- CDXL-16M (003-003900-XX)
- CDXL-19SC (003-005366-XX)
- CDXL-21S1 (003-004258-XX)

### Air filters

- Replacement Light Engine Air Filter (003-004460-XX)
- Replacement Air Filter (003-002311-XX)
- Replacement Light Engine Washable Air Filter (003-004654-XX)
- Replacement Card Cage Washable Air Filter (003-004655-XX)

### Miscellaneous

- Rack Stand (108-416102-XX)
- Extractor Adapter Kit (119-103105-XX)

## Regulatory

This product conforms to the latest regulations and standards related to product safety, environmental requirements, and electromagnetic compatibility (EMC).

### Safety

- CAN/CSA C22.2 No. 60950-1
- ANSI/UL 60950-1 - Information Technology Equipment – Safety – Part 1: General Requirements
- IEC 60950-1 IEC/EN 60950-1 - Information Technology Equipment – Safety – Part 1: General Requirements
- EN 60950-1

## Electro-magnetic compatibility

### Emissions

- FCC CFR47, Part 15, Subpart B, Class A - Unintentional Radiators
- CAN ICES-003 (A)/NMB-003 (A) - Information Technology Equipment (Including Digital Apparatus) - Limits and Methods of Measurement
- CISPR 32/EN 55032, Class A

### Immunity

- CISPR 24/EN55024 EMC Requirements

## Environmental

EU Directive (2011/65/EU) on the restriction of the uses of certain hazardous substances (RoHS) in electrical and electronic equipment and the applicable official amendment(s).

EU Regulation (EC) No. 1907/2006 on the registration, evaluation, authorization and restriction of chemicals (REACH) and the applicable official amendment(s).

EU Directive (2012/19/EU) on waste and electrical and electronic equipment (WEEE) and the applicable official amendment(s).

China Ministry of Information Industry (along with 7 other Government Agencies) Order No.32 (01/2016) on the control of pollution caused by electronic information products, hazardous substances concentration limits (GB/T 26572 - 2011), and the applicable product marking requirement (SJ/T 11364 - 2014).

International packaging recycling mark requirements.

- EU Directive (94/62/EC) on packaging and packaging waste
- China packaging recycling mark standard (GB18455-2010)

## Corporate offices

---

Christie Digital Systems USA, Inc.  
Cypress  
ph: 714 236 8610

Christie Digital Systems Canada Inc.  
Kitchener  
ph: 519 744 8005

## Worldwide offices

---

Australia  
ph: +61 (0) 7 3624 4888

Brazil  
ph: +55 (11) 2548 4753

China (Beijing)  
ph: +86 10 6561 0240

China (Shanghai)  
ph: +86 21 6278 7708

France  
ph: +33 (0) 1 41 21 44 04

Germany  
ph: +49 2161 664540

India  
ph: +91 (080) 6708 9999

Japan (Tokyo)  
ph: 81 3 3599 7481

Korea (Seoul)  
ph: +82 2 702 1601

Mexico  
ph: +52 55 4744 1790

Republic of South Africa  
ph: +27 (0)11 510 0094

Russian Federation  
and Eastern Europe  
ph: +36 (0) 1 47 48 100

Singapore  
ph: +65 6877 8737

Spain  
ph: +34 91 633 9990

United Arab Emirates  
ph: +971 4 3206688

United Kingdom  
ph: +44 (0) 118 977 8000

United States (Arizona)  
ph: 602 943 5700

United States (New York)  
ph: 646 779 2014

## Independant sales consultant offices

---

Italy  
ph: +39 (0) 2 9902 1161



For the most current technical documentation, visit [www.christiedigital.com](http://www.christiedigital.com).

