



# CHRISTIE<sup>®</sup> MICROTILES<sup>™</sup>

THE NEW DIGITAL CANVAS





Visit Our  
**Latest Exhibit**  
National Art Gallery | Hall C



## ENGAGING, ENTERTAINING AND INFORMING

Christie knows what it takes to design and deliver the world's most advanced visual communication technologies. From our award winning history in film projection to our leadership position in digital cinema and large audience displays, we celebrate innovation.

With expertise in professional digital media display systems since the 1970s, Christie has established a global reputation as the leading provider of a variety of advanced visual communication technologies and solutions. Utilizing DLP, LCD and LED technologies, our broad range of solutions includes media walls, digital cinema projectors, networking solutions, and cutting edge 3D, virtual reality and simulation solutions.

And this year, we introduce the new digital canvas - Christie MicroTiles™ - the world's first fully-creative modular display solution.

A global organization with 13 offices around the world we help our customers communicate their message, their stories and their information. The world's most discerning customers choose Christie to present their vision and brand including Disney, the BBC, Toyota, AT&T, Cannes International Film Festival, NASDAQ, Harrods, China Film Council and NASA. That's good company to keep.

Christie is a wholly owned subsidiary of Ushio of Japan (JP:6925).

# CHRISTIE MICROTILES - THE NEW DIGITAL CANVAS

Christie MicroTiles provide the capability to capture your audience's attention - your way, just as you envisioned it, without having to worry if there is a technology out there worthy of displaying your content. Uniting spectacular colors, superior image quality and modular flexibility like no other visual solution can; Christie MicroTiles are designed to meet your needs.

Taking display technology to a new level, Christie MicroTiles are built on proven DLP technology and specifically designed for maximum image quality in demanding indoor, high ambient light environments. Christie MicroTiles are ideal for a wide range of demanding applications, including architectural elements, out-of-home advertising, command and control video walls, and event production.

Leveraging the strengths of both DLP projection and Light Emitting Diode (LED) technology, Christie MicroTiles offer substantially brighter images and a much wider color palette than conventional flat panel LCD and plasma displays. With no practical limit to the number of tiles in a display, Christie MicroTiles produce a virtually seamless canvas with an unlimited number of super-fine pixels.





# WELCOME

## AMPERSAND TECHNOLOGY

SALES MEETING | 9 AM-5 PM | BOARDROOM [B]

### SALES | 3<sup>RD</sup> FLOOR



### FINANCE | 2<sup>ND</sup> FLOOR



### HUMAN RESOURCES | 1<sup>ST</sup> FLOOR





# FREEDOM TO DESIGN



HOTELS

MUSEUMS

BUILDING  
FACADES

PUBLIC SPACES

CORPORATE  
LOBBIES

WAY FINDING

When you've labored over blueprints and dreamt of the perfect display, why compromise on the final product? With its "building block" format and small footprint, Christie MicroTiles bestows the ultimate design freedom to specify and create a digital media display that fits any commercial or public space.

With an unobtrusive, modular building block design, Christie MicroTiles seamlessly blend into any environment, allowing your audience to focus on the intended message and not the technology being used to display it. Christie MicroTiles have the right combination of high brightness and rich contrast for demanding indoor, high ambient light environments. There's no glare or distracting reflections so your message is always clear.

**Design freedom:** Designers can specify any size, and any shape display to fit their intended environment. The form factor is narrow and easy to incorporate into a building design. Consider this another building material created to make your dreams a reality.

**Amazing image quality:** Amalgamating the strengths of LED and DLP technology, Christie MicroTiles offer a color range that far exceeds conventional LCD and plasma technologies.

**Optimal viewing angles:** Other display options force audiences into awkward angles and distances to truly 'see' your message. Up close or from a distance, Christie MicroTiles deliver crisp, high-resolution images at any viewing angle.

**Easy set-up:** Weighing in at only 20lbs (9.2kg) these lightweight tiles lock together quickly and easily, making creativity fun again. Create unique sizes and shapes in a snap.

**Low operating costs:** When you make a significant investment you want it to last. Christie MicroTiles are more reliable and more serviceable than traditional display technologies. We've raised the bar - imagine 24/7 operation for more than 7 years. Put another way, that's 65,000

hours before your tiles reach half brightness.

**Environmental sensitivity:** Christie is conscious of the push towards greener solutions. That's why we've created a product with no consumables. No consumables are a big deal in today's environment. We're RoHS compliant and have built-in eco-power consumption modes. Christie MicroTiles are an ideal choice for LEED projects, and for any building where environmental standards must be met.

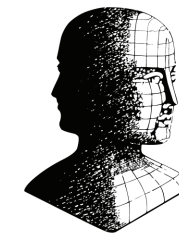

**JANUS 2010  
DE L'INDUSTRIE**

▲ Christie MicroTiles won the prestigious 2010 Janus de l'Industrie Award from the French Institute of Design.



# SCORE BOARD

BRONCOS	1 - 1	BULLDOGS
EAGLES	2 - 0	PHOENIX
HURRICANE	1 - 0	LIONS
RAPTORS	1 - 1	CHARGERS
DEVILS	0 - 2	KNIGHTS



CHECK OUT THE BRONCOS' TEAM STORE ON LEVEL 2 FOR OFFICIAL TEAM MERCHANDISE | VISIT [WWW.BRONCOS\\_FOOTBALL.COM](http://WWW.BRONCOS_FOOTBALL.COM) FOR VIDEO HIGHLIGHTS AND PLAYER STATS | CHECK OUT THE BRONCOS' TEAM STORE ON LEVEL 2 FOR OFFICIAL TEAM MERCHANDISE | VISIT [WWW.BRONCOS\\_FOOTBALL.COM](http://WWW.BRONCOS_FOOTBALL.COM) FOR VIDEO HIGHLIGHTS AND PLAYER STATS



BROADCAST

LIVE THEATER



TRADE SHOWS

SPORTING  
EVENTS

## EVENT PRODUCTION

# FREEDOM TO ATTRACT

Events are even more spectacular when the visual media presentation has the power to captivate audiences up close or from a distance. Whether your event is a nightly broadcast to millions of viewers, a Broadway play, a major sporting event or a live performance, Christie MicroTiles deliver bright, bold images that are sure to engage and entertain audiences every time.

Built to last and easy to maintain, Christie MicroTiles deliver eye-catching image quality you can rely on day after day. These lightweight modules lock together in seconds to form any size or shape digital display. We've designed Christie MicroTiles with you in mind and we believe we thought of everything - you be the judge, we don't think you'll be disappointed.

**Vast viewing angles:** With Christie MicroTiles, viewing angle and distance are not a factor. Whether you're up close, far away or off on an angle, images remain clear and sharp.

**Amazing image quality:** Amalgamating the strengths of LED and DLP technology, Christie MicroTiles offer a color range that far exceeds conventional LCD and plasma technologies.

**Automatic color matching:** Christie MicroTiles' built-in, intelligent, auto-calibration feature ensures that images look great every time an array is assembled, without time-consuming, costly human intervention. They also continuously auto-calibrate for color and brightness, self-correcting as they go. With true blacks and vibrant saturated colors, Christie MicroTiles create stunning images time and again.

**Easy set-up:** Weighing in at only 20lbs (9.2kg) these lightweight tiles lock together quickly and easily.

**Simple service access:** In event production, every minute counts. Christie MicroTiles are designed so that all of the internal components are easily accessible from the front - allowing for quick service without bringing down your entire array.

**Pre-staging design tool:** Save time designing your display and determining the exact quantities required. Christie MicroTiles Designer™ software generates a simulation of your installation, based on the exact dimensions you provide. If you need to modify your design, simply adjust the dimensions in Christie MicroTiles Designer and you'll have a new simulation and list of required components.





EVENT: PRESIDENTIAL VISIT  
FRIDAY, SEPTEMBER 25, 2013

MONITORING & SURVEILLANCE  
DEPARTMENT

TIME	SEARCH	RELATIVE DIRECTION	TEXT MESSAGE
10:00:00	10/0000	00000	10/0000
10:00:00	10/0000	00000	10/0000
10:00:00	10/0000	00000	10/0000

37°  
Wind: 10 mph NNE  
Hum: 25%  
Rain: 20%

AIR TRAFFIC

TELECOMMUNICATIONS

WEATHER CONDITIONS

LIVE VIDEO FEEDS

PUBLIC TRANSPORTATION: GRID AND VIDEO FEED







*Give the gift*  
that will last a lifetime

*Visit kiosk*  
for limited time offer

ON SALE  
NOW

*Watches*  
for all times



# FREEDOM TO ENGAGE

What's your vision? Where do you see your message? If it's in lights - bright lights - in the most highly visible spaces, Christie MicroTiles are your choice for display technology. This revolutionary new digital canvas gives you the power to display your images just the way you imagined them, where you imagine them. With a footprint of only 10 x 16" (260 x 408mm), and weighing only 20lbs (9.2kg) you can stack them in any shape, in any size, in any venue! Each tile contains color and brightness sensors, enabling the entire display to be continuously calibrated for uniformity. You never have to worry about your image quality degrading.

**Talking color:** The colors are more true to life than anything you've ever seen and far surpass other digital display capabilities. Designed for color purity, Christie MicroTiles enable you to see your brand the way it should be. Christie MicroTiles utilize a color gamut that is unrivalled by today's technology. Your logo red - matched! If it's a brown logo - you won't have to settle for 'close enough!' Christie MicroTiles are your building block to brand integrity. Christie's advanced optics create a truly stunning image, combining an ideal balance of high brightness, deep contrast and unparalleled color range ideal for demanding indoor, high ambient light environments.

**Any viewpoint:** Your audience will consistently see what you want them to see, no matter where they're situated. In front, up close, on an angle, your content always looks great. Improve dwell time, ensuring your audience gets the full impact of your message.

**Resolution:** In this pixel powerhouse, you get 70x more pixels than the most popular 4mm surface-mount display LEDs. Your logo will never look blurred. Your art will always look flawless.

**Easy set-up:** Weighing in at only 20lbs (9.2kg) these lightweight tiles lock together quickly and easily, your only limitation being your imagination. Create any conceivable shape in a snap.

**Low operating cost:** Each tile is 100% front accessible, allowing you to repair or replace any serviceable component in less than 15 minutes, without having to turn off or bring down any of the other tiles. Imagine also, 65,000 hours before Christie MicroTiles hit half brightness! With almost no downtime, your Christie MicroTiles display delivers the kind of long life and reliability ideal for generating ad revenue. Built on proven LED and DLP technology, Christie MicroTiles are built to last, maximizing your investment for years to come.





# CHRISTIE MICROTILES DESIGNER™

Some 'other' displays can be difficult to envision, specify and order. But with Christie MicroTiles Designer software, planning and visualizing a Christie MicroTiles installation can be done quickly and easily.

In a few steps you can see how your design will look in your space, create a simple reference diagram, and generate a bill of materials so that you can order everything that you need.

With an intuitive interface, the Designer software delivers a simulated visual representation of a Christie MicroTiles display in your environment. Simply import dimensions and an image of your intended display, add still or video content and watch as your environment comes to life with Christie MicroTiles. Move it around, add or remove tiles and the simulation changes as you manipulate the size and shape of your array.

Christie MicroTiles Designer even tells you the energy consumption of the display, how much it will weigh and shows you the optimal way to wire the tiles together. All these features ensure the system you get is the system you want and the system you need.

Christie MicroTiles Designer software will be available to download for free by logging on to [christiedigital.com/microtiles](http://christiedigital.com/microtiles).



# DESIGNING MADE EASY

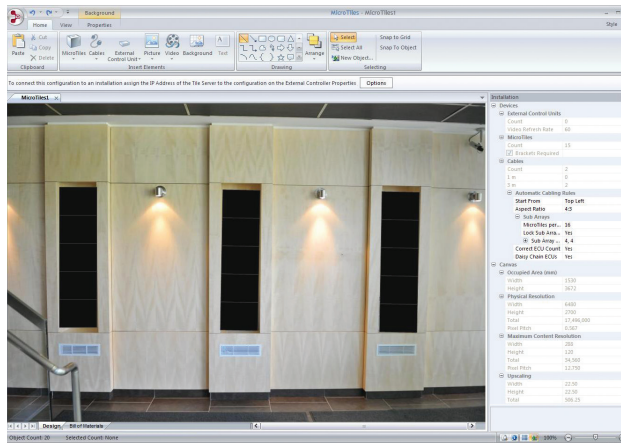

▲ Upload a sample image of the environment where you envision your display. Using the convenient user-friendly menu bar you can drop in 'sample' Christie MicroTiles into any environment and see what they will look like.

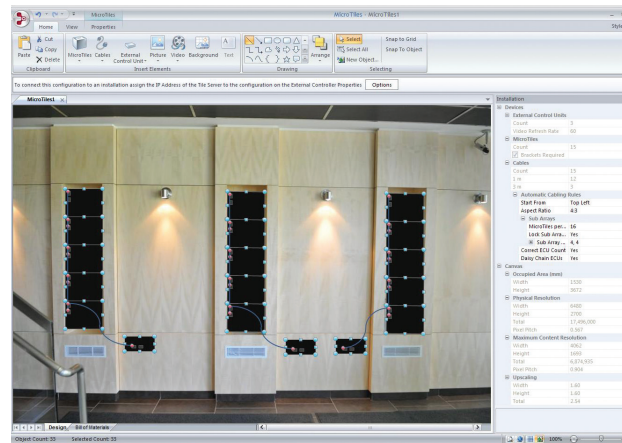

▲ Christie MicroTiles Designer tells you the energy consumption of the display, how much the total display will weigh and shows you the optimal way to wire the tiles together. All these features ensure the system you get is the system you want and the system you need.

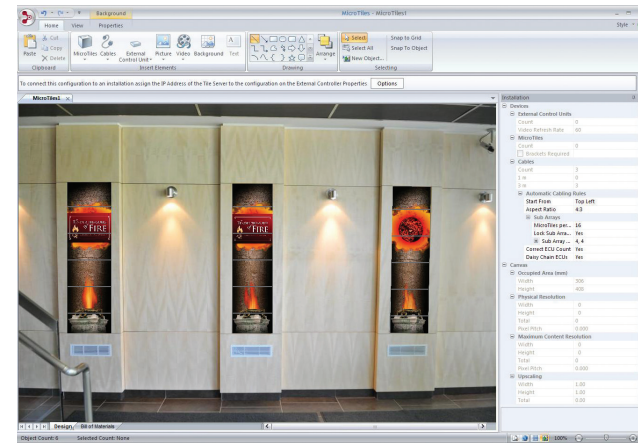

▲ Add still or video content and watch as your environment comes to life with Christie MicroTiles. Move it around, add or remove tiles and the simulation changes as you manipulate the size and shape of your array.

► Christie MicroTiles Designer even generates a bill of materials so you can order everything you need quickly and accurately. Your straightforward, easy-to-read bill of materials can be saved for future reference.

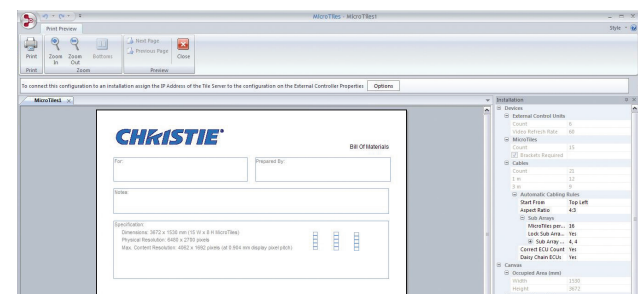





# CHRISTIE MICROTILES EXTERNAL CONTROL UNIT (ECU)

## THE POWER OF CONTROL

One of the greatest challenges faced by any modular display technology is the ability to control, match and monitor each discrete unit to ensure it works in harmony across the entire display. Christie addresses this challenge with the Christie MicroTiles ECU. Required for each Christie MicroTiles display, the ECU delivers content to the tiles while providing system level control, auto-calibration and monitoring of the full display. Simple, small and affordable, the ECU is compatible with all standard graphic formats, playback devices and mainstream creative and digital signage software.

**Easily display content:** To play video or data on the tiles, simply connect a PC or other media player to the ECU using the single-link DVI connection provided. If your PC or other media player has multiple video outputs, simply connect each output to a separate ECU. The ECUs work together to balance color and brightness automatically.

**Color and brightness auto-calibration:** Unlike other solutions that require painstaking manual fine-tuning during set-up and over the lifetime of the display, the ECU monitors the status and performance of each tile, and automatically calibrates color and brightness across the entire display in real-time. Sensors within each tile continuously monitor the performance of each LED independently, and this information

is reported to the ECU every few seconds. The ECU then adjusts all the tiles in real-time to a common color space and brightness level. And, even if a light engine is entirely replaced in one of the tiles, the system will adapt automatically to ensure the display is evenly matched. In configurations where more than one ECU is used, the ECUs communicate with each other to perform these adjustments.

**Choice of resolution:** Each ECU can drive hundreds of tiles, and more than 100 ECUs can be connected to a single array, allowing you to achieve almost any resolution imaginable. In a more complex set-up, you may wish to have multiple ECUs. The ECU will detect this and arbitrate to a single master controller, with any other ECUs in the network acting as slaves.

As a rule of thumb, six tiles per ECU can support native resolution. However, Christie MicroTiles have outstanding scaling technology built-in. In many cases, this enables you to lower your system costs, while maintaining superb image quality... the choice is yours.

**Simple interface:** By connecting to the ECU locally or remotely via Ethernet, the display can be controlled through an intuitive web interface. In addition, a radio frequency remote control can be used to navigate menu commands on the On-Screen Display from up to 100m (328ft) away.





## REMOTE MANAGEMENT, MONITORING AND CONTROL

Whether you have one display or hundreds, Christie offers the choice of remote management, monitoring and control services. Many organizations have their own solution for display management and control. For those who prefer another solution, our Christie Managed Services\* team offers a portfolio of proven and reliable services - all designed and customized to meet the unique needs of your organization or signage network.

Like many of the Fortune 1000 companies that rely on Christie Managed Services to

monitor their digital assets and devices, you don't need to invest in development resources to manage or sustain your business. Christie acts as an extension of your own expertise. We bring our AV/IT industry know-how, qualified local field technicians, a national footprint and a commitment to drive a project through to completion to fully support your programs.

A partnership with Christie Managed Services puts the control of your assets where it belongs - with you.

\*Christie Managed Services is offered in the continental United States and Canada. For services in other regions, Christie partners with the leading professional services organizations to provide remote management, control and monitoring of your assets.

## INDIVIDUAL DISPLAYS OR MEGA-PIXEL WALLS

Christie MicroTiles are designed to work with leading playback systems and video processors - ensuring that you can choose the media player, scheduler and video processor that's just right for your business.

When your design calls for a mega-pixel wall with multiple sources that need to be managed and controlled, Christie has the solution for you. Chosen by the world's foremost broadcasters, event producers and designers, the popular

Christie Vista series of video processors and universal routing switchers provide the ultimate freedom to accept any source format, convert it, and send it to any output display. With the Christie Vista URS, source content is processed while being routed and most or all of your front- and back-end boxes are eliminated - reducing your requirements for processing down to one piece of equipment and one point of control.



# 1

## When color matters

Christie MicroTiles offer you color reproduction capability that is a full 115% of the NTSC color gamut and exceeds standard LCD flat panels by over 50%. When you need a specific red, it delivers that red; brown - no longer a challenge. Maintain creative intent, your brand integrity and your vision by utilizing Christie MicroTiles.

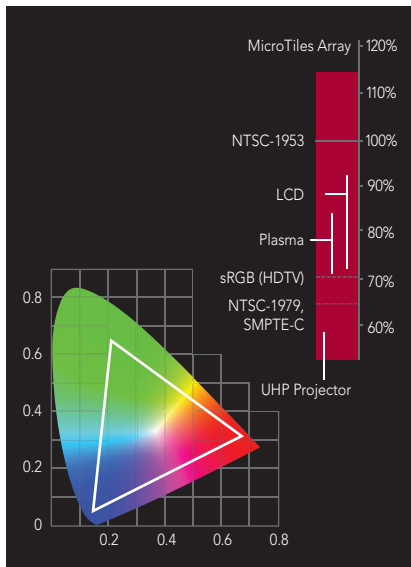

Christie MicroTiles color gamut

# 2

## Higher resolution

In this pixel powerhouse, you get 70x more pixels than the most popular 4mm surface-mount display LEDs. Your logo will never look blurred. Your art will always look flawless. Your geographical content will never be misleading. And your message will be seen.

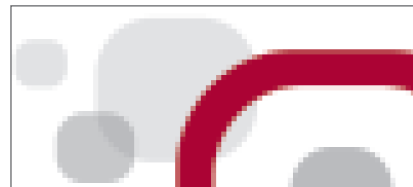

Best LED



60" High Definition LCD/Plasma



Christie MicroTiles

# 3

## Any shape, any size

Limited only by your imagination, Christie MicroTiles can be configured in any shape and any size. See your ideas come to life, wherever, whenever and however you want.



Strips

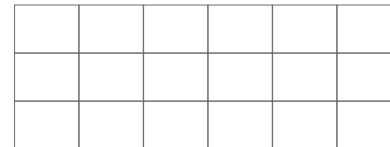

Mega pixel walls - Concave possible



Columns

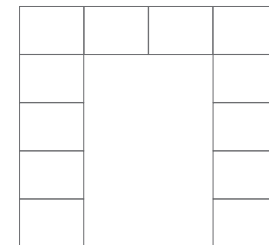

Arches

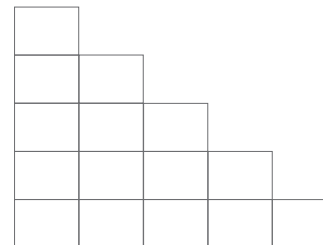

Stairs

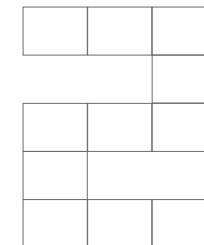

Snakes

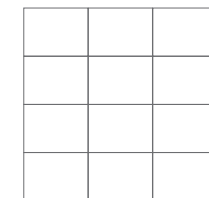

Squares

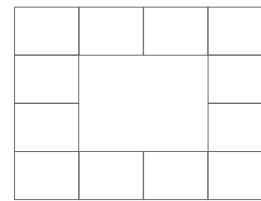

Retail displays - Product in center display

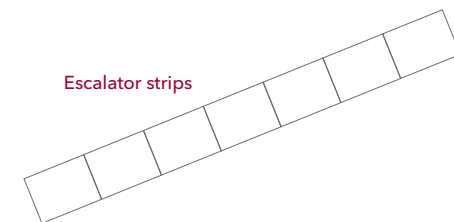

Escalator strips



Snap, lock  
and play

4

Lightweight, modular tiles lock together quickly and easily like building blocks. Sit back while the tiles automatically detect each other and display an image on the screen. Tear them down, reconfigure them and they'll still automatically recognize each other.

Long  
lasting  
reliability

5

Reliable solid-state components, including LEDs rated at 65,000 hours to half brightness, means no lamps or consumables to replace for more than 7 years! With Christie MicroTiles, you can be assured your message will be displayed reliably and consistently, just as you envisioned.

Automatic  
color and  
brightness  
matching

6

These visual building blocks have built-in sensors that monitor each LEDs performance, allowing the system to detect each other in the array, and automatically adjust brightness and color during set-up and continuously over the life of your display.

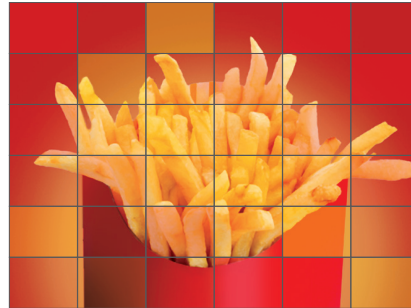

Uncalibrated

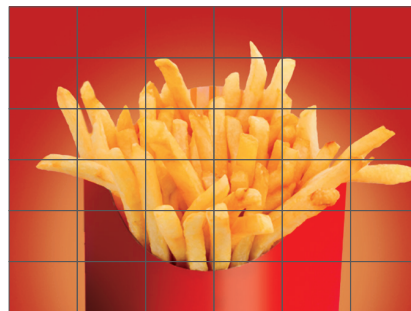

Calibrated

No pixel  
left behind

7

With the ultra-thin seam between tiles, you can be assured that all the information you need is visible, with no important content left behind.

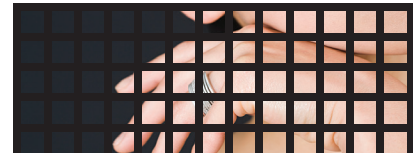

Best LED - ~1mm every ~3mm

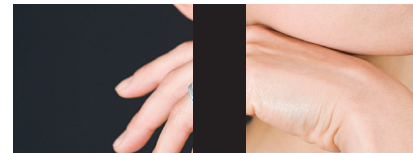

Best LCD - ~7mm

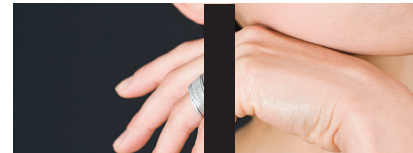

Best Plasma - ~4mm



Christie MicroTiles - ~1mm

Easy to  
service

8

Each tile is 100% front accessible, allowing you to repair or replace any serviceable component in less than 15 minutes, without having to turn off or bring down any of the other tiles.



A handy suction cup provides quick and easy access to any tile in an array.



## THE GREENER CHOICE

Christie is on the leading edge of greener solutions in this industry. That's why we've created a product with no consumables. No consumables are a big deal in today's environment. We're RoHS compliant and have built-in eco-power consumption modes. Christie MicroTiles are an ideal choice for LEED projects, and for any building where environmental standards must be met.



Christie won the Green AV Award at the inaugural 2010 InfoComm 100 conference. The Green AV Award recognizes organizations for their commitment to social responsibility, sustainability and the environment.



▲ Lightweight and shallow rear projection modules can be scaled to any size, shape and orientation, forming a digital canvas with minimal 1mm seams.



▲ Our radio frequency remote control can be used to navigate menu commands on the On-Screen Display from up to 100m (328ft) away.

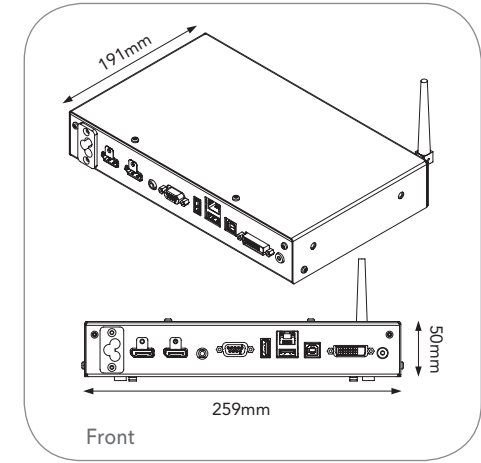

▲ To play video or data on the tiles, simply connect a PC or other media player to the ECU using the single-link DVI connection provided. If your content exceeds the limit for DVI (i.e. approximately WUXGA at 60Hz), simply increase the number of ECUs connected to the display.

## CHRISTIE MICROTILES SCREENS

To ensure your Christie MicroTiles display provides the best possible image quality for your application we offer two screen options. The S100 screen is a high gain, high brightness screen that provides vivid life-like colors. The S200 screen is a lower gain screen with improved uniformity at all viewing angles. Whether you're up close or far away, images remain clear and sharp with either screen.

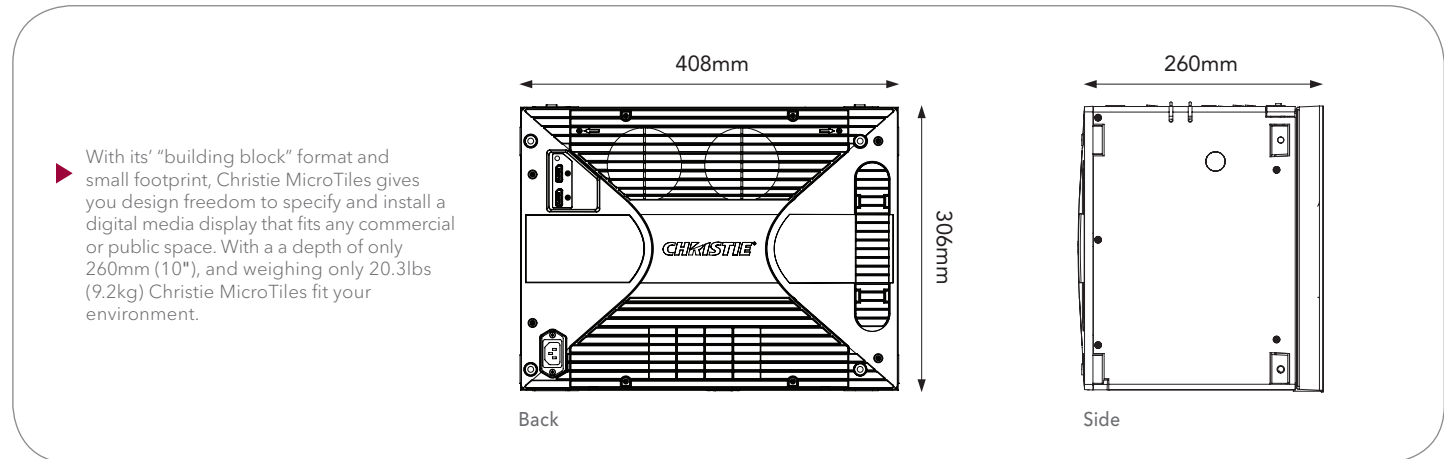

▶ With its "building block" format and small footprint, Christie MicroTiles gives you design freedom to specify and install a digital media display that fits any commercial or public space. With a depth of only 260mm (10"), and weighing only 20.3lbs (9.2kg) Christie MicroTiles fit your environment.



Technical specifications			
Model numbers	display unit	• D100	
	screens	• S100 • S200	
	external control unit (ECU)	• E100	
Physical specifications	Display unit with screen		ECU
	height	• 306mm (12.05")	• 50mm (1.97")
	width	• 408mm (16.06")	• 259mm (10.20")
	depth	• 260mm (10.24")	• 191mm (7.52")
	weight	• 9.2kg (20.3lbs)	• 1.6kg (3.5lbs)
Display specifications	screen size (diagonal)	• 510mm (20")	
	native resolution per tile	• 720 x 540	
	pixel pitch	• 0.567 x 0.567mm	
	screen gap	• 1.3mm typical at 25°C (77°F) ambient	
	maximum calibrated brightness	• 800 nits (cd/m <sup>2</sup> )	
	LED lifespan (50% brightness)	• 65,000 hours	
	peak white color temperature	• 6500K	
	adjustable gamma	• Yes	
	color space (CIE 1931)	• 115%	
	optical system	• DLP® 0.55" SVGA	
Screen specifications	S100		S200
	maximum calibrated brightness	• 800 nits	• 400 nits
	operating temperature	• 5°C (41°F) minimum • 40°C (104°F) maximum	• 17°C (63°F) minimum • 31°C (88°F) maximum
	storage temperature	• -20°C (-4°F) minimum • 50°C (122°F) maximum	• -20°C (-4°F) minimum • 31°C (88°F) maximum
	operating humidity	• 35-80% non-condensing	• 40-60% non-condensing
Processing and control	input signal compatibility	• Single-link DVI	
	processor bit rate	• 165M pixels per second	
	data link bit rate	• 5Gbps	
	color processing	• 13 bits	
	refresh rate	• 47-63Hz frame-locked	
	control interface	• Ethernet, USB 2.0, Serial	
Power	power supply	• AC 110V/220V, 50Hz/60Hz	
	power consumption per tile	• 70W typical	
	heat load per tile	• 239 BTUs/hr typical	
Operating specifications	clearance for ventilation (rear)	• 50mm (2") minimum	
	vibration/motion limit	• 0.5G	
	sound pressure per tile	• 35dB typical at 25°C (77°F) ambient	
	run time	• 24/7	
Accessories	• Mounting brackets for each tile above 5 high • Base feet for levelling the bottom row		
Regulatory approvals	• Directives (EC) 2002/95/EC (RoHS) • 2002/96/EC (WEEE) • Regulation (EC) No. 1907/2006 (REACH) • CAN/CSA C22.2 No. 60950-1-03 2nd Edition • UL 60950-1, 2nd Edition • IEC 60950-1:2001, 2nd Edition • FCC, Part 15, Subpart B, Class A • EN55022/CISPR22 Class A • EN55024 / CISPR24 • CE (EU) • GoST-R (Russia) • KC/KCC (Korea) • PSE (Japan) • C-Tick (Australia & New Zealand) • Singapore • Dubai		
Limited warranty	• 2 years parts and labor • Contact an authorized Christie representative for full details of our limited warranty		

\* All specifications are based on a typical canvas of Christie Micro-Tiles operating at maximum brightness with color and brightness matching enabled. For more detailed specifications across a broader range of operating conditions, please refer to the User Manual.

#### Corporate offices

**Christie Digital Systems USA, Inc**  
USA – Cypress  
PH: 714 236 8610

**Christie Digital Systems Canada Inc.**  
Canada – Kitchener  
PH: 519 744 8005

#### EMEA offices

**United Kingdom**  
EMEA Regional Head Office  
ViewPoint  
200 Ashville Way  
Wokingham  
Berkshire, U.K.  
RG41 2PL  
PH: +44 (0) 118 977 8000

**Africa**  
PH: +27 (0)11 510 0094

**Eastern Europe**  
Representative Office  
PH: +36 (0)1 47 48 100

**France**  
PH: +33 (0) 1 41 21 44 04

**Germany**  
PH: +49 2161 664540

**Middle East**  
PH: +971 (0) 4 320 6688

**Spain**  
PH: +34 91 633 9990

**Italy**  
Independent Sales Consultant Office  
PH: +39 (0) 2 9902 1161

**Russia**  
Independent Sales Consultant Office  
PH: +7 (495) 930-8961



 **For the most current specification information, please visit [www.christieemea.com](http://www.christieemea.com)**

Copyright 2014 Christie Digital Systems USA, Inc. All rights reserved. All brand names and product names are trademarks, registered trademarks or tradenames of their respective holders. Christie Digital Systems Canada Inc.'s management system is registered to ISO 9001 and ISO 14001. Performance specifications are typical. Due to constant research, specifications are subject to change without notice.  
CHRI2851\_EN\_JAN14

**CHRISTIE®**