The top half of the page features a complex, abstract background of overlapping, semi-transparent blue triangles and polygons in various shades of blue, creating a dynamic, crystalline effect. This pattern transitions into a clean white background at the bottom.

User Guide
020-102993-06

Mirage SST

CHRISTIE®

NOTICES

COPYRIGHT AND TRADEMARKS

Copyright © 2021 Christie Digital Systems USA Inc. All rights reserved.

All brand names and product names are trademarks, registered trademarks or trade names of their respective holders.

GENERAL

Every effort has been made to ensure accuracy, however in some cases changes in the products or availability could occur which may not be reflected in this document. Christie reserves the right to make changes to specifications at any time without notice. Performance specifications are typical, but may vary depending on conditions beyond Christie's control such as maintenance of the product in proper working conditions. Performance specifications are based on information available at the time of printing. Christie makes no warranty of any kind with regard to this material, including, but not limited to, implied warranties of fitness for a particular purpose. Christie will not be liable for errors contained herein or for incidental or consequential damages in connection with the performance or use of this material. Manufacturing facilities in Canada and China are ISO 9001 certified.

For the most current technical documentation and office contact information, visit <http://www.christiedigital.com>.

Warranty

Products are warranted under Christie's standard limited warranty, the details of which are available at <https://www.christiedigital.com/help-center/warranties/> or by contacting your Christie dealer or Christie.

PREVENTATIVE MAINTENANCE

Preventative maintenance is an important part of the continued and proper operation of your product. Failure to perform maintenance as required, and in accordance with the maintenance schedule specified by Christie, will void the warranty.

REGULATORY

The product has been tested and found to comply with the limits for a Class A digital device, pursuant to Part 15 of the FCC Rules. These limits are designed to provide reasonable protection against harmful interference when the product is operated in a commercial environment. The product generates, uses, and can radiate radio frequency energy and, if not installed and used in accordance with the instruction manual, may cause harmful interference to radio communications. Operation of the product in a residential area is likely to cause harmful interference in which case the user will be required to correct the interference at the user's own expense. Changes or modifications not expressly approved by the party responsible for compliance could void the user's authority to operate the equipment

CAN ICES-3 (A) / NMB-3 (A)

이 기기는 업무용(A급)으로 전자파적합등록을 한 기기이오니 판매자 또는 사용자는 이점을 주의하시기 바라며, 가정 외의 지역에서 사용하는 것을 목적으로 합니다.

ENVIRONMENTAL



The product is designed and manufactured with high-quality materials and components that can be recycled and reused. This symbol  means that electrical and electronic equipment, at their end-of-life, should be disposed of separately from regular waste. Please dispose of the product appropriately and according to local regulations. In the European Union, there are separate collection systems for used electrical and electronic products. Please help us to conserve the environment we live in!

Content

Introduction	7
Third-party products.	7
Important safeguards.	7
Safety and warning guidelines.	7
Laser safety precautions.	8
Light intensity hazard distance.	9
Product documentation.	10
Related documentation.	10
Technical support.	11
Projector overview.	11
Contact your dealer.	11
Key features.	12
How the projector works.	12
List of components.	13
Display panel components.	13
IR/wired remote keypad.	15
Operating the projector	17
Performing initial system start-up.	17
Turning on the system.	19
Turning off the projector.	21
Projector LED status indicators.	22
Projector LED shutter indicators.	22
Adjusting the image	23
Selecting screen image orientation.	23
Setting the image resize preset.	23
Adjusting lens settings.	23
Adjusting offset.	23
Resetting the lens to home position.	24
Aligning the image with lens zoom and focus.	24
Locking the lens motor.	24
Calibrating the zoom motor.	24
Determining what lens warnings are displayed.	25

Lens control limitations.	25
Ultra short throw lens control limitations.	27
Adjusting primary colors.	28
DMD color correction.	28
Adjusting color by precise chromaticity values.	28
Adjusting color by saturation.	29
Signal color correction.	29
Adjusting the color space.	29
Adjusting color by temperature.	29
Selecting the color correction mode.	30
Correcting for ambient light.	30
Setting the frame delay.	30
Enabling film mode detect.	30
Adjusting the image sharpness.	31
Creating a seamless image with edge blending.	31
Adding edge blends to the projector.	31
Enabling basic edge blending.	31
Resetting edge blending.	32
Geometry correction.	32
Enabling warping.	32
Correcting the shape of a keystone image.	32
Configuring system settings.	35
Setting the date.	35
Setting the time.	35
Changing the splash screen.	35
Determining the on-screen display position.	35
Changing the language.	36
Changing the temperature units.	36
Changing the user account password.	36
Accessing the generated user account password.	36
Turning on the projector with low voltage.	37
Resuming projector operation after an AC power interruption.	37
Keeping electronics on in standby mode.	37
Enabling direct pass-through of HDMI, 3G, and DisplayPort input signals.	37
Configuring video input.	38
Disabling secondary DVI receivers.	38
Informing the source of signal preferences.	38
Christie high frame rate.	38

Required components.	39
Video sources.	39
Enabling or disabling the high frame rate (HFR).	40
Selecting the high frame rate EDID.	40
Configuring the laser power settings.	40
Setting up 1D color uniformity.	41
Determining shutter operation during projector on sequence.	43
Configuring communications.	44
Enabling projector communication.	44
Setting the remote access level.	44
Communicating with Mirage SST through Art-Net.	45
Art-Net channel listing.	45
Index list for the input channel.	47
Working with macros.	48
Adding a Scheduled Event macro.	49
Copying a macro.	49
Editing a macro.	50
Deleting a macro.	50
Configuring the GPIO.	50
GPIO connector.	51
Setting up projector profiles.	53
Creating a new projector profile.	53
Importing a projector profile.	53
Restoring settings from a profile.	53
Renaming a projector profile.	54
Exporting a projector profile to an external device.	54
Deleting a projector profile.	54
Setting up Christie View.	55
Required components.	55
Adding the Mirage Pro software license to the projector.	56
Setting up Christie View.	56
Setting up the glasses.	57
Connection diagrams.	58
Troubleshooting.	59
Backing up, restoring, and upgrading files.	61

Upgrading the Mirage SST software.	61
Adding a software license to a projector.	61
Exporting backup settings to an external device.	62
Importing a file from an external device to restore settings.	62
Restoring projector default settings.	63
Diagnostic tools	64
Viewing Mirage SST information.	64
Freezing an image.	64
Test patterns.	64
Selecting a test pattern.	64
Modifying grey level test pattern characteristics.	65
Modifying ramp test pattern characteristics.	65
Modifying grid test pattern characteristics.	65
Enabling a specific test pattern color.	66
Selecting an engine test pattern.	66
Viewing Mirage SST status.	66
Running the Mirage SST interrogator.	66
Identifying where alarm and trap messages are sent.	67
Setting the SNMP read community string.	67
Configuring traps.	67
Defining a trap IP address.	67
Downloading the SNMP MIB files.	68
Restoring factory default settings.	68
Regulatory.	69
Safety.	69
Electro-magnetic compatibility.	69
Emissions.	69
Immunity.	69
Environmental.	69

Introduction

This manual is intended for professionally trained operators of Christie high-brightness projection systems.



The illustrations in this document are for representation only and may not depict your projector model exactly.

Only Christie qualified technicians who are knowledgeable about the hazards associated with laser use, high-voltage, and the high temperatures generated by the projector lasers are authorized to assemble, install, and service the projector.

For complete Mirage SST product documentation and technical support, go to www.christiedigital.com.

Third-party products

This projector is certified to work only with certain specified third-party components. Use only Christie approved third-party components with the projector. Using non-approved components with the projector can lead to potential safety hazards and void the projector warranty.

For detailed safety information on third-party components, refer to the product documentation provided by the manufacturer of the component.

Important safeguards

To prevent personal injury and to protect the device from damage, read and follow these safety precautions. This projector is intended for use in a non-cinema environment.

Safety and warning guidelines

Read all safety and warning guidelines before installing or operating the projector.

This projector is intended for use in a fixed install environment (also known as a cinema environment).

This projector must be operated in an environment that meets the operating range specification. Use only the attachments and/or accessories recommended by Christie. Use of others may result in the risk of fire, shock, or personal injury.



Warning! If not avoided, the following could result in death or serious injury.

- This product must be operated in an environment that meets the operating range as specified in this document.
- Do not look directly into the lens when the light source is on. The extremely high brightness can cause permanent eye damage.
- ELECTRICAL and BURN HAZARD! Use caution when accessing internal components.
- FIRE HAZARD! Keep hands, clothes, and all combustible material away from the concentrated light beam of the projector.
- Keep fingers and other body parts away from the moving parts in the product. Tie back long hair, and remove jewelry and loose clothing before manually adjusting the product.
- FIRE AND SHOCK HAZARD! Use only the attachments, accessories, tools, and replacement parts specified by Christie.
- Do not operate the product without a lens installed.
- Always use a lens plug when installing or moving the product. This prevents contaminants from entering the product.
- FIRE AND SHOCK HAZARD! Use only the attachments, accessories, tools, and replacement parts specified by Christie.



Caution! If not avoided, the following could result in minor or moderate injury.

- TRIP OR FIRE HAZARD! Position all cables where they cannot contact hot surfaces, be pulled, be tripped over, or damaged by persons walking on or objects rolling over the cables.

Laser safety precautions

Read all safety and warning guidelines before operating the projector laser.



Warning! If not avoided, the following could result in death or serious injury.

- LASER RADIATION HAZARD! This projector has an external Class 4 laser module. Never attempt to disassemble or modify the laser module.
- Possible hazardous optical radiation emitted from this product. (Risk group 3)
- Only Christie qualified technicians who are knowledgeable about the hazards associated with laser use, high-voltage, and high temperatures generated by the product are authorized to assemble, install, and service the Christie Laser Projection System.
- RADIATION HAZARD! Use of controls or adjustments, or performing procedures other than those specified may result in hazardous radiation exposure.
- Do not look directly into the lens when the light source is on. The extremely high brightness can cause permanent eye damage.
- Do not operate the product without all of its covers in place.
- LASER RADIATION! Do not short the contact rings.
- Always keep a protective cap on disconnected fiber optic cables.

Light intensity hazard distance

This projector has been classified as Risk Group 3 as per the IEC 62471-5:2015 standard due to possible hazardous optical and thermal radiation being emitted.



Warning! If not avoided, the following could result in serious injury.

- PERMANENT/TEMPORARY BLINDNESS HAZARD! No direct exposure to the beam must be permitted. Class 1 Laser Product - Risk Group 3 according to IEC 60825-1:2014 and IEC 62471-5:2015.
- PERMANENT/TEMPORARY BLINDNESS HAZARD! Operators must control access to the beam within the hazard distance or install the product at the height that prevents exposure of spectators' eyes within the hazard distance. The hazard zone must be no lower than 2.5 meters (US installations) or 2.0 meters (global installations) above any surface upon which any persons are permitted to stand and the horizontal clearance to the hazard zone must be a minimum 1.0 meters.
- EXTREME BRIGHTNESS! Do not place reflective objects in the product light path.

The following show the zones for ocular and skin hazard distances.

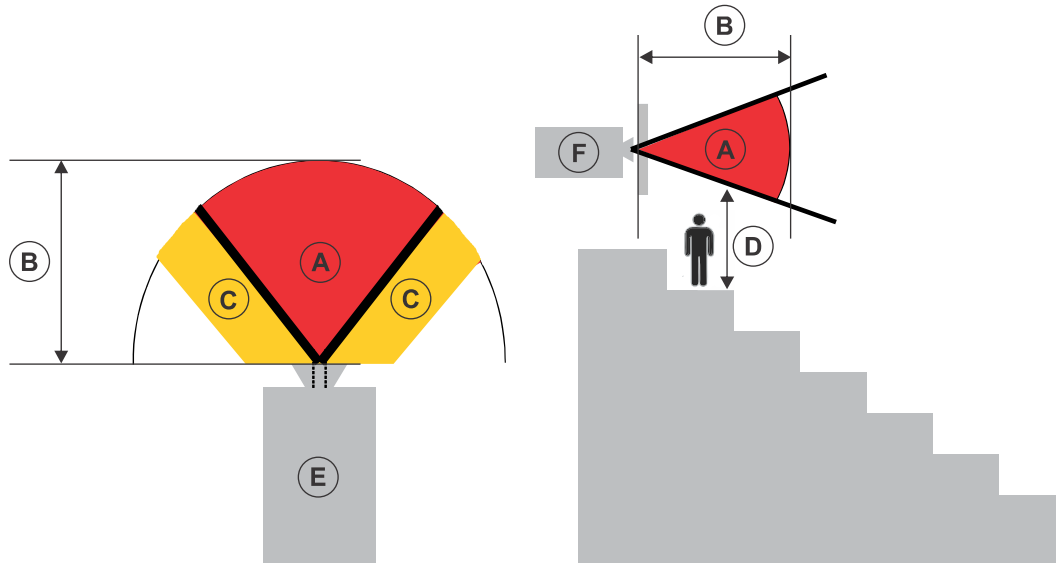

- A—Hazard zone. The region of space where the projection light from the laser-illuminated projector is above emission limits for Risk Group 2. The light intensity may cause eye damage after a momentary or brief exposure (before a person can avert his or her eyes away from the light source). The light may cause skin burns to occur.
- B—Hazard distance. Operators must control access to the beam within the hazard distance or install the product preventing potential exposure of the spectators' eyes from being in the hazard distance.
- C—No access zone. Horizontal clearance of the no access zone must be a minimum of 1.0 meters.
- D—Vertical distance to hazard zone. The hazard zone must be no lower than 2.5 meters (US installations) or 2.0 meters (global installations) above any surface upon which any persons are permitted to stand.

If the vertical distance to hazard zone requirement (Zone D) is satisfied, the horizontal clearance distance (Zone C) is not needed.

- E—Represents the top view of the projector.
- F—Represents the side view of the projector.

For information detailing the hazard distance for each lens, refer to the *Mirage SST Installation and Setup Guide* (P/N: 020-102956-XX).

For Installations in the United States

The following must be in place for laser-illuminated projector installations in the United States:

- Permanent show installations containing Risk Group 3 laser-illuminated projectors must meet the following conditions:
 - Installed by Christie or by Christie-authorized and trained installers. Refer to the EXTERNAL - Laser safety awareness training (Course code: CS-ELSA-01) on the <http://www.christieuniversity.com> site.
 - Performed according to instructions provided by Christie.
 - Ensure the projection system is securely mounted or immobilized to prevent unintended movement or misalignment of the projections.
- The projection room shall be clearly identified by the posting of laser warning and restricted access signs. The projection room sign must display the warning "Class 1 Risk Group 3 Laser Controlled Area No Direct Exposure to Beam Shall be Permitted".
- The Christie Laser Projection System Installation Checklist must be fully completed after the installation and sent to lasercompliance@christiedigital.com. A copy can remain on-site. This checklist can be found as a separate document in the accessory box with the manual.
- Certain US states have additional laser regulatory requirements. Contact lasercompliance@christiedigital.com for additional regulatory requirements.

Product documentation

For installation, setup, and user information, see the product documentation available on the Christie website. Read all instructions before using or servicing this product.

1. Access the documentation from the Christie website:
 - Go to this URL: <http://bit.ly/2TI2aEW> or <https://www.christiedigital.com/en-us/3d/products-and-solutions/projectors/mirage-sst>.
 - Scan the QR code using a QR code reader app on a smartphone or tablet.

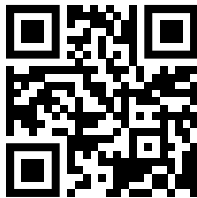

2. On the product page, switch to the **Downloads** tab.

Related documentation

Additional information on this product is available in the following documents.

- *Mirage SST Product Safety Guide* (P/N: 020-102992-XX)

- *Mirage SST Installation and Setup Guide (P/N: 020-102956-XX)*
- *Mirage SST Projector Head Specifications Guide (P/N: 020-102994-XX)*
- *Mirage SST Status System Guide (P/N: 020-103007-XX)*
- *Mirage SST Serial Commands Guide (P/N: 020-103005-XX)*
- *Mirage SST Projector Head Service Guide (P/N: 020-103039-XX)*

Technical support

Technical support for Christie Enterprise products is available at:

- North and South America: +1-800-221-8025 or Support.Americas@christiedigital.com
- Europe, Middle East, and Africa: +44 (0) 1189 778111 or Support.EMEA@christiedigital.com
- Asia Pacific (support.apac@christiedigital.com):
 - Australia: +61 (0)7 3624 4888 or tech-Australia@christiedigital.com
 - China: +86 10 6561 0240 or tech-supportChina@christiedigital.com
 - India: +91 (80) 6708 9999 or tech-India@christiedigital.com
 - Japan: 81-3-3599-7481
 - Singapore: +65 6877-8737 or tech-Singapore@christiedigital.com
 - South Korea: +82 2 702 1601 or tech-Korea@christiedigital.com
- Christie Professional Services: +1-800-550-3061 or NOC@christiedigital.com

Projector overview

Learn about the Mirage SST projectors.

Mirage SST are professional quality projectors using Digital Light Processing (DLP™) technology from Texas Instruments. Mirage SST are engineered specifically for complex, high-end applications like planetariums, dome theaters, and theme park attractions to offer stunning wide screen, high resolution 4K images up to 120 frames (for Mirage SST) per second.

The systems can be 3P (single) or 6P (dual).

Mirage SST provide several design and installation advantages. Their small form factor allows them to be installed independently, or as part of a multi-projector array, into tight, challenging environments. Both single (3P) and dual (6P) systems are available. The remote light source also allows the chilling equipment to be located away from the projector head where its noise will not impact the audience's enjoyment of the show.

Contact your dealer

Record the information about your projector and keep this information with your records to assist with the servicing of your projector. If you encounter a problem with your Christie projector, contact your dealer.

Purchase record

Dealer:

Purchase record	
Dealer or Christie Sales/Service contact phone number:	
Projector serial number:	The serial number can be found on the license label located on the display panel
Purchase date:	
Installation date:	

Ethernet settings	
Default gateway:	
Projector IP address:	
Subnet mask:	

Key features

Understand the important features of the projector.

- Built in warp and blend of projected images
- Improved lens mount with bayonet style insertion
- Single phase 100-240 V
- Side access to optical adjustments
- 4K resolution for flexibility and future proofing
- Omnidirectional operation
- TruLife electronics
- LCD display to provide information at-a-glance

How the projector works

The Mirage SST accepts a variety of input signals for projection on front or rear projection screens, typical in commercial or other large screen applications.

High-brightness light is generated by a laser illumination source, then fed to the projector through a fiber optic cable, where it is modulated by three Digital Micromirror Device (DMD) panels responding to incoming data streams of digitized red, green and blue color information. Based on digital signals from the source, light from the responding on pixels of each panel is reflected, converged and then projected to the screen through a projection lens, where all pixel reflections are superimposed into a sharp full-color image.

The Mirage SST projector head provides all configuration and control for the laser illumination source. Never connect a laptop to the laser illumination source unless directed by Technical Support.

List of components

Verify all components were received with the projector.

- Power cord
- IR remote keypad
- Network cable
- Tools
- Fiber optic support
- Laser illumination source J33 terminal block 1 (P/N: 001-114198-XX)
- Fiber connector safety cover

Display panel components

Identify the main components of the display panel (also known as the home page).

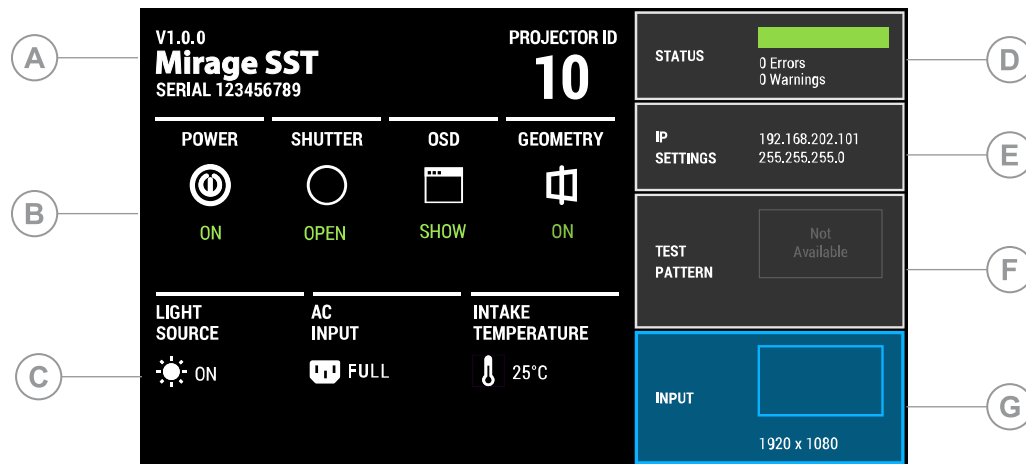

ID	Component	Description
A	Projector information	Provides information about the projector such as the projector name, serial number, software version, and projector ID.
B	Projector and Component Controls	Indicates the states of the projector and its components.
C	Power and Temperature	Indicates the light source mode, power mode, and intake temperature.
D	Status	Contains information about the health of the projector including the number of warnings and errors. Provides access to the status system.
E	IP Settings	Indicates the incoming voltage, measured in Volts, and intake temperature, measured in Celsius.
F	Test Pattern	Displays the currently selected test pattern. If no test pattern is selected, Off is displayed.

ID	Component	Description
		Provides access to the list of test patterns.
G	Input	Displays the signal for the currently selected input. Provides access to the list of input signals.

IR/wired remote keypad

The IR/wired remote keypad controls the projector by way of either wireless communications from a battery-powered infrared (IR) transmitter or a wired interface.

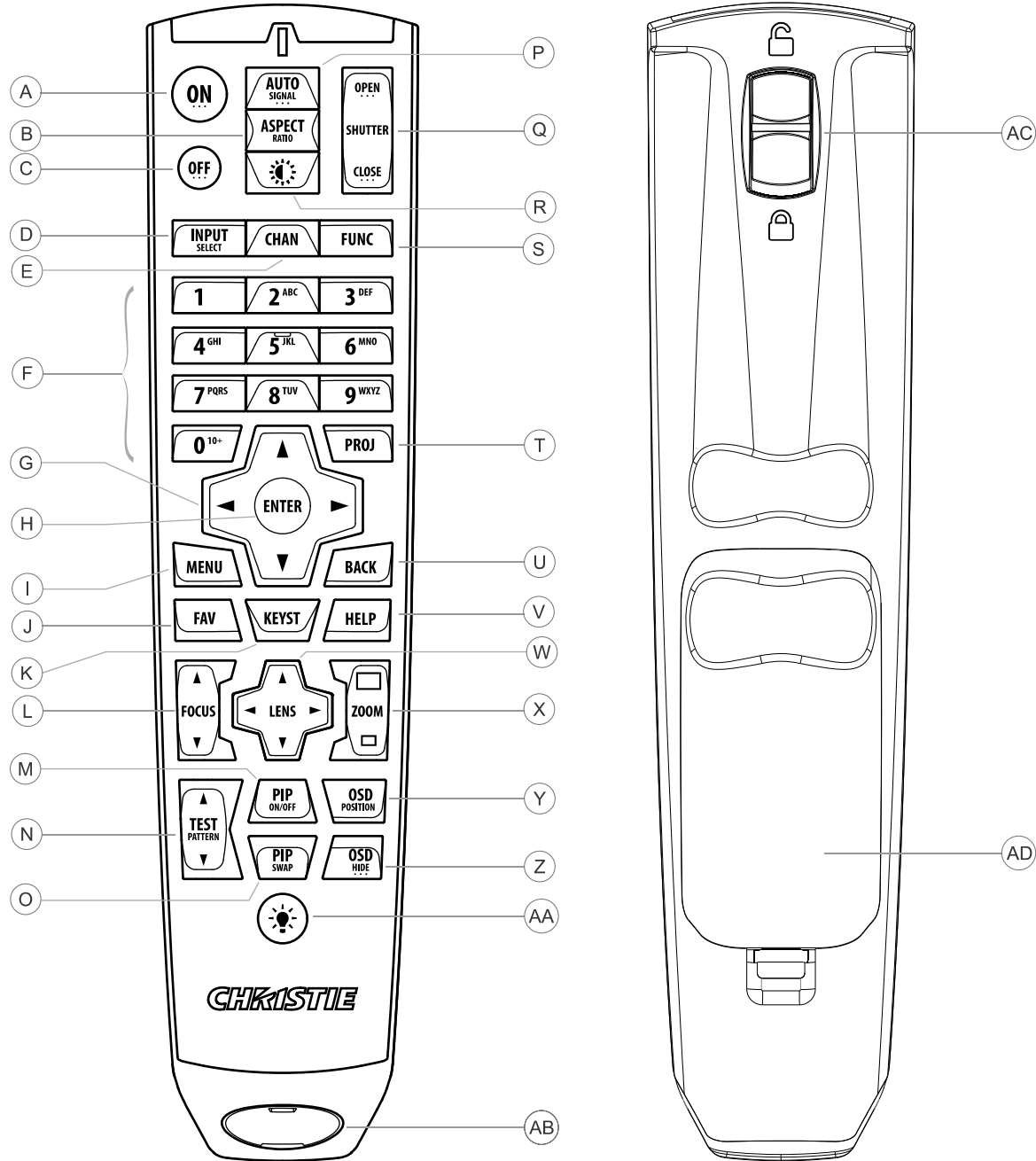

Button	Description
A	Powers on the projector light source.
B	Opens the aspect ratio dialog.

Button	Description
C	Turns off the light source and puts the projector in standby.
D	Selects an active or inactive input on any slot.
E	Not supported.
F	Enter a number, such as menu, item index or value.
G	Use the arrows to navigate within a menu or to adjust settings.
H	Selects a highlighted menu item and changes or accepts a value.
I	Toggles the menus on/off.
J	Not supported.
K	Opens the keystone dialog.
L	Adjusts the lens focus.
M	Not supported.
N	Displays a test pattern.
O	Not supported.
P	Optimizes the image automatically.
Q	Opens or closes the shutter.
R	Not supported.
S	Initiates a custom action when a number is selected.
T	Selects a projector in multi-projector installations.
U	Returns to the previous menu level or exits menus if at the top level.
V	Displays context-sensitive help.
W	Arrows adjust the lens offset.
X	Adjust the lens zoom.
Y	Opens the on-screen display position menu.
Z	Shows or hides the on-screen display menus.
AA	Turns the remote backlight on.
AB	Male 3-pin XLR connector for wired option.
AC	Lock/unlock the keypad.
AD	Battery door.

Operating the projector

Learn how to turn on and off the projector and the meaning of the status indicators.

Performing initial system start-up

Learn how to turn on all components of the Mirage SST system for the first time: chiller, laser illumination source, and projector head.



Warning! If not avoided, the following could result in death or serious injury.

- SHOCK HAZARD! Do not attempt operation if the AC supply is not within the specified voltage and current, as specified on the license label.

Never run the laser illumination source without the cooling system already running. The chiller must be the first item turned on before power is applied to the laser rack and kept operating until after the AC lockout/switch is rotated to the off position.

1. To be able to power on the laser illumination source using either the local or remote operation, ensure either the J33 terminal block 1 or terminal block 2 is installed.
For installation information, refer to the "Installing the J33 terminal block on the laser illumination source" topic in the Mirage SST Installation and Setup Guide (P/N: 020-102956-XX).
2. Verify the coolant lines are connected correctly.
3. Fill the chiller reservoir with an approved coolant.
4. Turn on the chiller, set the temperature to between 19°C (66°F) to 22°C (71.6°F).
For more information on how to turn on the chiller, refer to the chiller's product documentation.
5. Check the coolant level in the reservoir and hoses and top up the coolant as required.
6. Check that no leaks exist in the system.
7. Allow the chiller to run until the system is operating with no new bubbles entering the reservoir. Add additional coolant as necessary.
This typically takes approximately 5 to 10 minutes.
8. Power on the laser illumination source:
 - Local operation and the J33 terminal block 1 installed— Rotate the main AC lockout/switch (A) to the ON position and rotate the Power key (B) clockwise to the ON position.
 - Remote operation and the J33 terminal block 2 installed—Rotate the main AC lockout/switch (A) to the ON position and rotate the Power key (B) counter clockwise to the REM (remote) position. From the automation device, turn on the laser illumination source (by closing circuits 8/9 from the J33 wire).



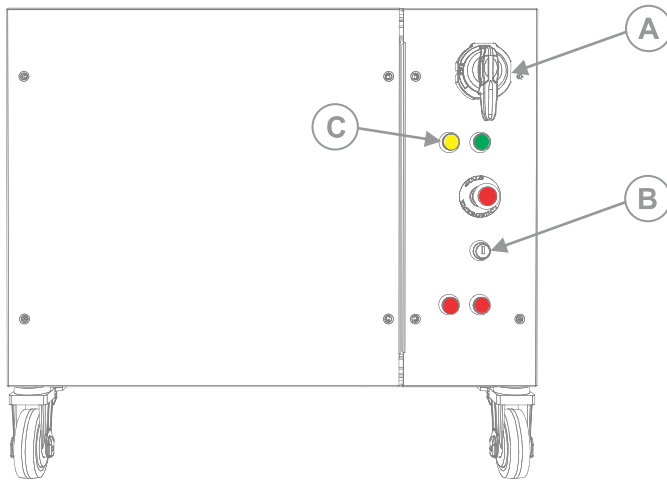

If using terminal block 2, ensure pins/wires 17 to 20 and 18 to 19 are closed or the projector will not operate when the key is in the ON or the remote (REM) position.

The Interlock status indicator (C) on the laser illumination source turns yellow.

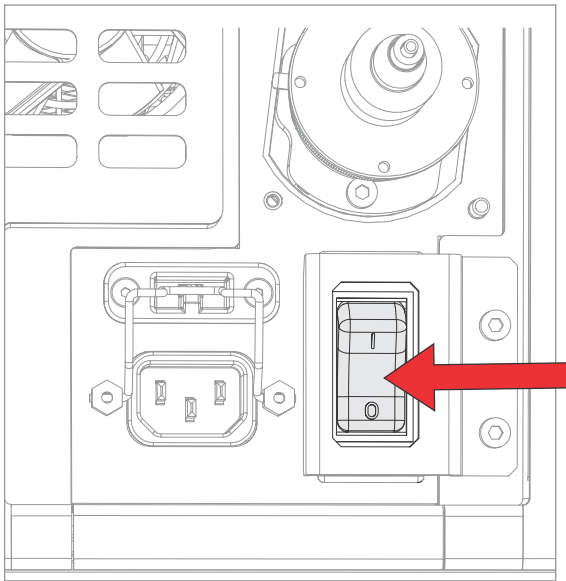

9. On the projector beside the AC inlet, move the AC breaker/switch to the ON position. The projector boots into standby mode after approximately 30 seconds. If the projector is properly connected, the light on the back of the projector should be yellow.



10. Once the projector is in standby, on the projector keypad or the projector remote, press and hold the power  button until you hear a beep. The projector can also be turned on using the web user interface. After a few seconds, the projector moves to the on state, causing the yellow light on the laser illumination source to turn off. The laser is ready to be turned on but no illumination occurs until the green button is pressed and the lasers have warmed up.
11. Turn on the lasers:
- Local operation and the J33 terminal block 1 installed— On the laser illumination source, press the green **Start** button (D). This illuminates the green (button) light and the yellow light goes out.
 - Remote operation and the J33 terminal block 2 installed—From the automation device, turn on the lasers with a 500ms contact closure of circuits 21/22 on the J33 wire. This illuminates the green (button) light and the yellow light goes out.

The two Emission status indicators (E) turn red. When the lasers are warmed up and the projector is ready, the shutter automatically opens and you can display an image (use test pattern if no source image is connected).

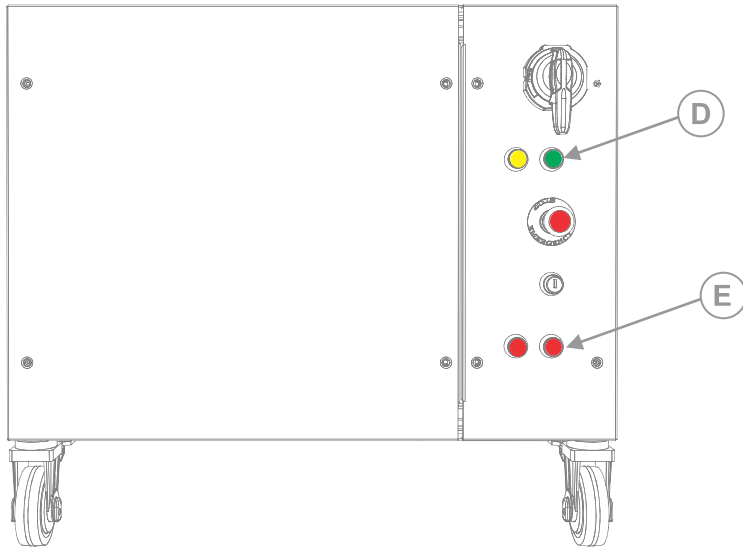

On the projector, the **Status > Laser Info > Laser Bank State** menu displays the message "Warming Up". When that message disappears, the lasers are ready. It typically takes the lasers approximately 10 to 15 minutes to warm up when turning on the first time from the off position. This could be longer if the start-up temperatures are approaching minimum or maximum temperatures for operation. The projector will operate with the shutter closed until the lasers are warmed up.

Turning on the system

After the system has been initiated for the first time, not all steps need to be performed when subsequently turning on the system.



Warning! If not avoided, the following could result in death or serious injury.

- SHOCK HAZARD! Do not attempt operation if the AC supply is not within the specified voltage and current, as specified on the license label.

Never run the laser illumination source without the cooling system already running. The chiller must be the first item turned on before power is applied to the laser rack and kept operating until after the AC lockout/switch is rotated to the off position.

1. Check the coolant level and if the coolant level is low, check for leaks.

It is expected to see periodic evaporation of the fluid in the system. Do one of the following:

- If no leak exists, **only** add distilled water (not drinking water).
- If a leak exists, after the leak is repaired, add premixed coolant at the recommended 2:1 ratio.



Never add premix coolant to a system that does not have a leak as only the water in the system evaporates over time. If coolant is added instead of distilled water, the correct concentration of the ratio of coolant to water (80/20) becomes too concentrated and overheating problems occur.

2. Turn on the chiller.

For more information on how to turn on the chiller, refer to the chiller's product documentation.

3. Turn on the laser illumination source: On the laser illumination source, rotate the main AC lockout/switch (A) to the on position and rotate the Power key (B) clockwise to the on position.
 - Local operation and the J33 terminal block 1 installed— Rotate the main AC lockout/switch (A) to the ON position and rotate the Power key (B) clockwise to the ON position.
 - Remote operation and the J33 terminal block 2 installed—Rotate the main AC lockout/switch (A) to the ON position and rotate the Power key (B) counter clockwise to the REM (remote) position. From the automation device, turn on the laser illumination source (by closing circuits 8/9 from the J33 wire).

The Interlock status indicator (C) on the laser illumination source turns yellow.

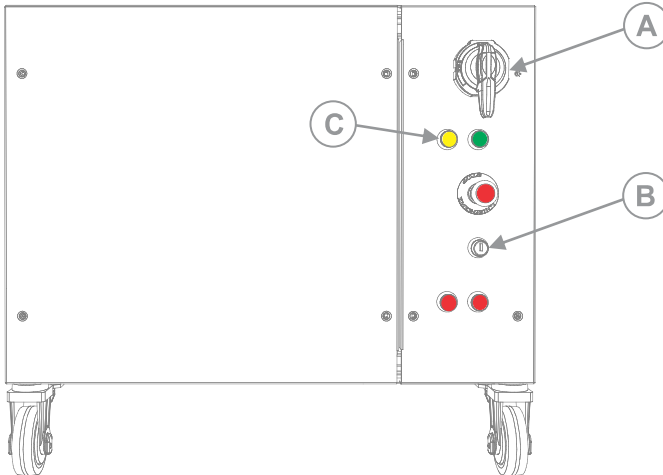

4. If the breaker is off, on the projector beside the AC inlet, move the AC breaker/switch to the on position.

The projector boots into standby mode after approximately 30 seconds.

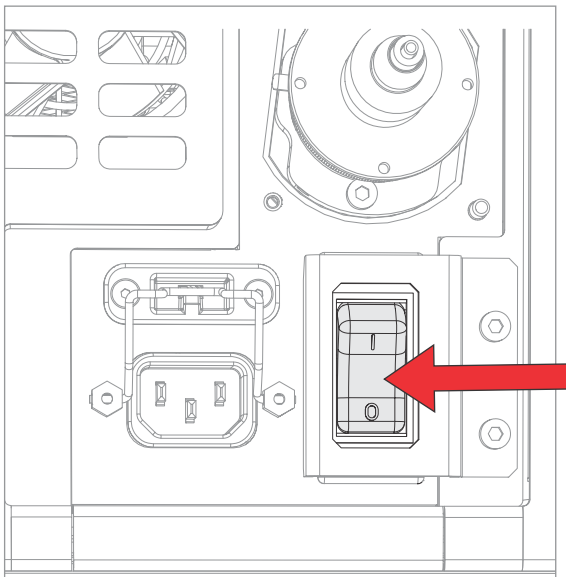

5. Once the projector is in standby, on the projector keypad or the projector remote, press and hold the power button (⏻) until you hear a beep.

The projector can also be turned on using the web user interface. After a few seconds, the projector moves to the on state, causing the yellow light on the laser illumination source to turn off. The laser is ready to be turned on but no illumination occurs until the green button is pressed and the lasers have warmed up.

6. Turn on the lasers:

- Local operation and the J33 terminal block 1 installed— On the laser illumination source, press the green **Start** button (D). This illuminates the green (button) light and the yellow light goes out.
- Remote operation and the J33 terminal block 2 installed—From the automation device, turn on the lasers with a 500ms contact closure of circuits 21/22 on the J33 wire. This illuminates the green (button) light and the yellow light goes out.

The two Emission status indicators (E) turn red. When the lasers are warmed up and the projector is ready, the shutter automatically opens and you can display an image (use test pattern if no source image is connected).

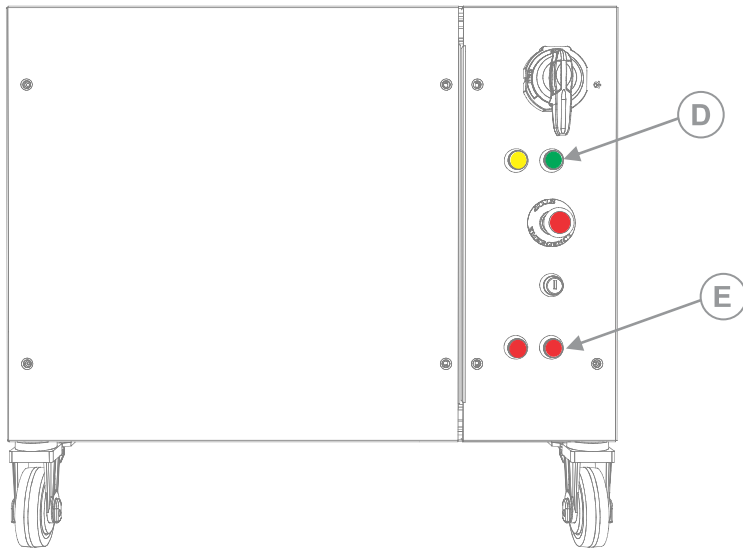

On the projector, the **Status > Laser Info > Laser Bank State** menu displays the message "Warming Up". When that message disappears, the lasers are ready. It typically takes the lasers approximately 10 to 15 minutes to warm up when turning on the first time from the off position. This could be longer if the start-up temperatures are approaching minimum or maximum temperatures for operation. The projector will operate with the shutter closed until the lasers are warmed up.

Turning off the projector

When powering off in preparation for inspection or maintenance, always disconnect from AC.

1. To turn the light source off using the projector keypad, press and hold the  button until you hear a beep.
To turn off the light source using the remote, press and hold the **OFF** button until you hear a beep.
When powering off the projector, allow the projector to complete its cool down cycle. Do not immediately unplug the projector if this can be avoided.
2. To turn off power to the projector, disconnect from AC power.

Projector LED status indicators

Identify the LED state colors and meaning.

LED	State		Description
Blue	Solid	Standby	Light source is off. Video electronics are off. Projector status is OK.
	Flashing	Cool down	Projector is moving to one of the two standby states: <ul style="list-style-type: none"> Light source is off and video electronics are booting up. Light source is off. Video electronics and light source is cooling down.
Green	Solid	Light source on	Light source is on. Projector status is OK.
	Flashing	Startup	Projector is moving to light source on state. Light source is warming up. Video electronics are initializing.
Yellow	Solid	Warning in standby	Projector is in standby state. A problem exists with the projector that does not prevent it from operating.
	Flashing yellow/green	Warning during startup	Projector is in a startup state. A problem exists with the projector that does not prevent it from operating.
	Flashing	Warning with light source on	Light source is on. A problem exists with the projector that will not cause it to shut down.
	Flashing yellow/blue	Warning during cool down	Projector is in a cool down state. Light source is off. Video electronics and light source are cooling down. A problem exists with the projector that does not prevent it from operating.
Red	Solid	Error in standby	Projector is in standby. An error exists that prevents the projector from starting up.
	Flashing	Error	An error with the projector exists during startup, cool down, or when the light source is off. Projector will proceed to shut down.
Off		AC off	The AC power is off.

Projector LED shutter indicators

Identify the shutter LED state colors and meaning.

LED	State	Description
Solid magenta	Shutter closed	The shutter is closed. In standby, the shutter is always automatically closed and the magenta light is muted.
Off	Shutter open	The shutter is open.

Adjusting the image

Adjust the projector image. Christie recommends warming the lens before completing these procedures as focus may change as the lens warms.

Selecting screen image orientation

Specify the orientation to use for the image. The projector supports front projection, rear projection, front projection inverted, or rear projection inverted.

1. Select **MENU > Image Settings > Image Orientation**.
2. Select the required orientation from the list.
3. To confirm your selection, press **Enter**.

Setting the image resize preset

Set the image resize preset to determine if an image will display in its native resolution or will resize by maximizing the height, width, both height and width, or to the maximum size while keeping the original aspect ratio.

1. Select **MENU > Image Settings > Size & Position > Resize Presets**.
2. Select the appropriate resize preset:
 - **Auto**—Maximize for current source.
 - **No Resizing**—Display in native resolution.
 - **Full Size**—Fill the screen, regardless of source.
 - **Full Width**—Fill display width and keep aspect ratio.
 - **Full Height**—Fill display height and keep aspect ratio.
3. Select **Enter**.

Adjusting lens settings

Adjust various lens settings including the offset, zoom, focus, and locking the lens motor.

Adjusting offset

Adjust the offset to align the image on the screen. Always adjust offset before adjusting boresight.



For the best optical performance and minimal keystone, use offsets instead of aiming at the center of the image, in off-axis installations. Avoid extreme tilts or offsets. Corner vignettes on a white test pattern indicate extreme offset that should be avoided using mechanical alignment.

1. Project an image with the primary lens.

2. Select a framing test pattern.
3. Select **LENS OFFSET**.
You can also select **MENU > Configuration > Lens Settings > Lens Offset**.
4. Use the arrows to adjust the offset to display a square image on the screen, with minimal projector aiming error.
5. To exit to the home page, select **Back**.

Resetting the lens to home position

Set the lens offset back to the home position.

1. Select **LENS OFFSET**.
You can also select **MENU > Configuration > Lens Settings > Lens Offset**.
2. To reset the lens to the default home position, select **Reset**.
3. To confirm the reset, select **Reset Lens Position**.

Aligning the image with lens zoom and focus

Ensure that the image reflected from the digital micromirror device (DMD) is parallel and centered with the lens and screen.

1. Display an image or test pattern that can be used to analyze image focus and geometry.
2. Select **Lens Zoom**.
You can also select the zoom function from **MENU > Configuration > Lens Settings > Zoom**.
3. Use the up and down arrows to zoom in or out of the image.
4. To exit, select **Back**.
5. Select **FOCUS**.
You can also select the focus function from **MENU > Configuration > Lens Settings > Focus**.
6. Use the up and down arrows to adjust the focus of the image.
7. To exit on the display panel, select **Back**.
8. To refine your adjusts, repeat steps 2 to 7.

Locking the lens motor

Prevents all lens motors from moving. It disables the zoom, focus, and offset settings, locking out any changes and overriding all other lens features. This feature prevents accidental lens position changes in multi-projector installations.

1. Select **MENU > Configuration > Lens Settings > Lock all Lens Motors**.
2. To enable locking of all lens motors, select **Enter**.

Calibrating the zoom motor

Calibrate the zoom motor to ensure all zoom controls for the lens are enabled.

1. Select **MENU > Configuration > Lens Settings > Zoom Lens Calibration**.

Issuing the (LCB+ZOOM 1) serial command also manually calibrates the lens.

2. To start the calibration, select **Calibrate Zoom Lens**.
3. At the confirmation prompt, select **Calibrate Zoom Lens**.
The Zoom menu item is greyed out until the calibration is complete, which can take up to a minute.

Determining what lens warnings are displayed

Controls the level of lens warnings displayed.

1. Select **MENU > Configuration > Lens Settings > Lens Warnings**.
2. Select the appropriate lens warning level:
 - **Show All Warnings**—Shows all lens warnings.
 - **Hide Zoom Motor Warnings**—Hides zoom motor warnings. Christie recommends selecting this option when using a fixed lens as all zoom operations are disabled.
 - **Hide Detection Warnings**—Hides lens detection warnings. Christie recommends selecting this option when using a third-party lens.
3. Select **Enter**.

Lens control limitations

The projector has keep-out areas for the lens position, illustrated below. When adjusting the lens offset, these regions are unavailable to prevent interference and potentially damage of internal components.

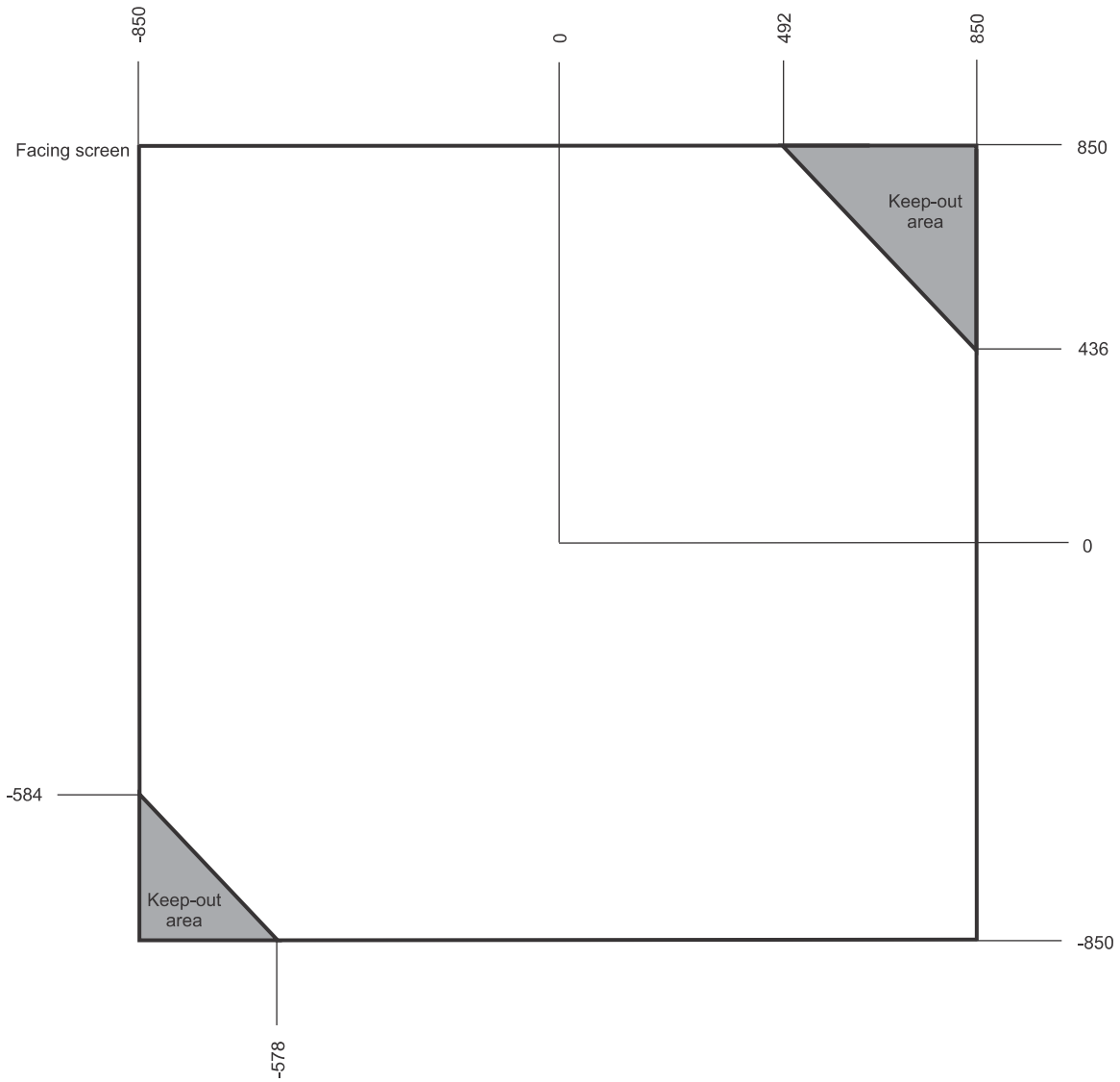

Ultra short throw lens control limitations

The projector has keep-out areas for the ultra short throw lens position, illustrated below. When adjusting the lens offset, these regions are unavailable to prevent interference and potentially damage of internal components.

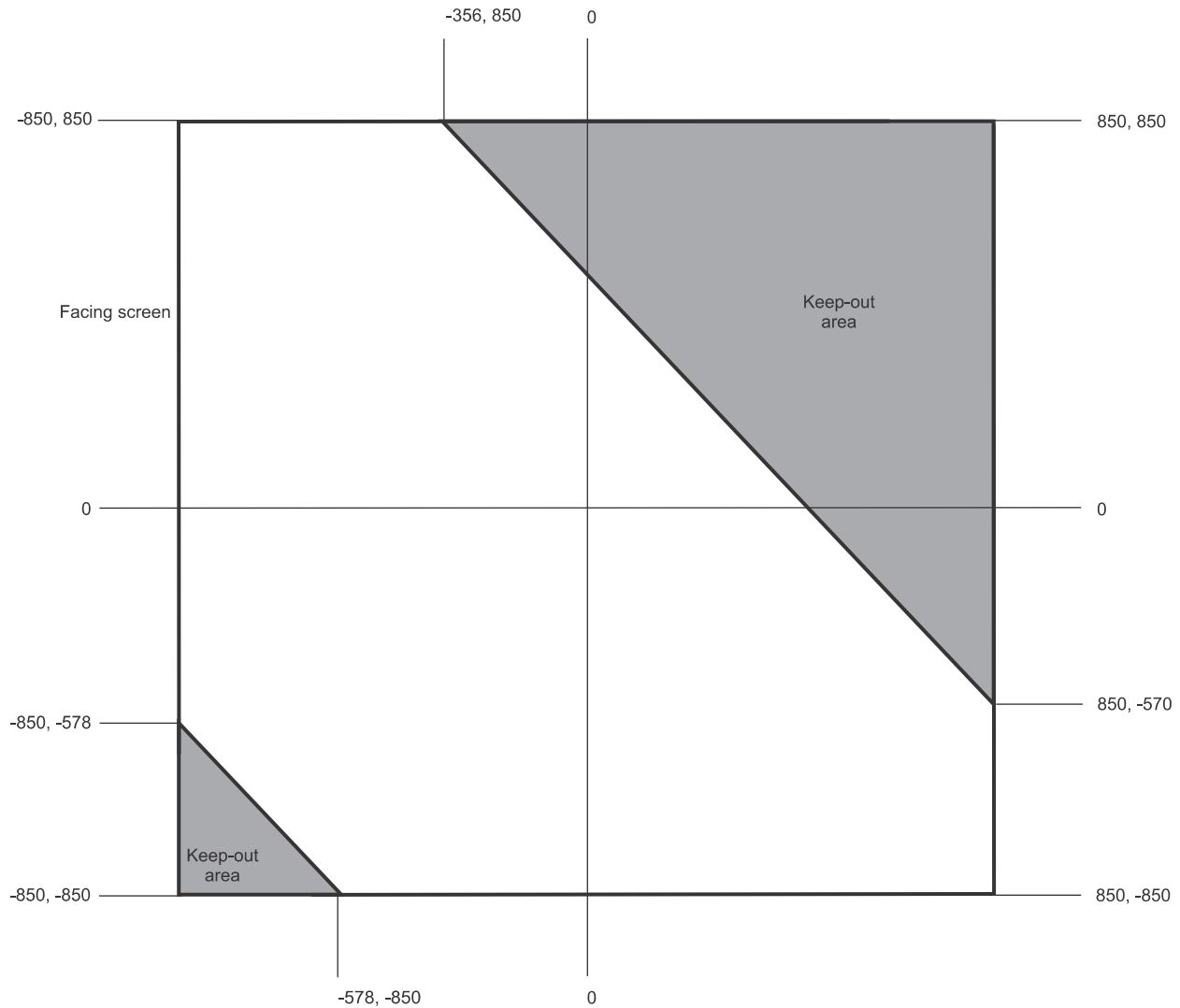

Enabling the ultra short throw lens keep-out area

Not switching to the ultra short throw lens keep-out area risks damaging the projector when an ultra short throw lens is installed.

1. Select **MENU > Configuration > Lens Settings**.
2. Select **Enable UST Lens 0.38:1**.
3. To enable the ultra short throw lens keep-out area, select **Enter**.
The reduced keep-out area is implemented and the lens offset is set to zero.
4. To use a non-ultra short throw lens, clear the checkbox to disable this option.

Adjusting primary colors

Calibrate the accuracy of primary colors, which can change because of lighting and environmental factors.

All primary colors in the projector are precisely set to pre-established values to ensure overall color performance is optimized and is as accurate as possible. Lighting and other environmental factors may slightly change how these colors appear on your screen. While the change is negligible in most cases, you may prefer to recover the originally intended color performance before trying to match colors from several projectors.

To achieve consistency use a color meter to measure the native primary colors—red, green, blue, and white—as they appear on the screen. On the basis of these new values, which are stored in memory, each projector automatically calculates any necessary corrections to reproduce the original factory colors under the current environmental conditions. This essentially calibrates a projector to its surroundings, compensating for factors such as screen type, light source and/or ambient lighting, and improves color accuracy and consistency in a group of projectors. It ensures a good starting point for further customizing and matching; however, is not critical for all installations.

1. From the display panel, select **MENU > Configuration**.
2. Select **Color Primary Settings**.
3. To edit the primary colors settings, select **Edit**.
4. Adjust the slider or enter the measured color values of the primary color component you selected.
5. To confirm your selection, select **Enter**.
6. Repeat steps 4 and 5 for each primary color component.
7. To view a specific color while adjusting, select **Show Color Pattern**.
8. Select the appropriate color and select **Enter**.
9. To reset the primary colors to their defaults, select **Reset Color Primaries**.
10. At the confirmation prompt, select **Reset**.

DMD color correction

Adjust the DMD color values as required.

Adjusting color by precise chromaticity values

Change the values of the primary color components.

1. Select **MENU > Configuration > Color Correction by x,y**.
2. To edit the custom color correction settings, select **Edit**.
3. Adjust the slider or enter the measured color values of the primary color component you selected.
4. To confirm your selection, select **Enter**.
5. Repeat steps 3 and 4 for each primary color component.
6. To view a specific color while adjusting, select **Show Color Pattern**.
7. Select the appropriate color and select **Enter**.

Adjusting color by saturation

Change the strength of the primary color in relation to the other primary colors.

1. Select **MENU > Configuration > Color Saturation**.
2. To edit the custom color correction settings, select **Edit**.
3. Adjust the value of the primary color you selected by using more or less of it in relation to the other primary colors.
4. To confirm your selection, select **Enter**.
5. Repeat steps 3 and 4 for each primary color.
6. To view a specific color while adjusting, select **Show Color Pattern**.
7. Select the appropriate color and select **Enter**.

Signal color correction

Adjust the video signal color as required.



For best results, Christie recommends setting all color and gamma settings to **Auto Detect**.

Adjusting the color space

Determine how the color components are decoded for accurate color in the display.

1. Select **MENU > Image Settings > Color & Gamma > Color Space**.
2. Select the adjustment most suited to the input signal:
 - Auto Detect
 - RGB (Full Range)
 - RGB (Limited Range)
 - YCbCr HDTV (Expanded Range)
 - YCbCr JPEG (Full Range)
 - YCbCr UHD TV (ITU-R BT.2020) (Full Range)
3. Select **Enter**.

Adjusting color by temperature

Adjust the color temperature as expressed in degrees Kelvin.

1. **MENU > Image Settings > Color & Gamma > Color Correction Mode**.
2. From the list, select **Color Temperature**.
3. Select the **Color Temperature** option.
4. Adjust the slider to change the light to warmer or cooler and select **Enter**.

Selecting the color correction mode

Select the color correction mode most suited to the input signal.

1. Select **MENU > Image Settings > Color & Gamma > Color Correction Mode**.
2. Select the adjustment most suited to the input signal:
 - **Auto Detect**—Automatically detect the appropriate color correction mode, where possible.
 - **Max Drives**—All color adjustments are turned off, allowing the projector to run at maximum brightness.
 - **Color Temperature**—Specify a color temperature between 3200 and 9300, expressed in degrees Kelvin.
 - **HD Video**—Set the output color to a specific standard value. Adjusts the colors red, green, blue, and white.
 - **DCI P3**—Set the DCI P3 (cinema) colorimetry with DCI white point.
 - **DCI P3 (D65)**—Set the DCI P3 colorimetry with D65 white point.
 - **Custom**—Select a user defined set of color adjustments.
3. Select **Enter**.

Correcting for ambient light

Ambient light is the natural light that occurs in the environment where the projector is located.

1. Select **MENU > Image Settings > Color & Gamma > Ambient Light Correction**.
2. Select **Enter**.
3. Use the right and left arrows to adjust how the image displays in conditions with ambient light.
4. To confirm your selection, select **Enter**.

Setting the frame delay

Delay the output signal timing relative to the input signal timing by a fraction of a frame, and up to several frames.

The minimum latency can vary based on the amount of scaling applied to the image. When using keystone or warping, an additional latency is required, depending on the amount of warp.

1. Select **MENU > Image Settings > Advanced Image Settings > Frame Delay**.
2. To set the total video frame delay, select **Set Delay**.
3. Adjust the value and to confirm your selection, select **Enter**.

The Actual Delay field reports what the system has delivered for the frame delay. The value is reported in frames and milliseconds.

Enabling film mode detect

Enables or disables the detection of film motion.

1. Select **MENU > Image Settings > Advanced Image Settings > Film Mode Detect**.

2. To enable the detection of film motion, select **Auto Detect**.
3. To disable the detection of film motion, select **Disabled**.
4. Select **Enter**.

Adjusting the image sharpness

Change the sharpness of the image.

Lower settings can improve a noisy signal. Setting the sharpness above the halfway point can introduce noise in the image.

1. Select **MENU > Image Settings > Advanced Image Settings > Sharpness**.
2. Select **Enter**.
3. Use the right and left arrows to adjust the sharpness of the image.
4. To confirm your selection, select **Enter**.

Creating a seamless image with edge blending

Combine several projected images into one single, seamless image with edge blending.

Adding edge blends to the projector

Use or to create edge blends and upload them to Mirage SST.

1. Create an edge blend file using the or application.
To connect Mirage SST with or , use port 3003.
Christie Twist Premium, Twist Pro, and offer advanced warping options. Refer to the Christie website (www.christiedigital.com) for product information and documentation.
2. Upload the edge blend file to the projector.
3. On one projector, select **MENU > Configuration > Edge Blending**.
4. Select the appropriate edge blend setting and select **Enter**.
5. Repeat steps 2 to 4 for the remaining projectors.
6. To turn off edge blending, from **MENU > Configuration > Edge Blending**, select **Off**.

Enabling basic edge blending

Create basic edge blends directly on Mirage SST.

1. Start with two projectors and display the full white field test pattern from both.
2. On one projector, select **MENU > Configuration > Edge Blending**.
3. To enable basic edge blending, select **Basic**.
4. To edit blending adjustments, select **Edge Blend Widths**.
5. From the Basic Blending dialog, select a side to blend.
6. To make the blending adjustments, use the arrow keys to change either the vertical and horizontal values as appropriate.

7. To accept the selection, select **Enter**.
8. Repeat steps 4 to 6 to blend the remaining sides.
9. When all adjustments are made, use the arrow keys to highlight **Apply** and select **Enter**.
10. Repeat steps 2 to 9 for the remaining projectors.
11. To turn off basic edge blending, from **MENU > Configuration > Edge Blending**, select **Off**.

Resetting edge blending

Reset the edge blending to revert any edge blends.

1. Select **MENU > Configuration > Edge Blending**.
2. Select **Reset Edge Blends**.
3. At the confirmation prompt, select **Reset**.

Geometry correction

Modify the geometry for all sources.

Enabling warping

Use warping to project images on any surface shape.

1. Create a warp file using the or application.
To connect Mirage SST with or , use port 3003.
Christie Twist Premium, Twist Pro, and offer advanced warping options. Refer to the Christie website (www.christiedigital.com) for product information and documentation.
2. Upload the warp file to the projector.
3. Select **MENU > Configuration > Geometry Correction > Geometry Correction Mode**.
4. Select the appropriate warp setting and select **Enter**.
5. To turn off warping, from **MENU > Configuration > Geometry Correction > Geometry Correction Mode**, select **Off**.

Pressing **Func+Help** on the IR remote keypad disables all geometry corrections (warping, keystone, and black level blending) without changing the settings associated with them.

Correcting the shape of a keystone image

Keystone effect occurs when you project an image onto the screen at an angle and the projector is not centered on the screen. The image appears distorted and resembles a trapezoid.

To correct the shape of a keystone image, use the keystone options available in the geometry correction menu. Perform coarse keystone adjustments by using the horizontal or vertical settings. It may not be possible to match the screen dimensions with the horizontal and vertical keystone controls but you can refine these settings by adjusting the 2D keystone settings.

Enabling keystone adjustments

Enable keystone corrections to correct the shape of a keystone image.

1. Select **MENU > Configuration > Geometry Correction > Geometry Correction Mode**.

2. Select **Keystone**.
Any keystone adjustments previously set are enabled.
To disable keystone adjustments, select **MENU > Configuration > Geometry Correction > Geometry Correction Mode > Off**.

Adjusting the image with 2D keystone

2D keystone distorts the projected image both vertically and horizontally simultaneously and resembles a trapezoid.

Adjusting horizontal or vertical keystone correction after 2D keystone erases the 2D keystone settings; however, performing 2D keystone after horizontal or vertical correction retains the previous keystone setting.



1. Select **MENU > Configuration > Geometry Correction > Geometry correction Mode**.
2. Select **2D Keystone Correction**.
3. From the correction dialog, select the corner to adjust.
4. To make the keystone adjustments, use the arrow keys to change both the vertical and horizontal values.
5. Select **Apply Changes**.

Adjusting vertical keystone

Use vertical keystone to correct a keystone image shape in which the top and bottom borders of the image are unequal in length, and both sides of the image are inclined toward the top or bottom edge.

If vertical keystone adjustments have been made, starting horizontal keystone adjustments erases the vertical settings.



1. Select **MENU > Configuration > Geometry Correction > Geometry Correction Mode**.
2. Select **Vertical Keystone Correction**.
3. From the correction dialog, adjust the vertical keystone by using the arrow keys.
4. Select **Apply Changes**.

Adjusting horizontal keystone

Use horizontal keystone to correct a keystone image shape in which the left and right borders of the image are unequal in length, and the top and bottom are slanted to one of the sides.

If horizontal keystone adjustments have been made, starting vertical keystone adjustments erases the horizontal settings.

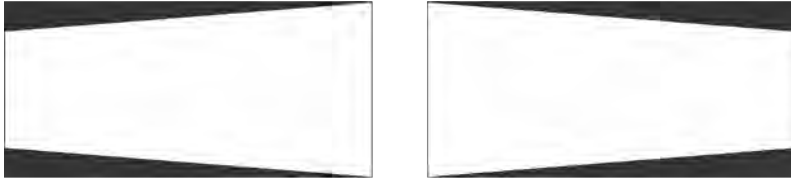

1. Select **MENU > Configuration > Geometry Correction > Geometry Correction Mode.**
2. Select **Horizontal Keystone Correction.**
3. From the correction dialog, adjust the horizontal keystone by using the arrow keys.
4. Select **Apply Changes.**

Resetting keystone correction

Reset keystone to revert the distorted image shape back to default values.

Pressing **Func+Help** on the IR remote keypad disables all geometry corrections (warping, keystone, and black level blending) without changing the settings associated with them.

1. Select **MENU > Configuration > Geometry Correction.**
2. Select **Reset Keystone Correction.**
3. At the confirmation prompt, select **Reset.**

Configuring system settings

Learn how to configure the system settings.

Setting the date

Configure the date on Mirage SST.

1. Select **Menu** > **System Settings** > **Date & Time**.
2. Select **Date**.
3. Use the up and down keys to adjust the year (YYYY), month (MM), and day (DD).

Setting the time

Configure the time on Mirage SST.

1. Select **Menu** > **System Settings** > **Date & Time**.
2. Select **Time**.
3. Use the up and down keys to adjust the hour (HH), minutes (MM), and seconds (SS).

Changing the splash screen

Select the color displayed on the screen.

1. Select **MENU** > **System Settings** > **Splash Screen Settings** > **Background Color**.
2. Select a splash screen background color:
 - Black
 - Red
 - Green
 - Blue
3. Select **Enter**.

Determining the on-screen display position

Choose one of the pre-defined locations for the display of the on-screen menus.

1. Select **MENU** > **System Settings** > **Menu Preferences** > **OSD Position**.

2. Select the location on the screen where you want the on-screen display menus to appear.
3. Select **Enter**.

Changing the language

Choose the language you want displayed on projector display panel and on-screen display.

1. Select **MENU > Languages**.
You can also select the language from **MENU > System Settings > Menu Preferences > Languages**.
2. Select **Enter**.
3. Select the appropriate language and select **Enter**.
The change takes effect immediately.

Changing the temperature units

Set if the temperature is measured in Celsius or Fahrenheit.

1. Select **MENU > System Settings > Menu Preferences > Temperature Units**.
2. Select the temperature unit: **Celsius** or **Fahrenheit**.
3. Select **Enter**.

Changing the user account password

The user account password limits access to the functionality on the web interface to authorized users.

Christie recommends changing the default user account password.



This feature is only available on the web interface.

1. From the home page of the web interface, select **MENU > Admin > Remote Password**.
2. Click the **Current Password** and type your current password.
3. Click **New Password** and type your new password.
Create your password using 4 to 32 characters. The password can be any combination of letters, numbers, and symbols (ASCII-standard characters only). Accents and accented characters are not supported.
4. Click **Confirm** and retype your new password.
5. Click **Apply**.

Accessing the generated user account password

If the user account password is not available, the generated password can be used to access the functionality on the web interface.

Note the following about the generated user account password:

- The generated password can be used to change the user account password.

- Every time the user account password is updated, the generated password is changed.



This feature is accessed from the display panel on the projector and the on-screen display.

Select **Generated password**.

The generated password is displayed in this field.

Turning on the projector with low voltage

Enable the projector to turn on even if the AC mains voltage is below specification.

1. From the display panel, select **MENU > Admin > Service**.
2. Enter the service password.
The password is only required for the display panel and not the web user interface.
3. Select **Ignore Low AC Input Voltage Error**.
4. To ignore the Low AC Input Voltage error when turning on the projector, select **Enter**.

Resuming projector operation after an AC power interruption

If an AC power interruption occurs while Auto Power Up is enabled, the projector will resume operation in the same state it was prior to the loss of power.

1. Select **MENU > System Settings > Power Settings**.
2. Select **Auto Power Up**.
3. To enable automatically powering up the projector after an AC interruption, select **Enter**.

Keeping electronics on in standby mode

When the projector is placed in standby mode, the light source will be turned off but the electronics and required fans remain on.

1. Select **MENU > System Settings > Power Settings**.
2. Select **Keep Electronics On In Standby**.
3. To enable electronics remaining on in standby mode, select **Enter**.

Enabling direct pass-through of HDMI, 3G, and DisplayPort input signals

Allow the signals from HDMI, 3G, and DisplayPort inputs to pass through another projector.

1. Select **MENU > Configuration > Input Settings > Enable Video Loop Out**.

2. To enable passing HDMI, 3G, and DisplayPort input signals through to another projector, select **Enter**.

Configuring video input

Defines which video inputs are available. This setting is persistent so when the projector powers up, it loads the video input defined below.



When changing the selection, the system takes up to 15 seconds to re-configure. During this time the user interface is not responsive.

1. Select **MENU > Configuration > Input Settings > Video Input Configuration**.
2. Select the appropriate video input configuration:
 - **Default**—Supports HDMI, DP, SDI, HDBaseT, and ChristieLink. (Default)
 - **SDVoE**—Supports HDMI, SDVOE, HDBaseT, and ChristieLink.
3. Select **Enter**.

Disabling secondary DVI receivers

In some cases when using single-link DVI signals, the unused secondary receivers disrupt the signal detection logic. Disable the secondary receivers if occasional screen flashes are seen while the projector attempts to re-synchronize to the incoming video.

1. Select **MENU > Configuration > Input Settings > Disable Secondary DVI Receiver on DDIC**.
Issuing the (DDD 1) serial command also disables the secondary receivers.
2. To disable the secondary receivers, select **Enter**.

Informing the source of signal preferences

Configure Mirage SST to automatically inform the video source of the preferred signal formats.

1. If you need a specific frame rate, from the display panel, select **MENU > Configuration > Input Settings > EDID Timing**.
2. Select the required EDID timing and select **Enter**.
60 Hz is the default EDID timing.

Christie high frame rate

High frame rate (HFR) content plays at higher speeds so viewers see fewer motion artifacts, as well as less motion blur and stuttered movement on-screen.

Increasing the frame rate not only provides more frames to better represent fast moving objects, it also provides increased image detail as there is less dark time in between frames.

Required components

The following components are required.

- Mirage Pro license

Additional components

- Christie Twist 2.5

Video sources

Three video sources and Christie Link are supported for Christie high frame rate.



- All sources must be frame synchronous.
- 1920 x 1080 (FHD) image formats are supported.
- 1/1.001 fractional frame rates are supported.

System	Layout	Port	Signal
QDPIC	1-port	[0-1] [0-2] [0-3] [0-4]	2048 * 1080 @ 240Hz
	2-port	[0-1][0-2] [0-3][0-4]	1024 * 1080 @ 240Hz 1024 * 1080 @ 360Hz 1024 * 1080 @ 480Hz
	4-port	[0-1][0-2][0-3][0-4]	1024 * 540 @ 480Hz
HBMIC	1-port	[0-4]	2048 * 1080 @ 240Hz
	(QSFP+)	See the Christie Link section below	
TDPIC	2-port	[1-1][2-1] [3-1][4-1] [1-2][2-2] [3-2][4-2]	1024 * 1080 @ 240Hz
	4-port	[1-1][2-1][3-1][4-1] [1-2][2-2][3-2][4-2]	1024 * 540 @ 240Hz 1024 * 540 @ 360Hz 1024 * 540 @ 480Hz
Christie Link	1-port	[0-1] [0-2]	2048 * 1080 @ 240Hz
	2-port	[0-1][0-2]	1024 * 1080 @ 240Hz 1024 * 1080 @ 360Hz 1024 * 1080 @ 480Hz

Enabling or disabling the high frame rate (HFR)

If the high frame rate (HFR) mode is enabled, the projector can only operate in 2K/HD output resolution. To use 4K/UHD resolution, disable this mode.



This option is only available when the Mirage Pro license is installed and the projector is in standby mode.

1. Select **Menu > Configuration > Input Settings > High Frame Rate**.
2. To change to 2K/HD resolution for HFR, select **Enable**.
3. At the confirmation prompt, select **Enable**.
The projector reboots and the High Frame Rate button changes to Disable.
4. To change to 4K/UHD resolution, select **Menu > Configuration > Input Settings > High Frame Rate > Disable**.
The projector reboots and the High Frame Rate button changes to Enable.

Issuing the (OTR <0 | 1>) serial command for the Griffyn Series and Mirage SST also toggles between the 4K and 2K resolutions.

Selecting the high frame rate EDID

Configure the projector and/or Christie Link for the 3D source.

1. From the projector:
 - a) Select **MENU > Configuration > Input Settings > EDID Timing**.
 - b) Select one of the following EDID timings: 240Hz, 360Hz, or 480Hz.
 - c) Select **Enter**.
2. From Christie Link:
 - a) Select **MENU > Configuration > INPUT PORTS > EDID Timing**.
 - b) Select one of the following EDID timings: 240Hz, 360Hz, or 480Hz.
 - c) Select **Enter**.

Configuring the laser power settings

Projector profiles contain the power settings for the RGB laser light source.

1. To display the white test pattern, **MENU > Test Pattern**
2. Scroll through the list of test patterns and select **White**.
3. To confirm your selection, select **Enter**.
4. To indicate the maximum expected room temperature, select **MENU > Configuration > Light & Output Settings > Max Ambient Temperature**.
5. For 80K right-eye (Type B: RGB-80-3P-2 fiber laser) and 100K (Type A: RGB-100-3P fiber laser) rack types, the maximum expected room temperature is required to provide constant brightness up to that temperature level. If applicable, indicate the maximum expected room temperature by selecting **MENU > Configuration > Light & Output Settings > Max Ambient Temperature**.

- a) Use the **Max Ambient Temperature** slider to increase and decrease the maximum ambient temperature you expect the room to reach and select **Enter**.
The system uses the maximum expected room temperature to calculate the light output (**Maser Laser Power**). The default maximum expected room temperature setting is 25° C. A lower room temperature generally results in increased brightness and better efficiency. A higher room temperature reduces the maximum power setting available for the lasers. The maximum expected room temperature setting must reflect the anticipated operating conditions.
6. Select **MENU > Image Settings > Color & Gamma > Color Correction Mode**.
7. Select **Max Drives** and to confirm your selection, select **Enter**.
8. Select **MENU > Configuration > Light & Output Settings**.
9. To set the approximate red power level, select **Red Laser Setpoint** and use the slider to increase and decrease the value required for your projection environment.
To turn off the red lasers but leave them in a ready state, select **Red Laser Enable** to clear the checkbox.
10. To set the green (**Green Laser Setpoint**) and blue (**Blue Laser Setpoint**) power levels, repeat step 9.
To turn off either the green or blue lasers but leave them in a ready state, select **Green Laser Enable** or **Blue Laser Enable** to clear the checkbox.
11. If color is not at the target level, refine the red, green, and blue power settings to achieve the target by repeating steps 9 and 10.
12. To control the brightness once the colors are set, select **Maser Laser Power** and use the slider to increase or decrease the value.
To turn off all lasers but leave them in a ready state, select **Maser Laser Enable** to clear the checkbox.
13. To save the new laser settings, save to a projector profile.

Setting up 1D color uniformity

Learn how to set up 1D color uniformity on the projector after taking measurement of each of the color primaries at points (15, 2, 5, 8, and 16).

1. Ensure the projector is running in representative ambient light.
2. Setup a spectroradiometer, such as the CR-250, on a tripod.
If not using the CR-250 or better, Christie recommends placing the meter perpendicular to the screen to achieve accurate measurements.
Do not use the PR-655 spectroradiometer to perform color uniformity on a multi-projector installation.
3. Power on the projector.
4. Allow the light source to stabilize.
5. From the side panel home page, use the arrows to select **Test Pattern**.
6. Select the **17 Point test pattern** and to confirm your selection, select **Enter**.



7. Select **MENU > Configuration > Horizontal 1D Color Uniformity > Color Uniformity Mode**.
8. To disable color uniformity, select **Color Uniformity Off**.
9. Select **Enter**.
10. Select **Color Correction Mode > Max Drives** and to confirm your selection, select **Enter**.
11. Select **Show Color Pattern > Auto** and to confirm your selection, select **Enter**.
12. Record the x, y, and RGB luminance values for the center point.
 - a) Point the spectroradiometer at point 5 (middle square).
 - b) Click the X value.
 - c) Record the x value from the spectroradiometer in the projector user interface.
 - d) Click the Y value.
 - e) Record the y value from the spectroradiometer.
 - f) Click on the Red luminance setting.
The display changes to the appropriate color.
 - g) Record the luminance value from the spectroradiometer.
 - h) Click on the Green luminance setting.
The display changes to the appropriate color.
 - i) Record the luminance value from the spectroradiometer.
 - j) Click on the Blue luminance setting.
The display changes to the appropriate color.
 - k) Record the luminance value from the spectroradiometer.
13. Record the luminance values for the remaining four points (2—inside left, middle square; 15—far left, middle square; 8—inside right, middle square; and 16—far right, middle square)
 - a) Point the spectroradiometer at a point.
 - b) Click on the Red luminance setting.
The display changes to the appropriate color.
 - c) Record the luminance value from the spectroradiometer in the projector user interface.
 - d) Click on the Green luminance setting.
The display changes to the appropriate color.
 - e) Record the luminance value from the spectroradiometer.
 - f) Click on the Blue luminance setting.
The display changes to the appropriate color.
 - g) Record the luminance value from the spectroradiometer.

- h) For the remaining three points, repeat steps a to g.
14. To enable color uniformity, select **Color Uniformity Mode > Horizontal 1D Color Uniformity** and to confirm your selection, select **Enter**.
 15. To verify 1D color uniformity is working, enable a flat white test pattern.

Determining shutter operation during projector on sequence

Enables or disables the opening the shutter during the projector power on sequence.

When this setting is changed, it is applied during the time the laser is powered on and is persistent over AC cycles.

1. Select **MENU > Configuration > Light & Output Settings > Shutter Inhibit**.
2. To disable the shutter opening automatically during power on, select **Enter**.
The checkbox is selected and the shutter remains closed when the laser is powered on and must be opened manually.
3. To enable the shutter opening automatically during power on, select **Shutter Inhibit** again to clear the checkbox.

Configuring communications

Defines and controls how single or multiple projectors are linked with each other and with a controlling device.

Enabling projector communication

Enable the receivers and the wired keypad to communicate with the projector from the remote.

The front and rear IR sensors receive transmissions from the IR remote. Keep the transmission path to these sensors unobstructed for uninterrupted communications with the projector.

Alternatively, you can connect a wired version of the remote to the connector on the IMXB labeled Wired Keypad.

1. Select **MENU > Communications > Projector Communications**.
2. To assign the projector an ID, select **Projector ID**.
3. Use the up and down keys to enter the projector ID.
4. Select **Enter**.
5. To enable the rear IR sensor, select **Rear IR Enabled** and select **Enter**.
6. To enable a wired version of the remote, select **Wired Keypad Enabled** and select **Enter**.
By default this feature is enabled.

Setting the remote access level

Determine if and how the projector can be accessed remotely for the RS232 port or the Ethernet.

1. From the display panel, select **MENU > Admin > Service**.
2. Enter the service password.
The password is only required for the display panel and not the web user interface.
3. To determine the remote access for the Ethernet port, select **Remote Access Level (Ethernet)**.
4. Select the appropriate remote access level:
 - No Access
 - Login Required
 - Free Access
5. Select **Enter**.
6. To determine the remote access for the RS232 IN port, select **Remote Access Level (RS232 IN)**.

7. Select the appropriate remote access level:
 - No Access
 - Login Required
 - Free Access
8. Select **Enter**.

Communicating with Mirage SST through Art-Net

Mirage SST supports communications through the Art-NET using the Ethernet connector.

1. Select **MENU > Communications > Art-Net Settings**.
2. Verify the **Enable Art-Net** option is disabled.
Disabling Art-Net before configuring it ensures Mirage SST does not accidentally respond to DMX messages destined for other devices on the network.
3. To specify which subnet the projector belongs to, in the Art-Net Subnet field adjust the value between 0 and 15.
The subnet provides expandability beyond the universe level.
4. To confirm your selection, select **Enter**.
5. To specify which universe the projector belongs to, so it can filter out all other data packets, in the Art-Net Universe field, adjust the value between 0 and 15.
For Art-Net, data is broadcast over an Ethernet network, so every device receives every packet of data, whether the device belongs to that universe or not.
6. To confirm your selection, select **Enter**.
7. To determine the starting channel for this projector, in the Base Channel field, adjust the value between 1 and 488.
If multiple projectors are used on the same universe and are to be controlled independently, this value must be changed. For example, if both projectors are using the Shutter (20 channels), projector 1 should start at base channel 1 and projector 2 should start at base channel 21.
8. To confirm your selection, select **Enter**.
9. Select **Enable Art-Net**.
10. To enable the Art-Net functionality, select **Enter**.

Art-Net channel listing

There are 512 channels per universe. Mirage SST specifies 24 channels.



Mirage SST has multiple methods of being controlled in addition to Art-Net. If a setting is changed through another interface, the DMX controller can re-assert control by changing the value on the appropriate DMX channel.

Channel	Name	Description	Suggested starting position	Notes
1	Slider Lock	0 to 171 = Locked 172 to 255 = Unlocked	0	—

Channel	Name	Description	Suggested starting position	Notes
2	Power	0 to 85 = Powers off the projector (goes into Standby mode) 86 to 171 = Cancel timer 172 to 255 = Powers on the projector (switches light source on, warm up mode)	128	Must be valid for five seconds before it is applied.
3	Shutter	0 to 85 = Closes the shutter (black screen) 172 to 255 = Opens the shutter (live video)	255	Christie recommends setting this channel to 255 prior to powering up the projector so it is consistent with the shutter state after the projector is fully on.
4	Lens Shift Enable	0 to 171 = Disables lens shift 172 to 255 = Enables lens shift	—	Locks all lens motors.
5	Zoom (Coarse)	0 = Smallest image possible (0%)	128	<ul style="list-style-type: none"> • Locked by the Lens Shift Enable channel. • Scaled as a percentage of the total control range. • A 250 ms delay exists before sending this channel to the projector.
6	Zoom (Fine)	255 = Largest image possible (100%)		
7	Focus (Coarse)	0 = 0%	128	<ul style="list-style-type: none"> • Locked by the Lens Shift Enable channel. • Scaled as a percentage of the total control range. • A 250 ms delay exists before sending this channel to the projector.
8	Focus (Fine)	255 = 100%		
9	Lens Horizontal Position (Coarse)	0 = Full left position (0%)	128	<ul style="list-style-type: none"> • Locked by the Lens Shift Enable channel. • A 250 ms delay exists before sending this channel to the projector.
10	Lens Horizontal Position (Fine)	255 = Full right position (100%)		
11	Lens Vertical Position (Coarse)	0 = Full lower position (0%)	128	<ul style="list-style-type: none"> • Locked by the Lens Shift Enable channel. • A 250 ms delay exists before sending this channel to the projector.
12	Lens Vertical Position (Fine)	255 = Full upper position (100%)		

Channel	Name	Description	Suggested starting position	Notes
13	Input	1 to 80 = Input index 86 = Load 91 to 170 = Additional input indices 171 = Execute	0	To change inputs, send the following sequence: Load > Input index > Execute Channel 1 slider lock can be used if a keypad is not available for the input selection.
14	Fade Time	0 = 0 seconds 250 = 2.5 seconds	—	Determines the length of time it takes for the shutter to open and close with a fading effect.
15 to 24	Reserved	Reserved for future use.	—	—

Index list for the input channel

the following table provides the index information for the input channel.



Not all options listed in the table are available on all products. Available options depend on the projector model and the cards installed on the projector. The QSFP+ options require the **Enable Christie Link** option to be set.

Input index	Description	Input index	Description
1	One-port [0-1]	44	Four-Port [1-2][2-2][3-2][4-2]
2	One-port [0-2]	45	One-Port, Dual-Input 3D L:[0-1],R:[0-2]
3	One-port [0-3]	46	One-Port, Dual-Input 3D L:[0-3],R:[0-4]
4	One-port [0-4]	47	One-Port, Dual-Input 3D L:[1-1],R:[1-2]
5	One-Port [1-1]	48	One-Port, Dual-Input 3D L:[1-3],R:[1-4]
6	One-Port [1-2]	49	One-Port, Dual-Input 3D L:[2-1],R:[2-2]
7	One-Port [1-3]	50	One-Port, Dual-Input 3D L:[2-3],R:[2-4]
8	One-Port [1-4]	51	One-Port, Dual-Input 3D L:[3-1],R:[3-2]
9	One-Port [2-1]	52	One-Port, Dual-Input 3D L:[3-3],R:[3-4]
10	One-Port [2-2]	53	One-Port, Dual-Input 3D L:[4-1],R:[4-2]
11	One-Port [2-3]	54	One-Port, Dual-Input 3D L:[4-3],R:[4-4]
12	One-Port [2-4]	55	One-Port, Dual-Input 3D L:[1-1],R:[2-1]
13	One-Port [3-1]	56	One-Port, Dual-Input 3D L:[1-2],R:[2-2]
14	One-Port [3-2]	57	One-Port, Dual-Input 3D L:[1-3],R:[2-3]
15	One-Port [3-3]	58	One-Port, Dual-Input 3D L:[1-4],R:[2-4]
16	One-Port [3-4]	59	One-Port, Dual-Input 3D L:[3-1],R:[4-1]
17	One-Port [4-1]	60	Two-Port, Dual-Input 3D L:[0-1][0-2],R:[0-3][0-4]

Input index	Description	Input index	Description
18	One-Port [4-2]	61	Two-Port, Dual-Input 3D L:[1-1][1-2],R:[1-3][1-4]
19	One-Port [4-3]	62	Two-Port, Dual-Input 3D L:[2-1][2-2],R:[2-3][2-4]
20	One-Port [4-4]	63	Two-Port, Dual-Input 3D L:[3-1][3-2],R:[3-3][3-4]
22	Two-Port [0-1][0-2]	65	Two-Port, Dual-Input 3D L:[1-1][1-2],R:[2-1][2-2]
23	Two-Port [0-3][0-4]	66	Two-Port, Dual-Input 3D L:[3-1][3-2],R:[4-1][4-2]
24	Two-Port [1-1][1-2]	67	Two-Port, Dual-Input 3D L:[1-1][2-1],R:[3-1][4-1]
25	Two-Port [1-3][1-4]	68	Four-Port, Dual-Input 3D L:[1-1][1-2][2-1][2-2],R:[3-1][3-2][4-1][4-2]
26	Two-Port [2-1][2-2]	69	Four-Port, Dual-Input 3D L:[1-1][1-2][1-3][1-4],R:[2-1][2-2][2-3][2-4]
27	Two-Port [2-3][2-4]	70	Four-Port (columns) [0-1][0-2][0-3][0-4]
28	Two-Port [3-1][3-2]	71	Four-Port (columns) [1-1][1-2][1-3][1-4]
29	Two-Port [3-3][3-4]	72	Four-Port (columns) [2-1][2-2][2-3][2-4]
30	Two-Port [4-1][4-2]	73	Four-Port (columns) [3-1][3-2][3-3][3-4]
31	Two-Port [4-3][4-4]	74	Four-Port (columns) [4-1][4-2][4-3][4-4]
32	Two-Port [1-1][2-1]	75	Four-Port (columns) [1-1][1-2][2-1][2-2]
33	Two-Port [3-1][4-1]	76	Four-Port (columns) [3-1][3-2][4-1][4-2]
34	Two-Port [1-2][2-2]	77	Four-Port (columns) [1-1][2-1][3-1][4-1]
35	Two-Port [3-2][4-2]	78	Four-Port (columns) [1-2][2-2][3-2][4-2]
36	Four-Port [0-1][0-2][0-3][0-4]	79	Four-Port (columns), Dual-Input 3D L:[1-1][1-2][2-1][2-2],R:[3-1][3-2][4-1][4-2]
37	Four-Port [1-1][1-2][1-3][1-4]	80	Four-Port (columns), Dual-Input 3D L:[1-1][1-2][1-3][1-4],R:[2-1][2-2][2-3][2-4]
38	Four-Port [2-1][2-2][2-3][2-4]	91	QSFP+ [0-1]
39	Four-Port [3-1][3-2][3-3][3-4]	92	QSFP+ [0-2]
40	Four-Port [4-1][4-2][4-3][4-4]	93	QSFP+ [1-1]
41	Four-Port [1-1][1-2][2-1][2-2]	94	QSFP+ [1-2]
42	Four-Port [3-1][3-2][4-1][4-2]	95	QSFP+ [2-1]
43	Four-Port [1-1][2-1][3-1][4-1]	96	QSFP+ [2-2]

Working with macros

Automate tasks in Mirage SST with macros so the same tasks can be done on a regular basis.



If the date and/or time is changed on the projector, a macro may be unexpectedly executed.

Adding a Scheduled Event macro

Create a Scheduled Event macro to automate a repetitive task.

Up to 24 macros can be created.



This feature is only available on the web interface.

1. From the home page of the web interface, select **Macros and GPIO**.
2. Click the **Add Macro**.
If the limit of 24 macros is reached, the **Add Macro** button is disabled and displays a Limit Reached message.
3. In the Name field, enter a meaningful name for the macro.
4. From the Type list, select **Scheduled Event**.
5. In the Start Date field, select a date from the calendar.
6. In the Start Time field, use the up and down keys to adjust the hour (HH), minutes (MM), and seconds (SS).
You can also manually enter the hour, minutes, and seconds.
7. To make this a reoccurring event, click **Recurring**.
When enabled, the button appears green. When disabled, the button appears gray.
 - a) To determine the recurrence pattern, under Every, select the day or days of the week you want run the macro.
 - b) Determine the life of the macro.
 - To have the macro run indefinitely, select **No end date**.
 - To run the macro for a defined period of time, in the Recur for field, use the up and down keys to adjust the number of weeks.
You can also manually enter the number of weeks. The limit is 99 weeks.
8. In the Serial Command field, enter the serial command(s) you want to run.
For available serial commands and their syntax, refer to the *Mirage SST Serial Commands Guide (P/N: 020-103005-XX)*.
9. To test the functionality, click **Test**.
An `Action succeeded` message is displayed upon a successful test.
10. To save the macro, click **Save**.

If the time specified in a macro has expired, a warning icon depicting an expired macro is displayed in the title bar.

Copying a macro

Duplicate a Scheduled Event macro to create another macro of similar functionality.

Up to 24 macros can be created. GPIO Event macros cannot be duplicated.



This feature is only available on the web interface.

1. From the home page of the web interface, select **Macros and GPIO**.

- From the list of macros, click **Duplicate** next to the macro you want to copy.



If the limit of 24 macros is reached, the **Duplicate** button is disabled and the **Add Macros** button displays a Limit Reached message.

- In the Name field, enter a meaningful name for the macro.
- Modify the appropriate fields.
- To save the macro, click **Save**.

Editing a macro

Edit the macro if the functionality of the macro has changed.



This feature is only available on the web interface.

- From the home page of the web interface, select **Macros and GPIO**.
- From the list of macros, click **Edit** next to the macro you want to edit.



- Modify the appropriate fields.
- To save the macro, click **Save**.

Deleting a macro

Delete one or more macros if they are no longer relevant.



This feature is only available on the web interface.

- From the home page of the web interface, select **Macros and GPIO**.
- From the list of macros, select one or more macros to delete.
To delete all the macros in the list, click **Select All**. the number of macros you want to delete is displayed next to the trash can.
- Click **Delete**.



- At the confirmation prompt, click **Delete**.

Configuring the GPIO

The Generic Purpose Input Output (GPIO) provides a flexible method of interfacing with external devices to the projector.

The GPIO is configured to automate real time events. Each of the seven pins is defined as either an input or output depending on the required outcome. The remaining two pins are reserved for ground and power.

Configure the pin as an input if you want the projector to respond to something the device does and as an output if you want the external device to respond to an action taken by the projector. For example, configure the pin as an output if you want the lighting in a room to automatically dim when the projector is turned on.



This feature is only available on the web interface.

1. From the home page of the web interface, select **Macros and GPIO**.
2. Select **GPIO Configuration**.
3. In the GPIO Configuration dialog under Update the New Configuration, toggle the pins you want active for the input and output.
A blue pin indicates input and a green pin indicates output.
4. Select **Apply**.

GPIO connector

The GPIO connector located on the input panel provides a flexible method of interfacing with the projector. Seven GPIO pins are available on the nine pin D-Sub GPIO connector. Two other pins are reserved for ground and power.

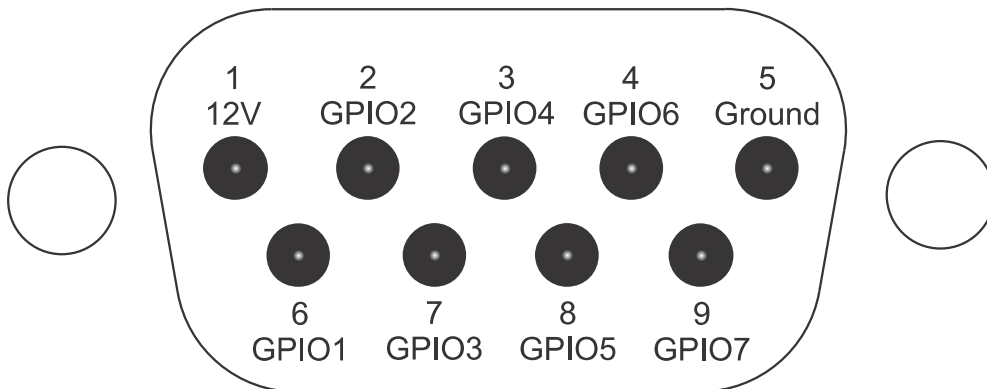

D-SUB pin number	Signal	Output high (Voh)	Notes
Pin 1	+12V	—	1A max
Pin 2	GPIO 2	5V	75mA max (e)fused to prevent damage
Pin 3	GPIO 4		
Pin 4	GPIO 6		
Pin 5	Ground	—	—
Pin 6	GPIO 1	5V	75mA max (e)fused to prevent damage
Pin 7	GPIO 3		
Pin 8	GPIO 5		
Pin 9	GPIO 7		



All GPIO pins are weakly pulled up to 3.3V.

Setting up projector profiles

Use the projector profiles to store configured settings so you can switch between the profiles as required.

Creating a new projector profile

Save the projector configuration to a profile so you can revert to those saved settings any time. You can save up to 10 projector profiles.

1. Configure the projector settings you want to save to the profile.
2. Select **MENU > Admin > Projector Profiles**.
3. Select an empty profile.
4. Next to New Profile, select **Create**.
5. In the dialog, enter a new profile name.
6. Select **Save**.

Importing a projector profile

Import projector profiles set on different projectors using a USB flash drive (projector) or file (web interface).

1. If using the display panel, insert the USB flash drive containing the projector profile file into the USB port on the projector.
2. Select **MENU > Admin > Projector Profiles**.
3. Select an empty profile.
4. Next to Import From File, select **Import**.
5. Select a projector profile file.
 - On the projector, from the File Selection dialog, select a projector profile file.
 - From the web interface, in the Open dialog, navigate to the file and select **Open**.

The projector profile file is imported to the projector.

Restoring settings from a profile

Return the projector to the configuration specified in a specific projector profile.

1. Select **MENU > Admin > Projector Profiles**.

2. Select an existing profile.
3. Select **Restore Profile**.
4. From the Restore dialog, select the settings you want to restore.
5. Select **Restore**.

Renaming a projector profile

A newly created projector profile is given the name of the projector with the date the profile was saved, for example, *<productname>_2020-06-15*. You can change the name of the saved profile to a more meaningful name.

1. Select **MENU > Admin > Projector Profiles**.
2. Select an existing profile.
3. Select **Rename Profile**.
4. Use the up and down keys to enter the new name of the profile.
5. Select **Save**.

Exporting a projector profile to an external device

Save the projector settings to a USB flash drive (projector) or file (web interface).

1. If using the display panel to export a projector profile, insert a USB flash drive (properly formatted as FAT) into the USB port on the projector.
2. Select **MENU > Admin > Projector Profiles**.
3. Selecting an existing profile.
4. Select **Export**.
A default name is assigned.

Deleting a projector profile

If the settings in the projector profile are no longer relevant, delete the profile.

1. Select **MENU > Admin > Projector Profiles**.
2. Select the profile you want to delete.
3. Select **Delete**.
4. At the confirmation prompt, select **Delete**.

Setting up Christie View

Christie View allows up to four different video sources to be displayed on one screen at the same time. The system displays up to four inputs from a single projector simultaneously, which enables multiple viewers to observe up to four different experiences.

When Christie View is enabled the projector ingests up to four different video inputs. Each user views one of the four 2K—2048x1080 (Griffyn Series and Mirage SST)/1920x1080 (Christie M 4K RGB Series)—video sources at 60Hz. Each user views the projected output through a pair of active shutter glasses.

Required components

The following components are required.

Christie View

- Mirage Pro license
- DB9 to mini DIN3 2 m harness

Additional components

- Christie Twist 2.5
- Active shuttered glasses (recommend model: XPAND X105-RF-X1):
 - Two pairs for 4-port, 2-viewer 3D glasses
 - Four pairs for 4-port, 4-viewer 2D glasses
- RF transmitter (recommended model: XPAND AD025-RF-X1)

Video source

- For Mirage SST only, inputs connected into any of the following layouts:
 - [0-1], [0-2], [0-3], [0-4]
 - [1-1], [1-2], [2-1], [2-2]
 - [3-1], [3-2], [4-1], [4-2]
- For Griffyn Series and Christie M 4K 25 Series only, inputs connected to SDI1, SDI2, SDI3, and SDI4
- 2K—2048x1080 (Griffyn Series and Mirage SST)/1920x1080 (Christie M 4K RGB Series)—resolution at 60 Hz required on all inputs



- All sources must be frame synchronous.
- 1920 x 1080 (FHD) image formats are supported.
- 1/1.001 fractional frame rates are supported.

Adding the Mirage Pro software license to the projector

Add the Mirage Pro software license to the projector using Christie Twist 2.5 or higher.

The Mirage Pro license must be installed on the projector for Christie View to function.

1. Record the serial number of the projector(s) and send it to Christie Technical Support requesting the Mirage Pro software license.
The serial number is available on the projector label, from the **Status > Configuration** menu, or you can send the (SST+CONF?1) serial API command.
Christie Technical Support will send zipped license file(s) to you. If you sent more than one serial number, you will receive multiple license files as the .key file is based on the serial number of the projector.
2. Unzip the license file(s) to a known location on your computer.
3. Make sure the projector you want to apply the license to is running and is on the same subnet as your computer.
4. From the Start menu, select **Christie > Twist 2.x > Projector License Utility**.
5. In the Christie Projector License Utility dialog, click **Browse**.
6. Navigate to the location of the unzipped license file (.key) and select the Mirage Pro license.
7. From the Projectors list, select the projector you want to apply the upgrade to.
8. Click **Apply**.
9. Reboot the projector.
10. To verify the license was installed, select **Menu > Admin > Licenses > View**.
11. Repeat steps 3 to 10 for each additional projector.

Setting up Christie View

Follow these steps to connect the Christie View cable to the transmitter(s) and enable the input selection.



Enabling Christie View changes the output resolution of the projector to 2K.

1. Set up the projector and connect to AC power.
Do not turn on the projector.
2. Plug the content source outputs into the projector.
3. Connect the female DB9 end of the Christie View cable into the male GPIO connector on the projector.

4. Connect the RF transmitter(s) into the female mini-DIN3 connectors on the Christie View cable.
5. Enable HFR:
 - a) Select **MENU > Configuration > Input Settings > High Frame Rate**.
 - b) To change to 2K resolution for HFR, select **Enable**.
 - c) At the confirmation prompt, select **Enable**.

The projector reboots and the High Frame Rate button changes to Disable.

Issuing the (OTR <0 | 1>) serial command for the Griffyn Series and Mirage SST also toggles between the 4K and 2K resolutions.
6. Turn on the projector.
7. From the display panel, select **Input Selection > Port Configuration** and select one of the following inputs: **Four-port, 4 Viewer 2D** or **Four-Port, 2 Viewer 3D**.

The port type is displayed in the preview screen of the display panel. All the transmitters should be emitting a red light indicating they are on.

Setting up the glasses

Follow these steps to set up the XPAND Vision glasses to use with Christie View.

If using the XPAND Vision glasses for the first time, they must be paired with the RF emitter(s). If the glasses have already been paired, skip to step 7.

1. Connect the first RF emitter to the mini-DIN3 connector on the Christie View cable labeled A.
Ensure only one emitter is connected to the Christie View cable.
2. Turn on the glasses by pressing the button on the inside of the frame once.
A red LED illuminates indicating the glasses are turned on.
3. Press and hold the button on the inside of the frame for at least one second.
The LED starts blinking at a rate of one blink every two seconds. After the glasses have successfully paired with the RF emitter, the LED blinks six times.
4. For each pair of glasses needing to be paired to the connected RF emitter, repeat steps 2 to 3.
5. When all glasses for view A have been paired, disconnect the RF emitter for view A from the Christie View cable.
Christie recommends the emitter(s) and glasses are labeled for their respective view to avoid confusion during and after setup.
6. Repeat steps 1 to 5 connecting each RF emitter to the cable in descending order (B, C, and then D).
Up to four emitters can be connected.
7. Turn on each pair of glasses by pressing the button on the inside of the frame once.
A red LED illuminates indicating the glasses are turned on. The glasses default to Four-port, 2 Viewer 3D mode. Each lens should be showing a different view.
8. If using Four-port, 4 Viewer 2D mode, double-press the button on the inside of the glasses frame.
The LED blinks once. The same view should now be visible through both lenses.

The glasses are turned off automatically when the projector is powered off or if the input on the projector is changed to a non-Christie View mode. Christie recommends ensuring the glasses are

turned off when not in use to conserve battery life. To turn off the XPAND Vision glasses, press the button on the inside of the frame. A red light flashes once, slowly.

Connection diagrams

The following diagrams illustrate some of the connection possibilities for Christie View.



Frame-locked content sources are required.

Four-port, 4-Viewer 2D (1080p 60 Hz connection)

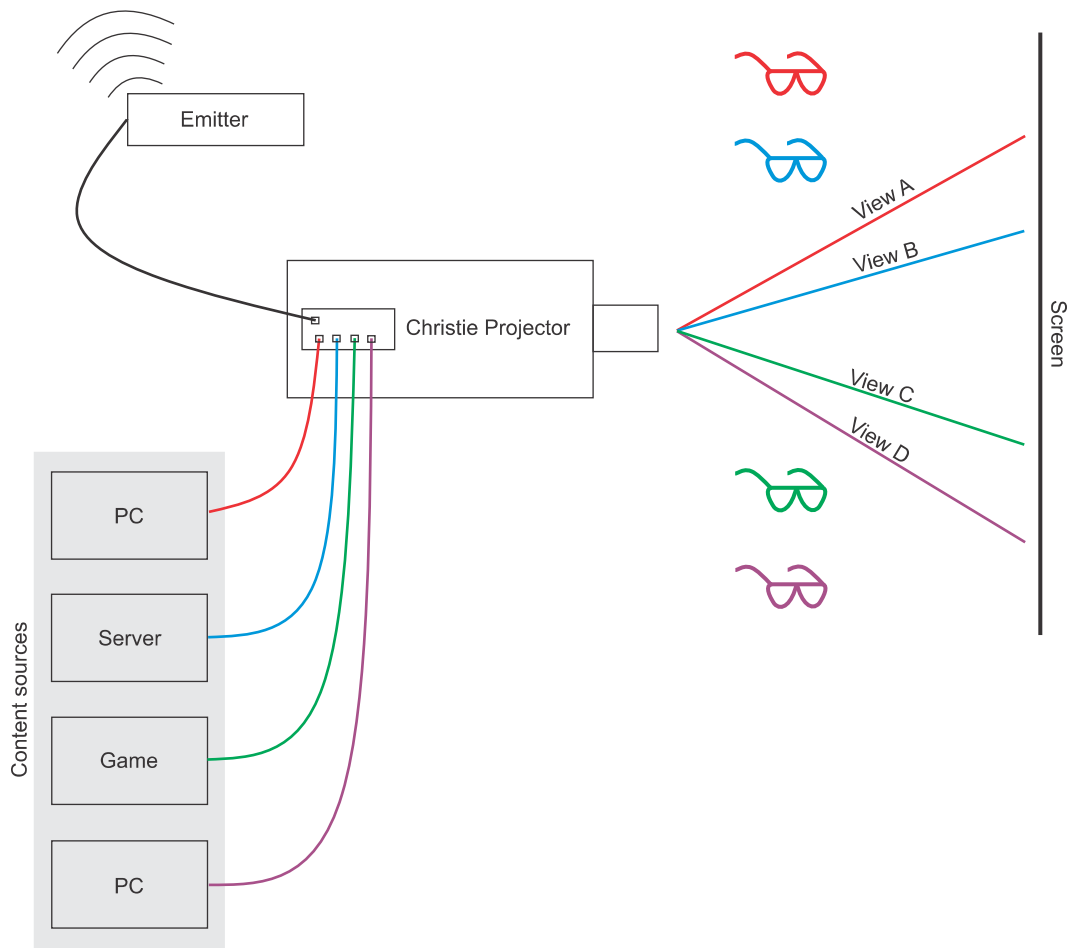

Four-port, 2-Viewer 3D (1080p 120Hz connection)

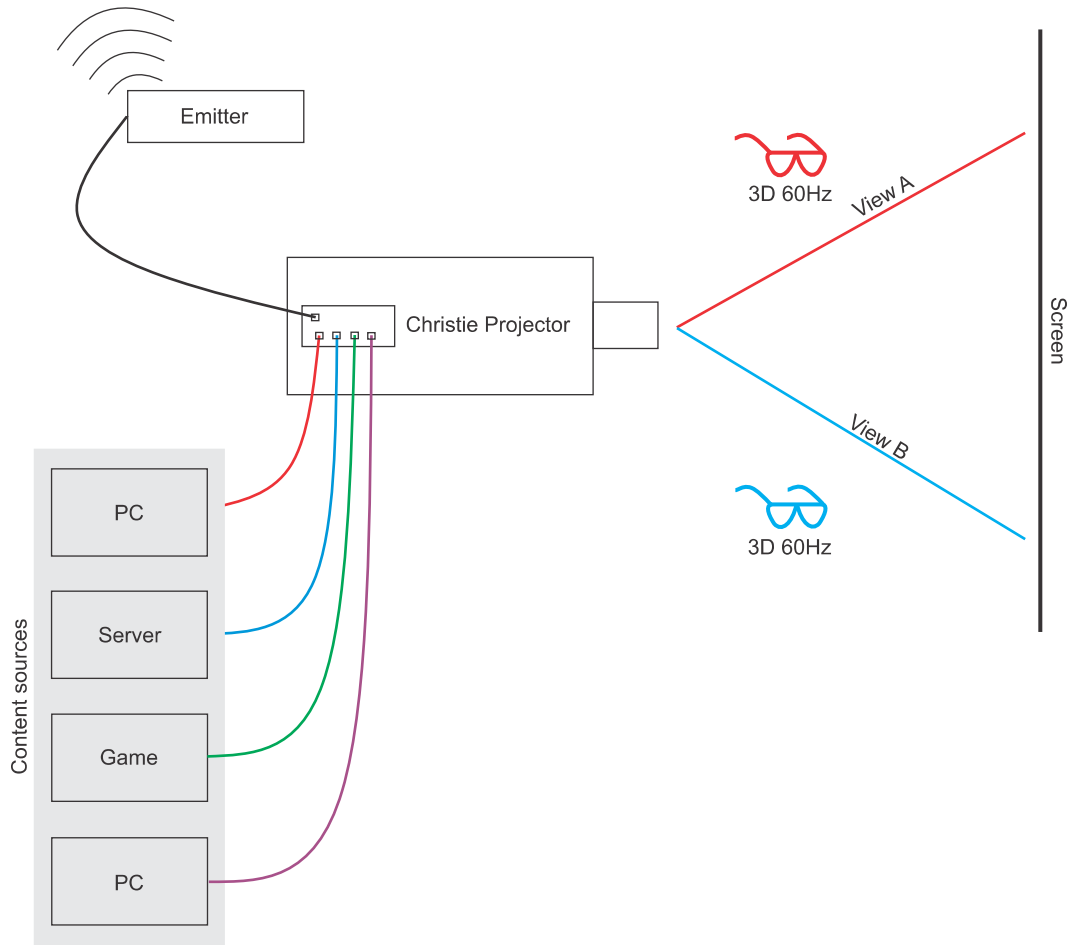

Troubleshooting

For assistance with common issues, refer to the following troubleshooting topics.

Content is not displaying on the screen

The glasses are turned on and functioning but content is not appearing on the screen.

Solution:

1. Make sure the projector is in Christie View mode.
2. Make sure the Christie View cable is seated correctly on the projector and the RF emitter(s) are seated correctly for each mini-DIN3 connector on the cable.

Image tear appearing on the screen

The screen shows a different frame of video than what is shown on the bottom portion of the screen.

Solution: Adjust the frame delay by selecting **MENU > Image Settings > Advanced Image Settings > Frame Delay**.

Multiple views being observed when wearing the glasses

There is a potential for views other than your own to be visible based on brightness and content. This is referred to as ghosting.

Solution: Try to display content close to the same brightness for all views being used. This will help mitigate any ghosting that may occur.

The glasses are turning on and then off again after a few seconds

If the glasses cannot find an RF signal from an emitter within a few seconds, they turn off again.

Solution:

1. Make sure the projector is in Christie View mode.
2. Make sure the Christie View cable is seated correctly on the projector and the RF emitter(s) are seated correctly for each Mini-DIN3 connector on the cable.
3. The glasses may need to be paired again with an RF emitter.

The glasses are not turning on

The battery level for that pair of glasses may be depleted.

Solution: Charge the glasses using a micro USB cable.

The LED on the glasses is blinking every few seconds

The battery level for that pair of glasses is getting low.

Solution: Charge the glasses using a micro USB cable.

Content is being projected as black on the screen

The glasses are turned on and functioning, a Christie View mode is selected, and the content preview can be seen on the projector side panel display; however, content does not appear on the screen.

Solution:

1. Make sure the projector is set to 2K output resolution—2048x1080 (Griffyn Series and Mirage SST)/1920x1080 (Christie M 4K RGB Series)—by selecting **MENU > Status > Configuration > 3. Output Resolution**.
2. If the projector is configured to 4K output resolution (4096 x 2160):
 - a. Select **MENU > Configuration > Input Settings > High Frame Rate**.
 - b. To change to 2K resolution for HFR, select **Enable**.
 - c. At the confirmation prompt, select **Enable**.
The projector reboots and the High Frame Rate button changes to Disable.
Issuing the (OTR <0 | 1>) serial command also toggles between the 4K and 2K resolutions.

Backing up, restoring, and upgrading files

Learn how to back up, restore, and upgrade files.

Upgrading the Mirage SST software

When a new version of the software is released, Mirage SST must be upgraded.

1. Turn off the lasers before proceeding with the upgrade.
2. If using the display panel to upgrade the software, insert a USB key that contains the software upgrade file.
The USB flash drive must be formatted using the FAT 32 file system.
The upgrade file must be located at the root of the USB key.
3. Select **MENU > Admin > Software > Upgrade**.
4. Select an upgrade file.
 - On the projector, select the upgrade file from the root of the USB and select **Enter**.
 - From the web interface, in the Open dialog, navigate to the file and select **Open**.
5. To automatically restart Mirage SST, select **Restart Now**.
If you decide restart Mirage SST at a later date (**Restart Later**), you cannot perform another upgrade until the Mirage SST is restarted.

Adding a software license to a projector

Add the software license to the projector using the Christie Twist 2.5 or higher.

1. Record the serial number of the projector(s) and send it to Christie Technical Support.
The serial number is available on the projector label, from the **Menu > Status > Configuration** menu, or you can send the (SST+CONF?1) serial API command.
Christie Technical Support will send a zipped license file to you. If you sent more than one serial number, you will receive multiple license files as the .key file is based on the serial number of the projector.
2. Unzip the license file to a known location on your computer.
3. Make sure the projector you want to upgrade is running and is on the same subnet as your computer.
4. From the Start menu, select **Christie > Twist 2.x > Projector License Utility**.
5. In the Christie Projector License Utility dialog, click **Browse**.
6. Navigate to the location of the unzipped license file (.key) and select it.

7. From the Projectors list, select the projector you want to apply the upgrade to.
8. Click **Apply**.
9. Reboot the projector.
10. Repeat steps 3 to 9 for each additional projector.

Exporting backup settings to an external device

Save the Mirage SST settings to a USB flash drive (projector) or file (web interface).

1. If using the display panel to export settings, insert a USB flash drive (properly formatted as FAT) into the USB port on Mirage SST.
2. Select **MENU > Admin > Backup & Restore**.
3. Select the backup option.
 - On the projector, select **Backup to USB**.
 - On the web interface, select **Backup to File**.

A default name is assigned.

4. From the projector:
 - a) To edit the backup file name, select the up arrow and select **Enter**.
 - b) To save the name, navigate down and select **SAVE**.
The backup file is exported.
5. From the web interface:
 - a) To edit the backup file name, enter the new name and select **Backup**.
The backup file is created.
 - b) To download the backup file, select **Download**.
The backup file is downloaded to the default location on the computer.

Importing a file from an external device to restore settings

Restore backed up files, stored on a USB flash drive (projector) or file (web interface), onto the projector.

1. If using the display panel to import the file, insert the USB flash drive containing the backup file into the USB port on the projector.
2. Select **MENU > Admin > Backup & Restore**.
3. Select the restore option.
 - On the projector, select **Restore from USB**.
 - On the web interface, select **Restore from File**.
4. Select the file.
 - On the projector, from the File Selection dialog, select a file to restore.
 - From the web interface, in the Open dialog, navigate to the file and select **Open**.

The backup settings file is imported to the projector.

Restoring projector default settings

Restore the Mirage SST settings back to the default values. Network configurations and calibration values are not reset.

From the display panel, select **MENU > Admin > Backup & Restore**.

Diagnostic tools

Follow these procedures to help with diagnosing issues with Mirage SST.

Viewing Mirage SST information

View the licenses for the software added to Mirage SST and the licenses of the software used to operate Mirage SST. The information is read-only.

1. To view the additional software added to Mirage SST, next to **MENU > Admin** and next to Licenses, select **View**.
2. To view the software licenses used to run Mirage SST, select **MENU > Admin** and next to About, select **View**.

Freezing an image

Use the Freeze Image diagnostic tool to examine in detail a still version of an incoming image.

For example, in moving images sometimes it is difficult to observe artifacts such as external de-interlacing/resizing and signal noise.

1. Select **MENU > Admin > Diagnostics**.
2. To enable freezing of an image, select **Freeze Image** and select **Enter**.
3. To return to normal operation, select **Enter** again to clear the checkbox.

Test patterns

Use the available test patterns to assist with configuration of the projector and to diagnose any issues that may occur.

Selecting a test pattern

21 test patterns are available to assist with the configuration of the projector and to diagnose any issues that may occur.

1. From the side panel home page, use the arrows to select **Test Pattern**.
You can also select the test patterns from **MENU > Test Pattern** or **MENU > Admin > Diagnostics > Test Pattern**.
2. Scroll through the list of test patterns.
3. Select the required test pattern.
4. To confirm your selection, select **Enter**.

Modifying grey level test pattern characteristics

Set the level of grey displayed in the full grey test patterns.

1. Select **MENU > Admin > Diagnostics**.
2. Select **Test Pattern**.
3. Select one of the grey test patterns: GREY SCALE 16 or FLAT GREY.
4. Select **Enter**.
5. To change the grey scale of the test pattern, select **Test Pattern Grey Level** and adjust the slider to the value you want.
6. To confirm your selection, select **Enter**.

Modifying ramp test pattern characteristics

Modify the characteristics for the associated ramp video signal test patterns.

1. Select **MENU > Admin > Diagnostics**.
2. Select **Test Pattern**.
3. Select one of the ramp test patterns: RGBW RAMP, HORIZONTAL RAMP, VERTICAL RAMP, or DIAGONAL RAMP.
4. Select **Enter**.
5. To enable movement of the test pattern, select **Test Pattern Ramp Motion** and select **Enter**.
6. To change the slope of the ramp test pattern, select **Test Pattern Ramp Slope** and adjust the slider to the value you want.
7. To confirm your selection, select **Enter**.
8. To change the level of the ramp test pattern, select **Test Pattern Ramp Level** and adjust the slider to the value you want.
9. To confirm your selection, select **Enter**.

Modifying grid test pattern characteristics

Modify the characteristics for the associated grid test patterns.

1. Select **MENU > Admin > Diagnostics**.
2. Select **Test Pattern**.
3. Select one of the grid test patterns: SQUARE GRID or DIAGONAL GRID.
4. Select **Enter**.
5. To change the pitch of the grid test pattern, select **Test Pattern Grid Pitch** and adjust the slider to the value you want.
6. To confirm your selection, select **Enter**.
7. To change the color of the grid, select **Test Pattern Grid Color** and select **Enter**.
8. To enable movement of the test pattern, select **Test Pattern Grid Motion** and select **Enter**.

Enabling a specific test pattern color

You can enable a specific test pattern color to eliminate one or more colors to help with certain diagnostics and setups, such as overlaying one image on top of another from stacked projectors.

1. From the side panel home page, use the arrows to select **Test Pattern**.
You can also select the test patterns from **MENU > Test Pattern**.
2. Select the **Flat White** test pattern.
3. To confirm your selection, select **Enter**.
4. On the IR remote keypad, press **Func+6+<0 to 7>**.
Where <0 to 7> represents a specific color.

Selecting an engine test pattern

Several engine test patterns are available to assist with the calibration and internal optical alignments of the projector and to diagnose any issues that may occur.

1. Select **MENU > Admin > Diagnostics > Test Pattern > Engine Test Patterns**.
2. Scroll through the list of test patterns.
3. Select the required test pattern.
4. To confirm your selection, select **Enter**.
5. To disable the engine test patterns, select **MENU > Admin > Diagnostics > Test Pattern > Engine Test Patterns > Off**.
6. To disable the engine test patterns, select **MENU > Admin > Service > Engine Test Patterns > Off**.

Viewing Mirage SST status

Alarms contain information about the values of the items operating in normal range, warnings, and errors that can be reported by the status system of Mirage SST.

1. From the display panel, select **Status**.
You can also view the statuses from **MENU > STATUS**.
2. Scroll to the status category you want to view and select it.

Running the Mirage SST interrogator

The interrogator captures diagnostic information Christie personnel uses to help diagnose and correct any issues.

1. If saving the interrogator file to a USB flash drive on the projector, insert a USB flash drive in the USB port on Mirage SST.
The USB flash drive must be formatted using the FAT 32 file system.
2. Select **MENU > Admin > Interrogator**.
3. Select **Run**.
 - If on the projector, the interrogator file is stored at the root directory on the USB flash drive.

- If running Mirage SST interrogator from the web interface, a message appears indicating the interrogator file was successfully created.
4. From the web interface to download the interrogator file to the computer, select **Download File**.
The interrogator file is downloaded to the default location on the computer.
 5. If on the projector, at the completion prompt, select **OK**.

Identifying where alarm and trap messages are sent

Configure the email address and SNMP trap destination where alarms are recorded.

Creating a distribution mailing list for SNMP alerts means that changes to the people receiving the emails does not require a change to the MIB browser configuration.

Setting the SNMP read community string

The SNMP read community string is similar to a userid or password that allows access to the device.

1. Select **MENU > Communications > SNMP > SNMP Read Community**.
2. Enter the read community string.
On the display panel use the up and down arrows to enter the read community string.
3. To confirm the name of the string, select **Enter**.

Configuring traps

A trap is a condition that SNMP monitors on Mirage SST.

1. Select **MENU > Communications > SNMP > Trap Configuration**.
2. Select the trap you want to enable and select **Enter**.
The available traps are:
 - Fan Stall
 - Thermal Sensors
 - Power
 - Video Signal
3. To enable additional traps, repeat step 2.

Defining a trap IP address

When a trap condition is met, a notification is sent using an SNMP notification to one or more specified IP addresses.

1. Select **MENU > Communications > SNMP**.
2. From the projector:
 - a) Select **Address 1**.
 - b) Use the up and down arrows to enter an IP address.

- c) To confirm the address, select **Enter**.
- d) To add a second and third IP address, repeat steps a to c for **Address 2** and **Address 3**.
3. From the web interface:
 - a) For Address 1, select **Edit**.
 - b) Enter the IP address.
 - c) Select **Apply**.
 - d) To add a second and third IP address, repeat steps a to c for **Address 2** and **Address 3**.

Downloading the SNMP MIB files

The SNMP management information base (MIB) files describe the data format used by SNMP.

1. Select **MENU > Communications > SNMP**.
2. To download the SNMP MIB files, select **Download File**.
The files are downloaded to the default location on the computer.

Restoring factory default settings

Restoring factory settings removes all custom device settings.

Only Christie qualified technicians can reset factory defaults.

1. From the display panel, select **MENU > Admin > Service**.
2. Enter the service password.
The password is only required for the display panel and not the web user interface.
3. Select **Reset Factory Defaults**.
All customized settings are set to the default factory settings.
4. At the confirmation prompt, select **Reset**.

Regulatory

This product conforms to the latest regulations and standards related to product safety, environmental, and electromagnetic compatibility (EMC) requirements.

Safety

- ANSI/UL 60950-1 – Information Technology Equipment – Safety – Part 1: General Requirements
- CAN/CSA C22.2 No. 60950-1-07 – Information Technology Equipment – Safety – Part 1: General Requirements
- IEC/EN 60825-1 – Safety of Laser Products – Part 1: Equipment Classification and Requirements
- IEC/EN 60950-1 – Information Technology Equipment – Safety – Part 1: General Requirements
- IEC/EN 62471-5 – Photobiological Safety of Lamps and Lamp Systems – Part 5: Image projectors

Electro-magnetic compatibility

Emissions

- CAN ICES-003 (A)/NMB-003 (A) – Information Technology Equipment (Including Digital Apparatus) – Limits and Methods of Measurement
- CISPR 32/EN 55032, Class A – Electromagnetic Compatibility of Multimedia Equipment – Emission Requirements
- FCC CFR47, Part 15, Subpart B, Class A – Unintentional Radiators
- IEC 61000-3-2/EN61000-3-2: Limits for harmonic current emissions for equipment with input current ≤ 16 A
- IEC 61000-3-3/EN61000-3-3: Limitations of Voltage Changes, Voltage Fluctuations, and Flicker input current ≤ 16 A

Immunity

- CISPR 24/EN55024 EMC Requirements – Information Technology Equipment

Environmental

- China Ministry of Information Industry (along with 7 other Government Agencies) Order No.32 (01/2016) on the control of pollution caused by electronic information products, hazardous

substances concentration limits (GB/T 26572 - 2011), and the applicable product marking requirement (SJ/T 11364 - 2014).

- EU Directive (2011/65/EU) on the restriction of the uses of certain hazardous substances (RoHS) in electrical and electronic equipment and the applicable official amendment(s).
- EU Directive (2012/19/EU) on waste and electrical and electronic equipment (WEEE) and the applicable official amendment(s).
- Regulation (EC) No. 1907/2006 on the registration, evaluation, authorization and restriction of chemicals (REACH) and the applicable official amendment(s).

