The top half of the page features a complex, abstract background of overlapping, semi-transparent blue triangles and polygons, creating a faceted, crystalline effect. The colors range from light sky blue to deep navy blue. A white diagonal line separates this patterned area from the plain white background below.

Installation and Setup Guide
020-103014-06

Mirage 4K40-RGB

CHRISTIE®

NOTICES

COPYRIGHT AND TRADEMARKS

Copyright © 2022 Christie Digital Systems USA Inc. All rights reserved.

All brand names and product names are trademarks, registered trademarks or trade names of their respective holders.

GENERAL

Every effort has been made to ensure accuracy, however in some cases changes in the products or availability could occur which may not be reflected in this document. Christie reserves the right to make changes to specifications at any time without notice. Performance specifications are typical, but may vary depending on conditions beyond Christie's control such as maintenance of the product in proper working conditions. Performance specifications are based on information available at the time of printing. Christie makes no warranty of any kind with regard to this material, including, but not limited to, implied warranties of fitness for a particular purpose. Christie will not be liable for errors contained herein or for incidental or consequential damages in connection with the performance or use of this material. Our centers of excellence for manufacturing in Kitchener, Ontario, Canada and in Shenzhen, China are ISO 9001:2015 Quality Management System-certified.

For the most current technical documentation and office contact information, visit <http://www.christiedigital.com>.

Warranty

Products are warranted under Christie's standard limited warranty, the details of which are available at <https://www.christiedigital.com/help-center/warranties/> or by contacting your Christie dealer or Christie.

PREVENTATIVE MAINTENANCE

Preventative maintenance is an important part of the continued and proper operation of your product. Failure to perform maintenance as required, and in accordance with the maintenance schedule specified by Christie, will void the warranty.

REGULATORY

The product has been tested and found to comply with the limits for a Class A digital device, pursuant to Part 15 of the FCC Rules. These limits are designed to provide reasonable protection against harmful interference when the product is operated in a commercial environment. The product generates, uses, and can radiate radio frequency energy and, if not installed and used in accordance with the instruction manual, may cause harmful interference to radio communications. Operation of the product in a residential area is likely to cause harmful interference in which case the user will be required to correct the interference at the user's own expense. Changes or modifications not expressly approved by the party responsible for compliance could void the user's authority to operate the equipment

CAN ICES-3 (A) / NMB-3 (A)

이 기기는 업무용(A급)으로 전자파적합등록을 한 기기이오니 판매자 또는 사용자는 이점을 주의하시기 바라며, 가정 외의 지역에서 사용하는 것을 목적으로 합니다.

ENVIRONMENTAL



The product is designed and manufactured with high-quality materials and components that can be recycled and reused. This symbol  means that electrical and electronic equipment, at their end-of-life, should be disposed of separately from regular waste. Please dispose of the product appropriately and according to local regulations. In the European Union, there are separate collection systems for used electrical and electronic products.

If printing this document, consider printing only the pages you need and select the double-sided option.

Please help us to conserve the environment we live in!

Content

Introduction.	6
Safety and warning guidelines.	6
Installation safety and warning guidelines.	7
AC power precautions.	7
Laser safety precautions.	8
Light intensity hazard distance.	8
Product labels.	11
Projector overview.	13
Contact your dealer.	14
Key features.	14
List of components.	14
Product documentation.	15
Related documentation.	15
Technical support.	15
Installation and setup.	17
Site requirements.	17
Projector components.	18
Display panel components.	19
IR/wired remote keypad.	20
Required tools.	21
Preparing the installation site.	22
Lifting and positioning the projector.	22
Leveling the projector.	22
Installing the projector lens.	23
Calibrating the lens motor.	25
Removing the projection lens.	26
Installing the ultra short throw projector lens.	26
Connecting to AC power.	28
Turning on the projector.	28
Projector LED status indicators.	29
Projector LED shutter indicators.	29
Turning off the projector.	30
Aligning the image.	30

Adjusting offset.	30
Resetting the lens to home position.	31
Selecting a test pattern.	31
Adjusting boresight.	31
Optimizing the integrator zoom and focus.	33
Adjusting the fold mirror.	35
Mechanically adjusting DMD convergence.	36
Aligning the image with lens zoom and focus.	38
Running Auto Setup to optimize display settings.	39
Configuring Mirage 4K40-RGB to work with Christie Link.	39
Completing the installation checklist.	39
Connecting devices and establishing communication.	40
IMXB ports.	40
Connecting a video source using 3G input card.	41
Connecting a video source using DVI.	42
Connecting a video source using DisplayPort.	42
Connecting a video source using HDMI.	43
Connecting a video source using HBMIC.	44
Connecting a video source using TSIC.	45
Connecting a video source using HDBaseT.	45
Selecting a video source.	46
Connecting to a computer or server.	46
Configuring the RS232 port.	46
Setting up the Ethernet.	47
3D setup.	48
3D requirements.	48
Hardware requirements.	48
Software and content requirements.	48
Active stereo 3D configuration.	49
Passive stereo 3D configuration.	49
3D system timing.	50
3D input video configurations.	50
Setting up a single projector to display 3D content.	50
Enabling 3D mode.	50
Confirming the emitter setup.	51
Configuring the projector for the 3D source.	51
Connecting devices to the 3D sync ports.	51

Signal connectivity specifications for Mirage 4K40-RGB. 52

- HBMIC video formats. 52
- TSIC video formats. 54
- TDPIC video formats. 54
- DDIC video formats. 55
- THIC video formats. 56
- 3GIC video formats. 56
- HDBase-T video formats. 57
- Dual-input 3D. 57

Regulatory. 61

- Safety. 61
- Electro-magnetic compatibility. 61
 - Emissions. 61
 - Immunity. 61
- Environmental. 61

Introduction

This manual is intended for professionally trained operators of Christie high-brightness projection systems.



The illustrations in this document are for representation only and may not depict your projector model exactly.

Only Christie qualified technicians who are knowledgeable about the hazards associated with laser use, high-voltage, and the high temperatures generated by the projector lasers are authorized to assemble, install, and service the projector.

For complete Mirage 4K40-RGB product documentation and technical support, go to www.christiedigital.com.

Safety and warning guidelines

Read all safety and warning guidelines before installing or operating the projector.

This projector is intended for use in a non-cinema environment.

This projector must be operated in an environment that meets the operating range specification. Use only the attachments and/or accessories recommended by Christie. Use of others may result in the risk of fire, shock, or personal injury.



Warning! If not avoided, the following could result in death or serious injury.

- This product must be operated in an environment that meets the operating range as specified in this document.
- Do not look directly into the lens when the light source is on. The extremely high brightness can cause permanent eye damage.
- **EXTREME BRIGHTNESS!** When accessing a restricted access location for product service or maintenance, avoid exposure to the product beam path by turning the product power off and disconnecting the product from AC power, or by shuttering the light source to avoid emissions from the front aperture.
- **FIRE HAZARD!** Keep hands, clothes, and all combustible material away from the concentrated light beam of the projector.
- Keep fingers and other body parts away from the moving parts in the product. Tie back long hair, and remove jewelry and loose clothing before manually adjusting the product.
- **FIRE AND SHOCK HAZARD!** Use only the attachments, accessories, tools, and replacement parts specified by Christie.
- Do not operate the product without a lens installed.
- Always use a lens plug when installing or moving the product. This prevents contaminants from entering the product.
- **RADIATION HAZARD!** Use of controls or adjustments, or performing procedures other than those specified may result in hazardous radiation exposure.



Caution! If not avoided, the following could result in minor or moderate injury.

- TRIP OR FIRE HAZARD! Position all cables where they cannot contact hot surfaces, be pulled, be tripped over, or damaged by persons walking on or objects rolling over the cables.

Installation safety and warning guidelines

Read all safety and warning guidelines before installing the projector.



Warning! If not avoided, the following could result in death or serious injury.

- Possible hazardous optical radiation emitted from this product. (Risk group 3)
- High leakage current present when connected to IT power systems.
- Christie products must be installed and serviced by Christie qualified technicians.
- Do not operate the product without all of its covers in place.
- A minimum of four people or appropriately rated lift equipment is required to safely lift, install, or move the product.
- Always install safety straps when the frame and projector are installed overhead.
- Observe load ratings and applicable local safety codes.
- When installing the projector in portrait mode, the rigging device must have a sufficient load rating, as identified in this manual.
-
- This product must be installed within a restricted access location not accessible by the general public.
- Install the product so users and the audience cannot enter the restricted area at eye level.
- Only personnel who are trained on the precautions for the restricted access location can be granted entry to the area.
- Only Christie qualified technicians are permitted to open product enclosures.



Caution! If not avoided, the following could result in minor or moderate injury.

- ELECTRICAL and BURN HAZARD! Use caution when accessing internal components.
- Only Christie qualified technicians are authorized to use the tools provided in the toolbox.

AC power precautions

Read all safety and warning guidelines before connecting to AC power.



Warning! If not avoided, the following could result in death or serious injury.

- SHOCK HAZARD! Only use the AC power cord provided with the product or recommended by Christie.
- FIRE AND SHOCK HAZARD! Do not attempt operation unless the power cord, power socket, and power plug meet the appropriate local rating standards.
- SHOCK HAZARD! Do not attempt operation if the AC supply is not within the specified voltage and current, as specified on the license label.
- SHOCK HAZARD! The AC power cord must be inserted into an outlet with grounding.
- SHOCK HAZARD! Disconnect the product from AC before installing, moving, servicing, cleaning, removing components, or opening any enclosure.
- Install the product near an easily accessible AC receptacle.



Caution! If not avoided, the following could result in minor or moderate injury.

- FIRE HAZARD! Do not use a power cord, harness, or cable that appears damaged.
- FIRE OR SHOCK HAZARD! Do not overload power outlets and extension cords.
- SHOCK HAZARD! Power supply uses double pole/neutral fusing.

Laser safety precautions

Read all safety and warning guidelines before operating the projector laser.



Warning! If not avoided, the following could result in death or serious injury.

- PERMANENT/TEMPORARY BLINDNESS HAZARD! No direct exposure to the beam must be permitted. Class 1 Laser Product - Risk Group 3 according to IEC 60825-1:2014 and IEC 62471-5:2015.
- LASER RADIATION HAZARD! This projector has a built-in Class 4 laser module. Never attempt to disassemble or modify the laser module.
- Possible hazardous optical radiation emitted from this product. (Risk group 3)
- Only Christie qualified technicians who are knowledgeable about the hazards associated with laser use, high-voltage, and high temperatures generated by the product are authorized to assemble, install, and service the Christie Laser Projection System.
- Do not look directly into the lens when the light source is on. The extremely high brightness can cause permanent eye damage.
- Do not operate the product without all of its covers in place.

Light intensity hazard distance

This projector has been classified as Risk Group 3 as per the IEC 62471-5:2015 standard due to possible hazardous optical and thermal radiation being emitted.



Warning! If not avoided, the following could result in serious injury.

- PERMANENT/TEMPORARY BLINDNESS HAZARD! No direct exposure to the beam must be permitted. Class 1 Laser Product - Risk Group 3 according to IEC 60825-1:2014 and IEC 62471-5:2015.
- PERMANENT/TEMPORARY BLINDNESS HAZARD! Operators must control access to the beam within the hazard distance or install the product at the height that prevents exposure of spectators' eyes within the hazard distance. The hazard zone must be no lower than 3.0 meters above the floor and the horizontal clearance to the hazard zone must be a minimum 2.5 meters.
- EXTREME BRIGHTNESS! Do not place reflective objects in the product light path.

The following show the zones for ocular and skin hazard distances.

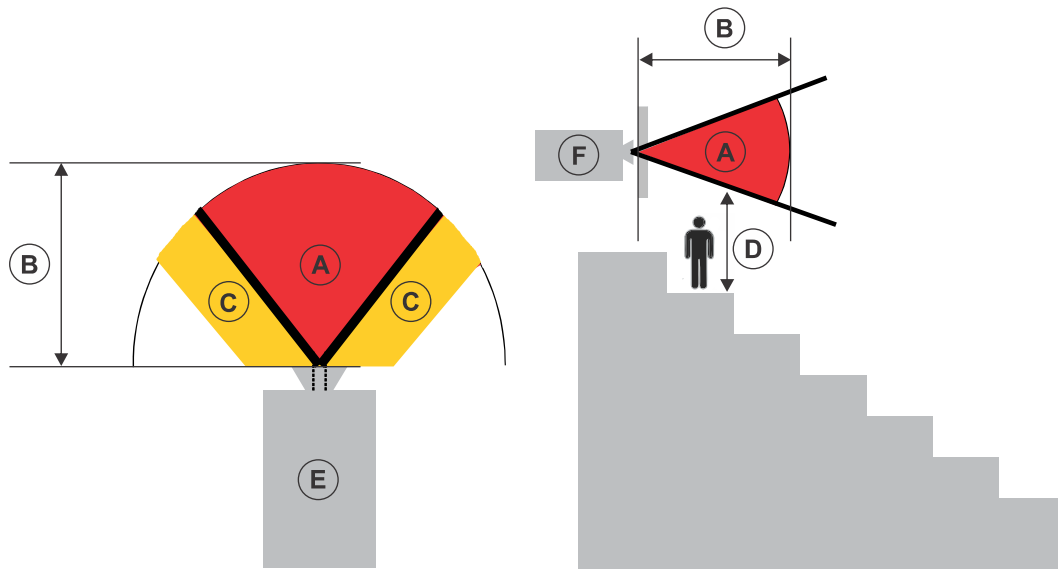

- A—Hazard zone. The region of space where the projection light from the laser-illuminated projector is above emission limits for Risk Group 2. The light intensity may cause eye damage after a momentary or brief exposure (before a person can avert his or her eyes away from the light source). The light may cause skin burns to occur.
- B—Hazard distance. Operators must control access to the beam within the hazard distance or install the product preventing potential exposure of the spectators' eyes from being in the hazard distance.
- C—No access zone. Horizontal clearance of the no access zone must be a minimum of 2.5 meters.
- D—Vertical distance to hazard zone. The hazard zone must be no lower than 3.0 meters above the floor.
If the vertical distance to hazard zone requirement (Zone D) is satisfied, the horizontal clearance distance (Zone C) is not needed.
- E—Represents the top view of the projector.
- F—Represents the side view of the projector.

The following table lists the hazard distance for the Christie projector lens with the zoom adjusted to its most hazardous position.

For US and international hazard distances based upon IEC 62471-5:2015, *Photobiological Safety of Lamps and Lamp Systems – Part 5: Image Projectors*.

Projection lens	Part number	Hazard distance (m)
0.38:1 HB fixed	144-136101-XX	1.0
0.72:1 HB fixed	144-110103-XX	1.0
0.9:1 HB fixed	144-111014-XX	1.0
1.13-1.31:1 HB zoom (Discontinued)	144-103105-XX	1.0
1.13-1.66:1 HB zoom	144-129103-XX	2.0
1.31-1.63:1 HB zoom	144-104106-XX	2.0

Projection lens	Part number	Hazard distance (m)
1.45-2.17:1 HB zoom	144-130105-XX	2.5
1.63-2.17:1 HB zoom (Discontinued)	144-105107-XX	2.5
1.95-3.26:1 HB zoom	144-131106-XX	4.0
1.99-2.71:1 HB zoom	144-106108-XX	3.0
2.71-3.89:1 HB zoom	144-107109-XX	4.5
3.89-5.43:1 HB zoom	144-108100-XX	6.5
0.72:1 UHC fixed	163-116109-XX	1.0
0.9:1 UHC fixed	163-117100-XX	1.0
1.13-1.66:1 UHC zoom	163-118101-XX	2.0
1.45-2.17:1 UHC zoom	163-119102-XX	2.5
1.95-3.26:1 UHC zoom	163-120103-XX	3.5
2.71-3.89:1 UHC zoom	163-121105-XX	4.6
3.89-5.43:1 UHC zoom	163-122106-XX	6.6

For Installations in the United States

The following must be in place for laser-illuminated projector installations in the United States:

- Any human access to the hazard zone, if applicable, must be restricted by barriers to enforce the no access zone.
- Permanent show installations containing Risk Group 3 laser-illuminated projectors must meet the following conditions:
 - Installed by Christie or by Christie-authorized and trained installers. Refer to the EXTERNAL - Laser safety awareness training (Course code: CS-ELSA-01) on the <http://www.christieuniversity.com> site.
 - Performed according to instructions provided by Christie.
 - Make sure the projection system is securely mounted or immobilized to prevent unintended movement or misalignment of the projections.
- A copy of the FDA variance approval letter must be with the operator or other responsible individual.
- Temporary show installations containing Risk Group 3 laser-illuminated projectors may be installed by Christie or sold or leased only to valid laser light show variance holders (laser light show manufacturers) for image projection applications. Such manufacturers may currently hold a valid variance for production of Class IIIb and IV laser light shows and/or for incorporation of the Risk Group 3 laser-illuminated projectors into their shows. This requirement applies also to dealers and distributors of these laser-illuminated projectors.
- For temporary installations, the FDA variance holder must maintain complete records of all show itineraries with dates, locations, operator name, and contact information clearly and completely identified.



- The Christie Laser Projection System Installation Checklist must be fully completed after the installation and sent to *lasercompliance@christiedigital.com*. A copy can remain on-site. This checklist can be found as a separate document in the accessory box with the manual.
- Certain US states have additional laser regulatory requirements. Contact *lasercompliance@christiedigital.com* for additional regulatory requirements.

Product labels

Learn about the labels that may be used on the product. Labels on your product may be yellow or black and white.

General hazards

Hazard warnings also apply to accessories once they are installed in a Christie product that is connected to power.

Fire and Shock Hazard	
 	<p>To prevent fire or shock hazards, do not expose this product to rain or moisture.</p> <p>Do not alter the power plug, overload the power outlet, or use it with extension cords.</p> <p>Do not remove the product enclosure.</p> <p>Only Christie qualified technicians are authorized to service the product.</p>
Electrical Hazard	
	<p>Risk of electric shock.</p> <p>Do not remove the product enclosure.</p> <p>Only Christie qualified technicians are authorized to service the product.</p>



Warning! If not avoided, the following could result in death or serious injury.



Electric shock hazard. To avoid personal injury, disconnect all power sources before performing maintenance or service.



Electrocution hazard. To avoid personal injury, always disconnect all power sources before performing maintenance or service procedures.



Optical radiation hazard. To avoid personal injury, never look directly at the light source.



Voltage hazard. To avoid personal injury, always disconnect all power sources before performing maintenance or service procedures.



Caution! If not avoided, the following could result in minor or moderate injury.



Hot surface hazard. To avoid personal injury, allow the product to cool for the recommended cool down time before touching or handling for maintenance or service.



Burn hazard. To avoid personal injury, allow the product to cool for the recommended cool down time before handling for maintenance or service.



Moving parts hazard. To avoid personal injury, keep hands clear and loose clothing tied back.



Moving fan blades. To avoid personal injury, keep hands clear and loose clothing tied back. Always disconnect all power sources before performing maintenance or service procedures.



Notice. If not avoided, the following could result in property damage.



General hazard.



Not for household use.

Mandatory action



Caution! If not avoided, the following could result in minor or moderate injury.



SHOCK HAZARD! Disconnect all power sources before performing maintenance or service procedures.



Consult the service manual.

Electrical labels



Indicates the presence of a protective earth ground.

Laser labels



CLASS 1 LASER PRODUCT IEC 60825-1

Christie Digital Systems Canada
 809 Wellington Street North
 Richmond Hill, ON L4B 4T7, Canada
 This product conforms with performance standards for laser products under 21 CFR Part 1040 except with respect to those characteristics authorized by Variance Number YYY-4-### effective on Month DD, YYYY. U.S.A. Only

FDA laser variance (US projectors only)

This product conforms with performance standards for laser products under 21 CFR Part 1040 except with respect to those characteristics authorized by Variance Number 2018-V-3898 effective on November 21, 2018.

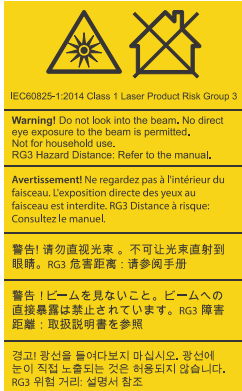

Indicates a light hazard. Do not look directly into the lens. The extreme high brightness can cause permanent eye damage. Class 1 Laser Product - Risk Group 3 according to IEC 60825-1: 2014 and IEC 62471-5:2015



Indicates Class 4 laser radiation when open. Avoid eye or skin exposure to direct or scattered radiation.

Additional safety hazards

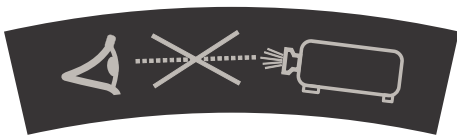

Do not look directly into the lens. The extremely high brightness can cause permanent eye damage.



Indicates high leakage current. Earth connection essential before connecting the power supply.

Projector overview

Learn about the Mirage 4K40-RGB projector.

Mirage 4K40-RGB is a professional quality, easy-to-use 3DLP® RGB laser projector. The high-brightness Mirage 4K40-RGB is designed to meet the special demands found in large venues, live events, and high-usage environments. With reliable Christie Reallaser™ illumination integrated in a rugged chassis and ultra-fast processing of Christie TruLife+™ electronics, the Mirage 4K40-RGB is the go-to solution for demanding, large venue events and applications.

Contact your dealer

Record the information about your projector and keep this information with your records to assist with the servicing of your projector. If you encounter a problem with your Christie projector, contact your dealer.

Purchase record	
Dealer:	
Dealer or Christie Sales/Service contact phone number:	
Projector serial number: The serial number can be found on the license label located on the display panel	
Purchase date:	
Installation date:	
Ethernet settings	
Default gateway:	
Projector IP address:	
Subnet mask:	

Key features

Understand the important features of the projector.

- Long lasting, reliable Christie RealLaser™ RGB laser illumination
- Compact form with direct-coupled laser source integrated into the projector chassis
- LiteLOC™ color lock feature for constant image brightness and color
- Omnidirectional operation for unrestricted design and installation flexibility
- Christie TruLife™ electronics for ultra-high resolution, high frame rate video up to 120 frames per second
- Christie Terra input card integrates into SDVoE networks
- Compatible with most Christie Boxer lenses
- Full-color LCD display to provide information at-a-glance
- Integrated keypad control interface

List of components

Verify all components were received with the projector.

- Power cord
- IR remote keypad
- Network cable
- Tools

- Fiber optic support
- Laser illumination source J33 terminal block 1 (P/N: 001-114198-XX)
- Fiber connector safety cover

Product documentation

For installation, setup, and user information, see the product documentation available on the Christie website. Read all instructions before using or servicing this product.

1. Access the documentation from the Christie website:
 - Go to this URL: <https://bit.ly/33JIojF> or <https://www.christiedigital.com/products/projectors/all-projectors/4K40-RGB-series/christie-d4k40-rgb/overview>.
 - Scan the QR code using a QR code reader app on a smartphone or tablet.



2. On the product page, select the model and switch to the **Downloads** tab.

Related documentation

Additional information on this product is available in the following documents.

- *4K40-RGB Product Safety Guide (P/N: 020-102957-XX)*
- *Mirage 4K40-RGB User Guide (P/N: 020-103015-XX)*
- *Mirage 4K40-RGB Specifications Guide (P/N: 020-103016-XX)*
- *Mirage 4K40-RGB Status System Guide (P/N: 020-103030-XX)*
- *Mirage 4K40-RGB Serial Commands Guide (P/N: 020-103028-XX)*
- *4K40-RGB Service Guide (P/N: 020-102960-XX)*

Technical support

Technical support for Christie Enterprise products is available at:

- North and South America: +1-800-221-8025 or Support.Americas@christiedigital.com
- Europe, Middle East, and Africa: +44 (0) 1189 778111 or Support.EMEA@christiedigital.com
- Asia Pacific (support.apac@christiedigital.com):
 - Australia: +61 (0)7 3624 4888 or tech-Australia@christiedigital.com
 - China: +86 10 6561 0240 or tech-supportChina@christiedigital.com
 - India: +91 (80) 6708 9999 or tech-India@christiedigital.com
 - Japan: 81-3-3599-7481

- Singapore: +65 6877-8737 or *tech-Singapore@christiedigital.com*
- South Korea: +82 2 702 1601 or *tech-Korea@christiedigital.com*
- Christie Professional Services: +1-800-550-3061 or *NOC@christiedigital.com*

Installation and setup

Learn how to install, connect, and optimize the projector display.

Site requirements

To safely install and operate the Mirage 4K40-RGB, the installation location must meet these minimum requirements.

Physical operating environment

- Humidity (non-condensing) 10% to 80%

External exhaust ducting

Sufficient ventilation is required around the projector to regulate the temperature of the internal laser module. If necessary, air intake and exhaust HVAC ducts can be installed.

An exhaust duct is also available for purchase as an optional accessory (P/N: 163-102104-XX). Instructions for installing the exhaust duct are included with the accessory part.

The installation site must provide an airflow 450 cubic feet per minute (CFM) at 1 to 1000 meters elevation, and must accommodate a heat load of 4 kW.

Power connection

Connect to AC power using the power cord provided with the projector.

A certified wall breaker is required as part of the installation. The breaker must be part of the building and easily accessible. The size of the breaker is determined from the power requirements of the projector and can be up to 30A maximum.

Projector components

Identify the main components of the projector.

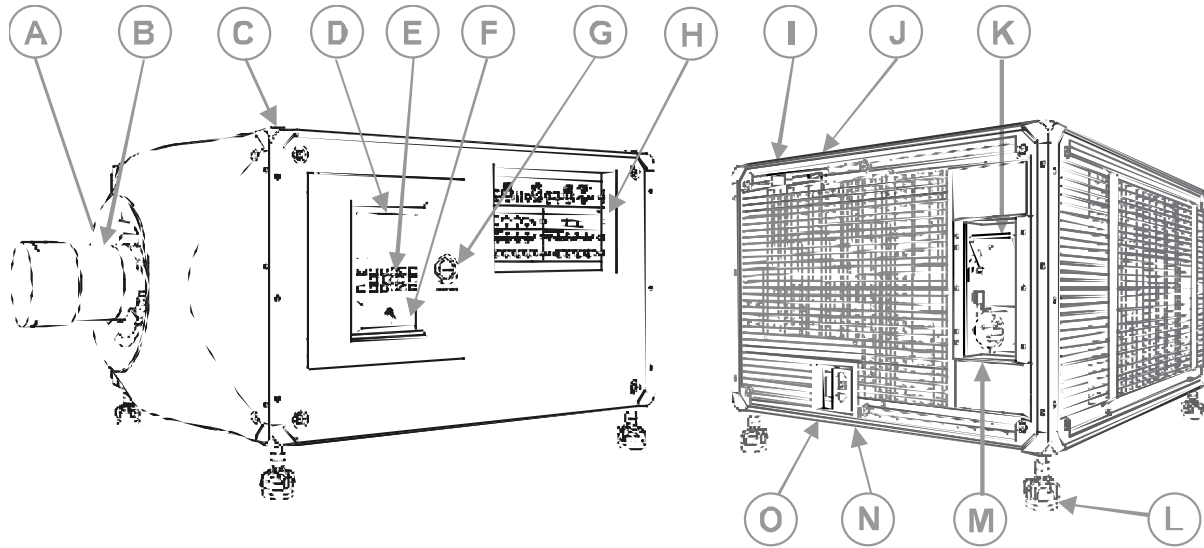

ID	Component	Description
A	Front IR	Receives transmissions from the IR remote.
B	Projection lens	A variety of lenses can be used with the projector. Available lenses are listed in the <i>Mirage 4K40-RGB Specifications Guide (P/N: 020-103016-XX)</i>
C	Mounting and rigging holes	M12 x 1.75 holes for projector feet installation and for mounting and rigging points. Four holes located on the top, and four located on the bottom.
D	Display panel	Displays the projector menus and status.
E	Keypad interface	Controls the projector.
F	Christie TAP	Enables Android devices to communicate with the projector using near field communication.
G	Tool box	Provides tools for Christie qualified technicians.
H	Communication and input panel	Connects media sources to either the ports on the option cards or the IMXB
I	Rear IR	Receives transmissions from the IR remote.
J	LED and shutter LED status indicator	Indicates power status and shutter status.
K	Power cord retainer clamp	For stabilizing and protecting the power cord.
L	Adjustable feet	Raise or lower these feet when positioning the projector. Make sure the projector is level on all sides and the displayed image appears rectangular without any keystone.
M	AC input	For use with projector power cord.
N	Breaker switch	Circuit breaker switch to shut off AC power.

ID	Component	Description
O	Power on/off switch	Switch to power the projector on or off.

Display panel components

Identify the main components of the display panel (also known as the home page).

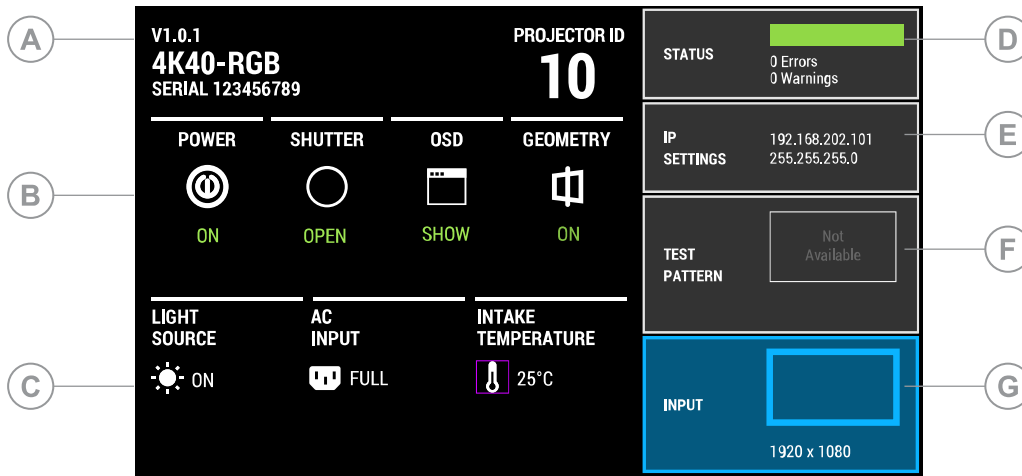

ID	Component	Description
A	Projector Information	Provides information about the projector such as the projector name, serial number, software version, and projector ID.
B	Projector and Component Controls	Indicates the states of the projector and its components.
C	Power and Temperature	Indicates the light source mode, power mode, and intake temperature.
D	Status	Contains information about the health of the projector including the number of warnings and errors. Provides access to the status system.
E	IP Settings	Displays the IP address and subnet values. Provides access to changing the IP settings.
F	Test Pattern	Displays the currently selected test pattern. If no test pattern is selected, Off is displayed. Provides access to the list of test patterns.
G	Input	Displays the signal for the currently selected input. Provides access to the list of input signals.

IR/wired remote keypad

The IR/wired remote keypad controls the projector by way of either wireless communications from a battery-powered infrared (IR) transmitter or a wired interface.

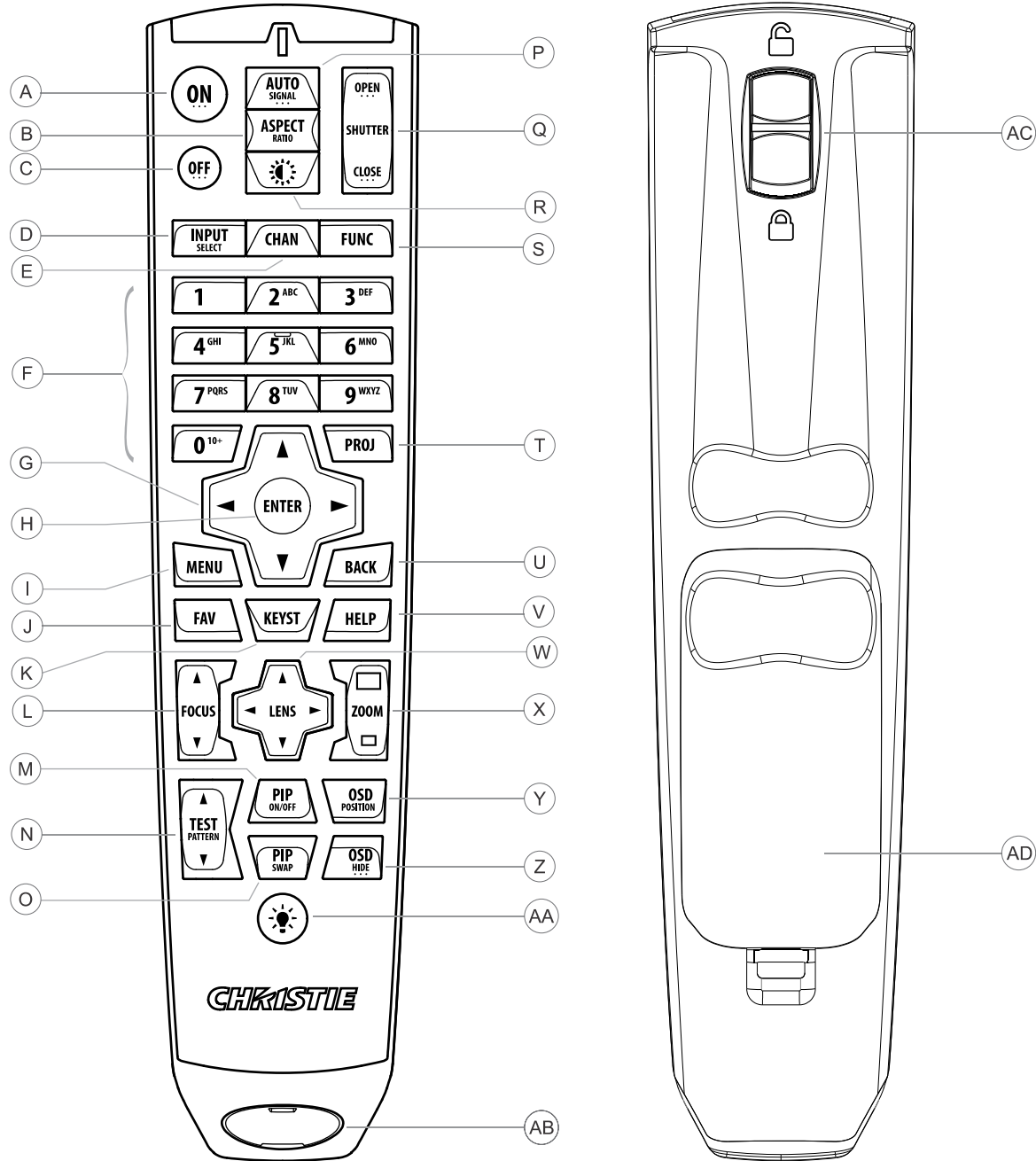

Button	Description
A	Powers on the projector light source.
B	Opens the aspect ratio dialog.

Button	Description
C	Turns off the light source and puts the projector in standby.
D	Selects an active or inactive input on any slot.
E	Not supported.
F	Enter a number, such as menu, item index or value.
G	Use the arrows to navigate within a menu or to adjust settings.
H	Selects a highlighted menu item and changes or accepts a value.
I	Toggles the menus on/off.
J	Not supported.
K	Opens the keystone dialog.
L	Adjusts the lens focus.
M	Not supported.
N	Displays a test pattern.
O	Not supported.
P	Optimizes the image automatically.
Q	Opens or closes the shutter.
R	Not supported.
S	Initiates a custom action when a number is selected.
T	Selects a projector in multi-projector installations.
U	Returns to the previous menu level or exits menus if at the top level.
V	Displays context-sensitive help.
W	Arrows adjust the lens offset.
X	Adjust the lens zoom.
Y	Opens the on-screen display position menu.
Z	Shows or hides the on-screen display menus.
AA	Turns the remote backlight on.
AB	Male 3-pin XLR connector for wired option.
AC	Lock/unlock the keypad.
AD	Battery door.

Required tools

Make sure the following tools are available during the installation.

- 12 in. screwdrivers: Phillips #2 (magnetic) and flat
- 2.5mm, 3mm, and 5mm hex drivers

- Adjustable wrench
- Step stool
- Powder-free N-DEX gloves
- Clean dry air (CDA)
- Isopropyl alcohol
- Cotton swabs

Preparing the installation site

Ensure the installation area is ready for the components.

1. Clear the installation area.
2. Post laser hazard warning signs at all entry doors.
3. Place each component near its installation location.

Lifting and positioning the projector

Safely lift and position the projector in the location where it will be used.



Warning! If not avoided, the following could result in death or serious injury.

- A minimum of four people or appropriately rated lift equipment is required to safely lift, install, or move the product.
 - Do not install or operate the projector in any position that does not meet the stated product specifications for alignment and orientation.
1. Position each person at the corners of the projector.
 2. Lift up the projector and move it to the location where it will be used.
 3. Position the projector so it is centered and parallel with the theater screen.

If space is limited, aim the projector slightly off-center and use lens offset to center the image on the screen.

Related information

Light intensity hazard distance (on page 8)

Leveling the projector

Use the projector feet to level the projector.

1. To adjust the vertical position of the projector, extend or retract the adjustable feet on the bottom of the projector using the adjustable knobs on the feet.

Christie recommends adjusting the feet from the side or rear of the projector and not the front to avoid exposure to the output light.

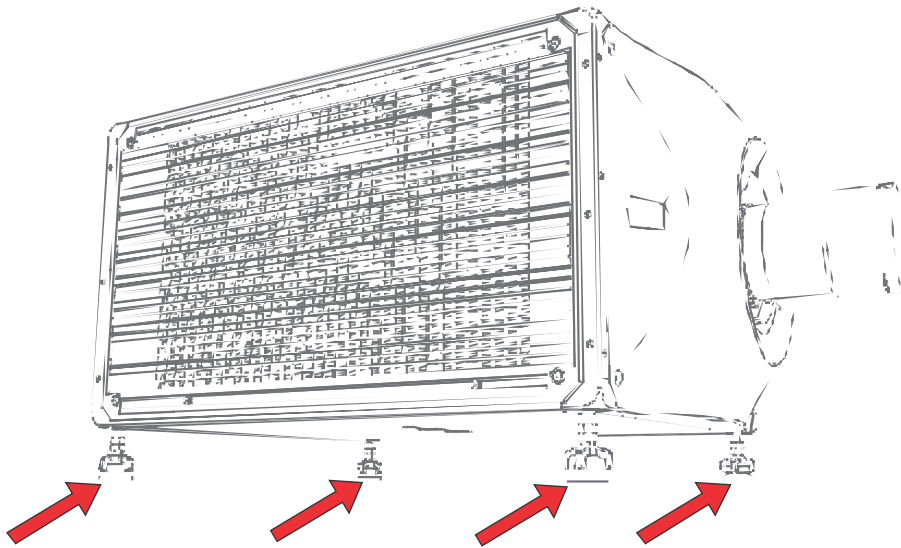

The projector feet are removable and can be moved to the top of the projector to run in an inverted orientation.

2. Once the required adjustment is made, using a wrench, tighten the lock nut against the bottom of the projector.

Installing the projector lens

Only use lenses designed for Mirage 4K40-RGB projectors. Installing a lens not designed for Mirage 4K40-RGB, results in a warning that the lens is not present.

1. Turn off the lasers.
2. Remove the lens caps from the lens.
The packaging tape is required to ensure safe shipment of the projection lens to restrain the zoom ring from rotating during shipping.
3. Align the guides on the front cover and the lens marked by a red line.

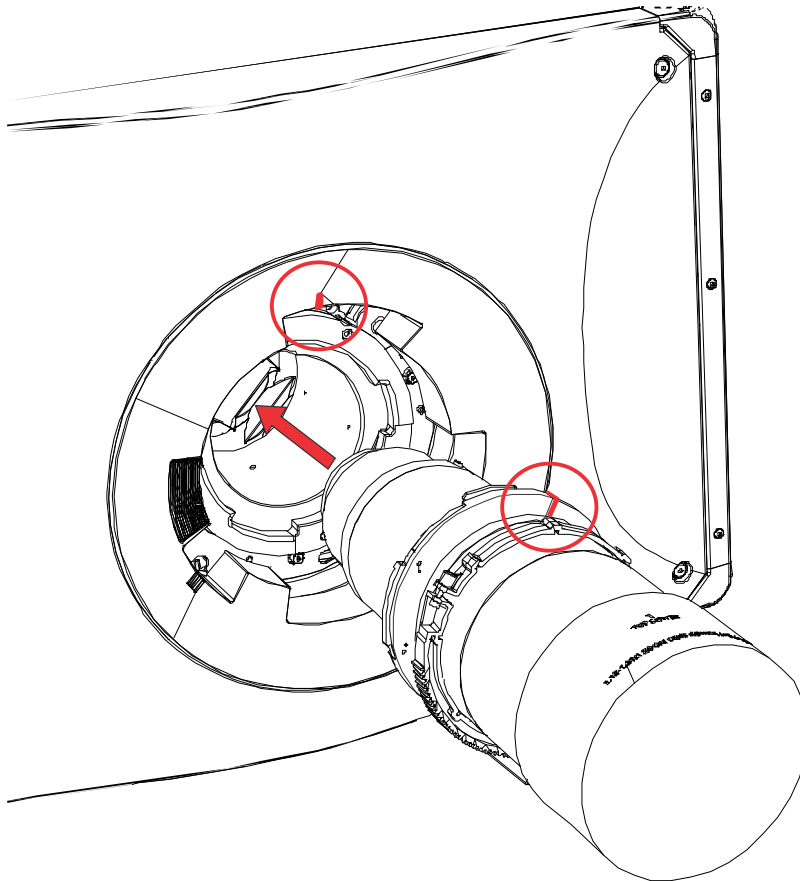

4. Insert the lens into the projector and turn it clockwise until you hear two clicks. The first click indicates the safety lock mechanism has been engaged.
5. Continue to turn the lens clockwise until you hear a second click. The second click indicates the lens is fully locked in position. The top center label should face up and be aligned to the lens guide on the front cover.

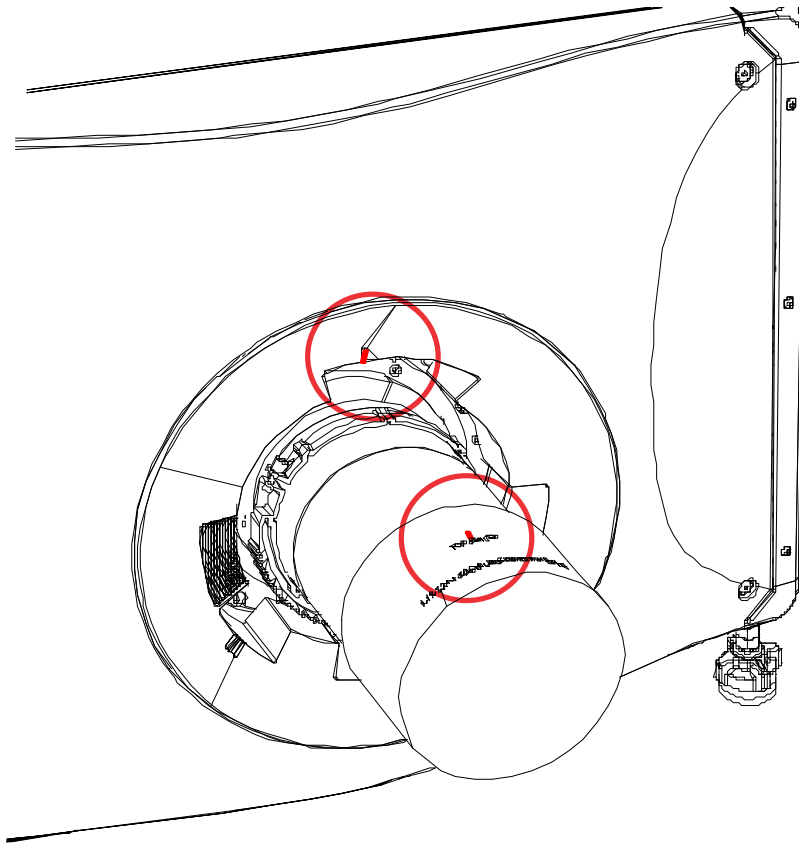

Calibrating the lens motor

Ensure the lens motor is calibrated before using the projector.

If the lens motors are not calibrated properly, implications may include:

- Incorrect reporting of the lens motor position.
- Inability to use the full range of the lens motors.
- Lens motors traveling outside of the pre-defined keep-out area.
- Damage to the projector.

Calibrate the lens motors when any of the following conditions are met:

- After a lens change.
- After the projector is moved and/or jostled.
- After any manual adjustment is made to the zoom or focus.

To calibrate the lens:

1. Select **MENU** > **Configuration** > **Lens Settings** > **Lens Calibration**.
2. Select **Enter**.

Removing the projection lens

Use the correct method of removing the lens.

1. Turn off the lasers.
2. Push in and hold the lens release button.

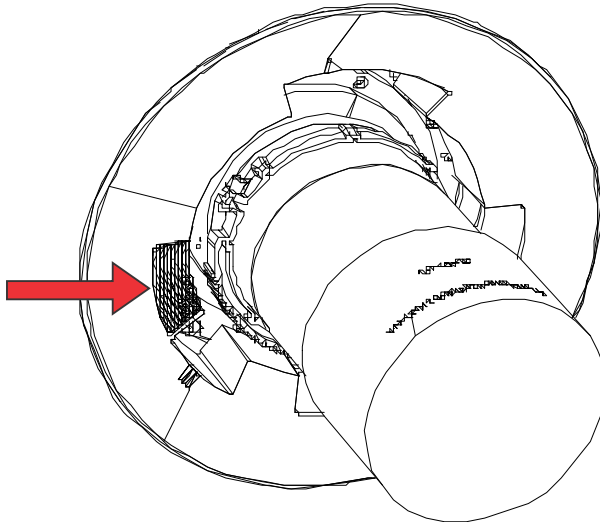

3. Turn the lens counterclockwise until the lens guides are aligned.
4. Slide the lens straight out of the projector.
If the lens does not slide out easily, reset the lens offset before removing the lens.
5. Attach the lens cap to avoid damage.



Warning! If not avoided, the following could result in death or serious injury.

- Once the lens removal has begun the safety retention features of the lens are defeated. To re-engage the safety lock mechanism, the lens must be removed and re-inserted, or fully rotated clockwise until a click is heard.
- Packaging tape is required to ensure safe shipment of the projection lens to restrain the zoom ring from rotating during shipping.

Installing the ultra short throw projector lens

Learn how to install the ultra short throw projection lens.



The illustrations in this document are for representation only and may not depict your projector model exactly.

1. Switch to the ultra short throw lens keep-out area.
 - a) Select **MENU > Configuration > Lens Settings**.
 - b) Select **Enable UST Lens (0.38:1)**.
 - c) To enable the ultra short throw lens keep-out area, select **Enter**.

Not switching to this keep-out area risks damaging the projector when the ultra short throw lens is installed.

2. Turn off the lasers.

3. Remove the lens caps from the lens.
4. Align both the guide on the front cover and the lens marked by a red line, and the insert plates on the lens.
5. Insert the lens into the projector and turn it clockwise until it is locked in place.
Make sure the lens is supported near the front element.

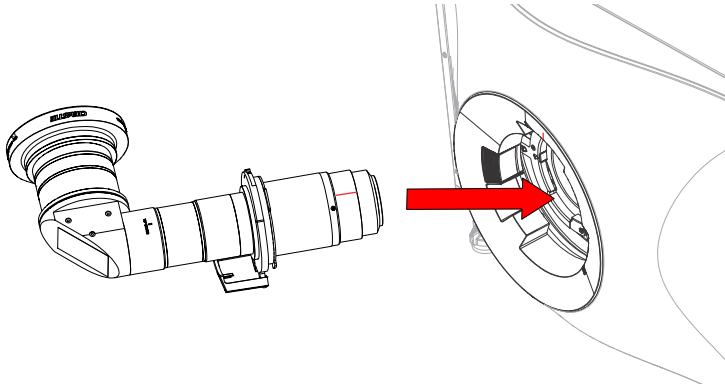

Aligning and focusing the image (ultra short throw lens)

After installing the lens, align and focus the image.

The method for performing the steps below may vary depending on projector model. For detailed information, refer to the user documentation for your product.

1. If required, power on the projector.
2. Perform a lens calibration.
3. To align the image, position the projector and adjust offsets.
4. Adjust boresight.
5. Adjust the center focus of the image by using the Focus feature on the projector.
6. Manually adjust the corner focus of the image using the focus ring on the lens.

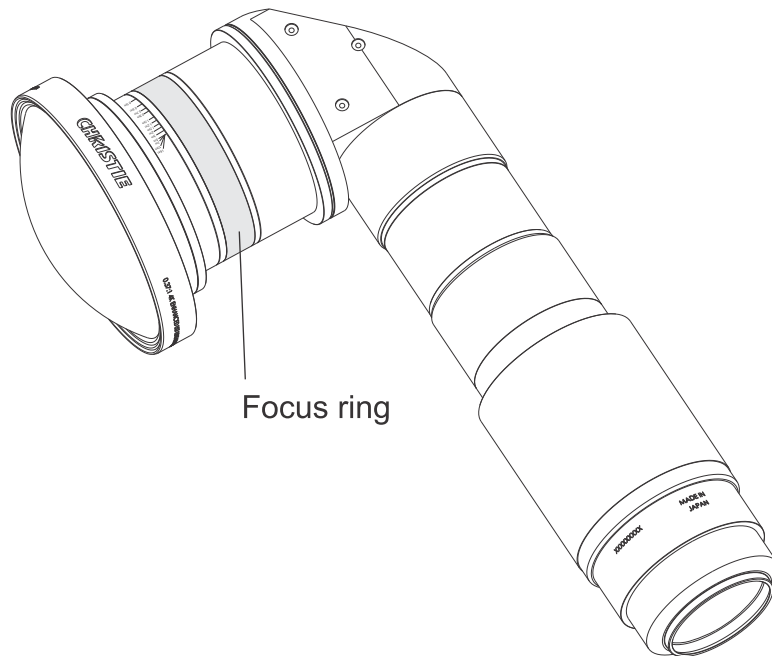

7. To fine tune the focus, repeat steps 5 and 6 until optimum focus is achieved.

Connecting to AC power

Connect AC power to the projector.

1. Plug the AC power cord into the projector.
2. Secure the AC power cord with the power cord retainer.

Turning on the projector

When the projector AC power supply is plugged in and the breaker switch is on, the power is on.



Warning! If not avoided, the following could result in death or serious injury.

- **SHOCK HAZARD!** Do not attempt operation if the AC supply is not within the specified voltage and current, as specified on the license label.
1. Plug the projector into AC power and turn on the breaker switch.
When plugged in and the breaker switch is on, the projector automatically powers on to standby mode within 60 seconds. The display panel functionality becomes available.
 2. To turn the light source on using the projector keypad, press and hold the **Power**  button until you hear a beep.
To turn on the light source using the remote, press and hold the **ON** button until you hear a beep.

Projector LED status indicators

Identify the LED state colors and meaning.

LED	State		Description
Blue	Solid	Standby	Light source is off. Video electronics are off. Projector status is OK.
	Flashing	Cool down	Projector is moving to one of the two standby states: <ul style="list-style-type: none"> Light source is off and video electronics are booting up. Light source is off. Video electronics and light source is cooling down.
Green	Solid	Light source on	Light source is on. Projector status is OK.
	Flashing	Startup	Projector is moving to light source on state. Light source is warming up. Video electronics are initializing.
Yellow	Solid	Warning in standby	Projector is in standby state. A problem exists with the projector that does not prevent it from operating.
	Flashing yellow/green	Warning during startup	Projector is in a startup state. A problem exists with the projector that does not prevent it from operating.
	Flashing	Warning with light source on	Light source is on. A problem exists with the projector that will not cause it to shut down.
	Flashing yellow/blue	Warning during cool down	Projector is in a cool down state. Light source is off. Video electronics and light source are cooling down. A problem exists with the projector that does not prevent it from operating.
Red	Solid	Error in standby	Projector is in standby. An error exists that prevents the projector from starting up.
	Flashing	Error	An error with the projector exists during startup, cool down, or when the light source is off. Projector will proceed to shut down.
Off		AC off	The AC power is off.

Projector LED shutter indicators

Identify the shutter LED state colors and meaning.

LED	State	Description
Solid magenta	Shutter closed	The shutter is closed. In standby, the shutter is always automatically closed and the magenta light is muted.
Off	Shutter open	The shutter is open.

Turning off the projector

When powering off in preparation for inspection or maintenance, always disconnect from AC.

1. To turn the light source off using the projector keypad, press and hold the  button until you hear a beep.
To turn off the light source using the remote, press and hold the **OFF** button until you hear a beep.
When powering off the projector, allow the projector to complete its cool down cycle. Do not immediately unplug the projector if this can be avoided.
2. To turn off power to the projector, disconnect from AC power.
3. To turn off power to the projector, turn off the projector breaker switch and disconnect from AC power.

Aligning the image

Only perform image alignment after the projector is fully assembled and powered up in its final location.

Basic image alignment ensures the image reflected from the DMDs is parallel and well-centered with the lens and screen. This initial optical alignment is the foundation for optimizing images on the screen and must be completed before final boresight adjustments. Before beginning, make sure the projector is properly positioned in relation to the screen.

1. Make sure the projector is positioned in the throw distance range for the particular lens.
2. Display a test pattern.
3. Do a quick preliminary focus and (if available) zoom adjustment with the primary lens.
Do not worry about consistency across the image at this point, just center focus. It is good practice to have zoom adjustment and focus adjustment in the center of its range.
4. Holding a piece of paper at the lens surface, adjust offsets as necessary until the image is centered within the lens perimeter. A full black field works best for this.
5. If the projector is mounted off center to the screen axis, offset the lens as much as required. Aim the projector over slightly towards the center of the screen, but use caution when doing so, as too much tilt causes excessive keystone distortion.
6. With a framing pattern on screen, double-check projector leveling so the top edge of the image is parallel to the top edge of the screen.

Adjusting offset

Adjust the offset to align the image on the screen. Always adjust offset before adjusting boresight.



For the best optical performance and minimal keystone, use offsets instead of aiming at the center of the image, in off-axis installations. Avoid extreme tilts or offsets. Corner vignettes on a white test pattern indicate extreme offset that should be avoided using mechanical alignment.

1. Project an image with the primary lens.
2. Select a framing test pattern.
3. Select **LENS OFFSET**.
You can also select **MENU > Configuration > Lens Settings > Lens Offset**.

4. Use the arrows to adjust the offset to display a square image on the screen, with minimal projector aiming error.
5. To exit to the home page, select **Back**.

Resetting the lens to home position

Realign the lens to the home position after the lens has been offset and out of alignment.

1. Select **LENS OFFSET**.
You can also select **MENU > Configuration > Lens Settings > Lens Offset**.
2. To reset the lens to the default home position, select **Enter**.
3. To confirm the reset, select **OK**.

Selecting a test pattern

Many test patterns are available to assist with the configuration of the projector and to diagnose any issues that may occur.

1. From the display panel, use the arrows to select **Test Pattern**.
You can also select the test patterns from **MENU > Test Pattern** or pressing **N** on the IR remote.
2. Scroll through the list of test patterns.
3. Select the required test pattern.
4. To confirm your selection, select **Enter**.

Adjusting boresight

The boresight adjustment balances the tilt of the lens mount to compensate for screen-to-projector tilt.



Caution! If not avoided, the following could result in minor or moderate injury.

- Do not look directly into the lens when the light source is on. The extremely high brightness can cause permanent eye damage.
1. Close the shutter on the projector.
 2. Unlock the three lens mount stabilization screws.

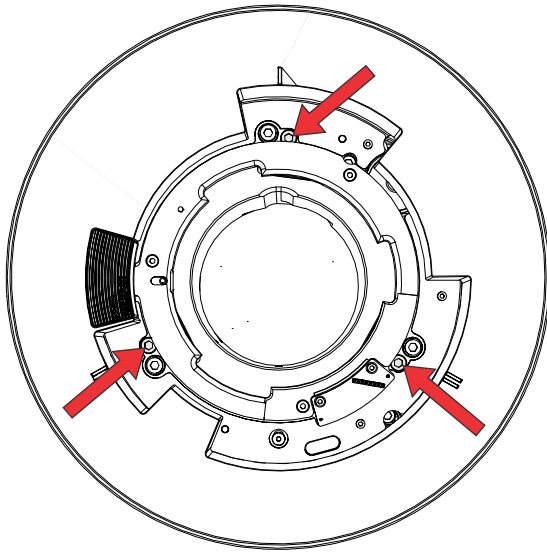

3. Open the shutter.
4. From the Test Pattern menu, select the **Boresight** test pattern.
The Boresight test pattern assists with adjusting the boresight for the three focus points.

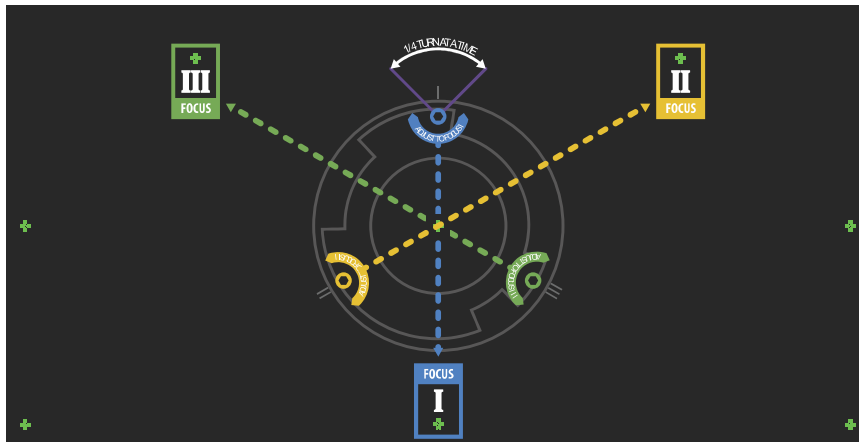

5. To focus the bottom boresight guide, adjust the blue boresight screw.
Adjust the screw 1/4 turn. If you get to the end, further unlock the corresponding stabilization screw.

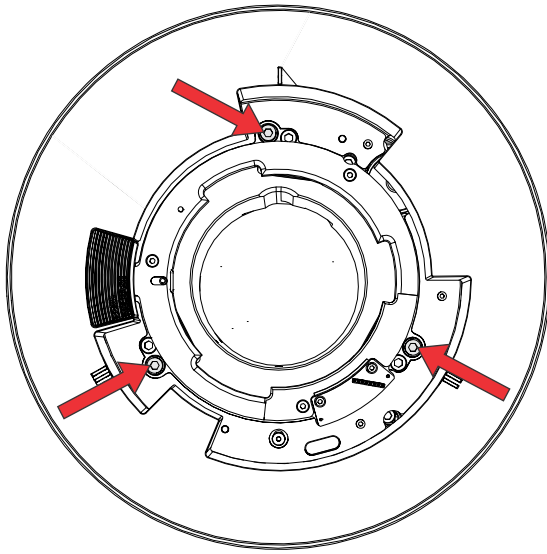

6. To focus the right boresight guide, adjust the green boresight screw.
7. To focus the left boresight guide, adjust the yellow boresight screw.
8. To continue to refine the focus, repeat steps 5 to 7.
9. Before adjusting the stabilization screws, close the shutter.
10. To maintain the adjustments, lock the stabilization screws.
When locking the screws, start with the top stabilization screw and turn it so it just touches the base. Repeat for the other two stabilization screws. Continue to adjust the locking screws until they are tight.
11. Open the shutter.

Optimizing the integrator zoom and focus

Learn how to optimize the integrator zoom and focus.

1. From the Test Pattern menu, select the **Integrator Rod** test pattern.

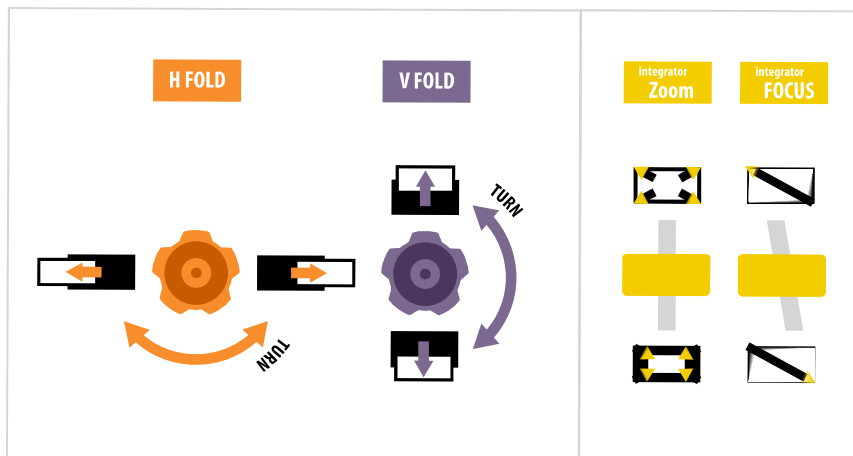

2. Open the Service door on the side of the projector.

3. Unlock the Zoom and Focus paddles.

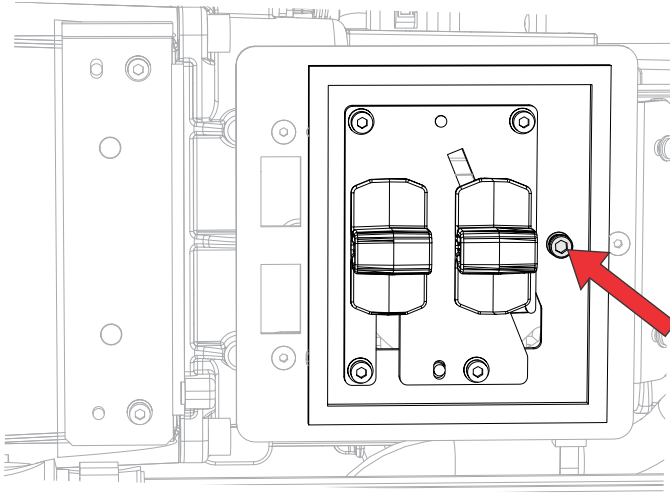

4. Adjust the magnification using the Zoom paddle.
Make sure you do not see any corners.

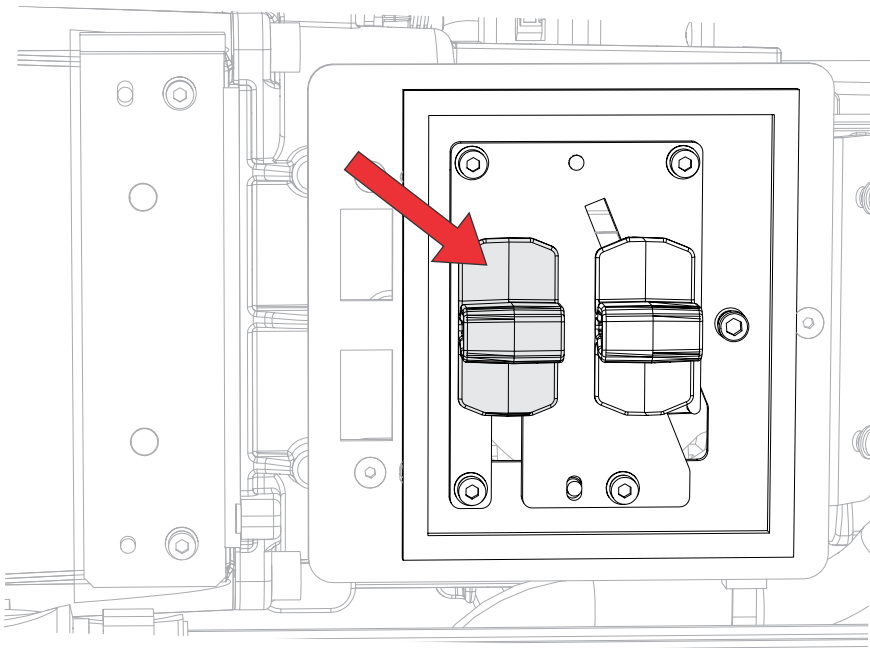

5. Adjust the focus using the Focus paddle.
Always focus the center of the image first and then make sure no blurry edges exist.

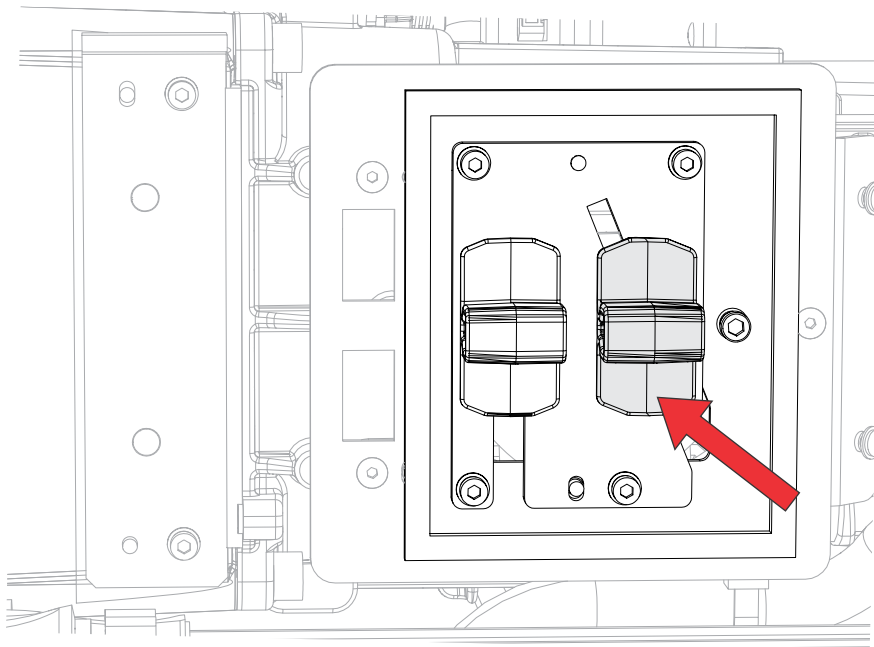

6. To continue to refine the zoom and focus, repeat steps 4 and 5.
7. When complete, lock the Zoom and Focus paddles.

Adjusting the fold mirror

Fold mirror adjustment must be completed by trained personnel.



Notice. If not avoided, the following could result in property damage.

- Misalignment of the fold mirror may cause permanent damage to the product.

1. Set the projector to minimum power.
2. From the Test Pattern menu, select the **Integrator Rod** test pattern.

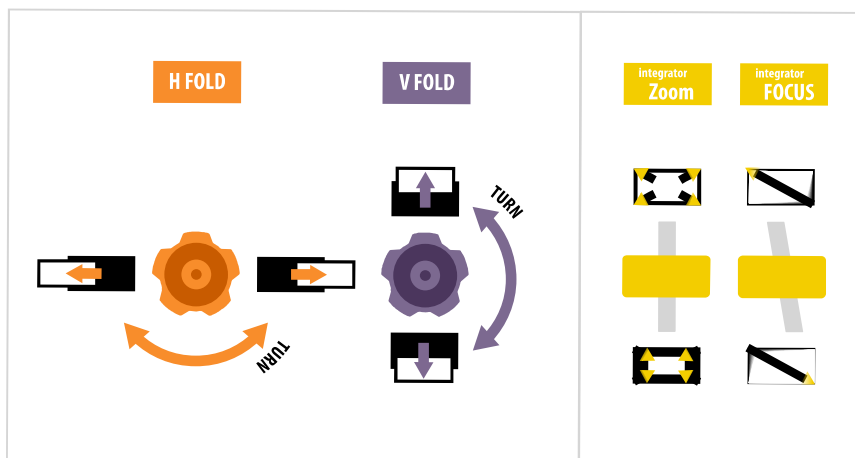

3. Open the Service door on the side of the projector.
4. Unlock the fold mirror screws to unlock the adjustment knobs.

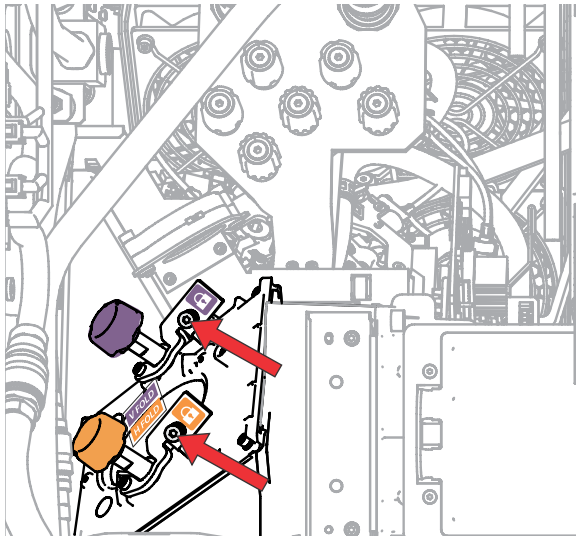

5. To make horizontal adjustments, use the orange knob labeled Horizontal.
6. To make vertical adjustments, use the purple knob labeled Vertical.

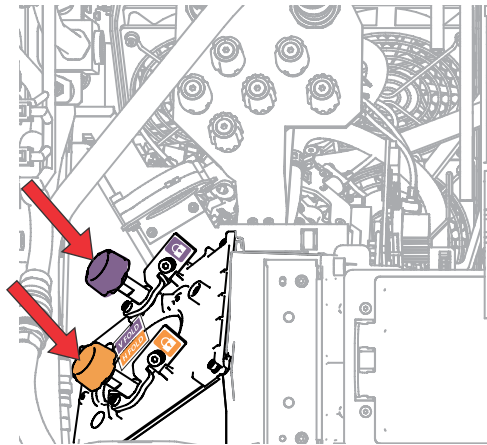

7. To continue to refine the fold mirror adjustment, repeat the horizontal and vertical adjustments.
8. Lock the fold mirror screw to lock the adjustment knobs.
9. Once satisfied with the alignment, increase the projector power.

Mechanically adjusting DMD convergence

A convergence problem can be identified when one or more projected colors (red, green, and blue) appears misaligned when examined with a convergence test pattern.

The three colors should overlap to form pure white lines throughout the image and one or more poorly converged individual colors may appear adjacent to some or all of the lines.

When adjusting the convergence, you are adjusting red and green to blue.



If you wear glasses with corrective lenses when performing this adjustment, make sure you are viewing the test pattern on a straight angle through the optical axis of your glasses and not from a tilted or angled perspective. This avoids a prismatic effect that can appear to shift convergence when viewing at an angle.

1. Before adjusting DMD convergence, make sure the projector has reached a steady operational state.
If switching from a white or bright test pattern to a dark convergence test pattern or if warming up the projector after a shutdown, allow 15 minutes for stabilization so the optics can reach a steady state.
2. Make sure the electronic convergence (ECC) is defaulted before doing mechanical convergence.
3. From the Test Pattern menu, select the **RGB-4K-Convergence** test pattern and display it full screen.

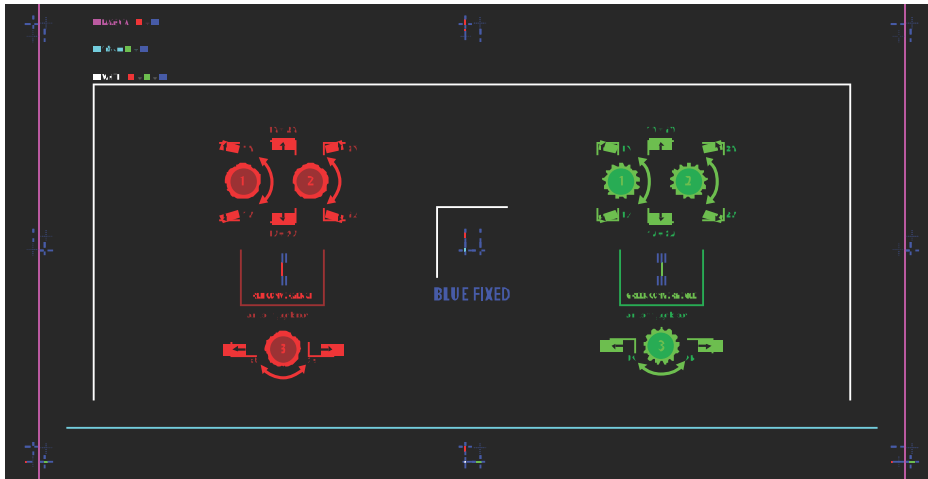

4. Open the Service door on the side of the projector.
5. To adjust the convergence knobs, use the 3 mm driver included with the projector.
If adjusting by hand without using the tool, pull out the convergence adjustment knobs to engage them.

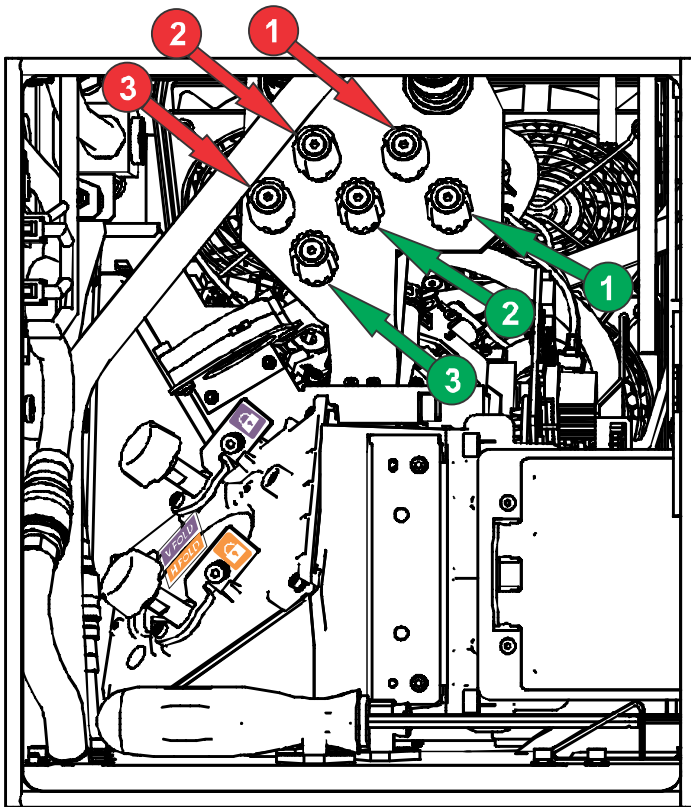

6. Use the Convergence test pattern to assist with adjusting the horizontal and vertical lines. Horizontal adjustments are controlled by adjusting knob 3. Vertical convergence and rotation are controlled by adjusting knobs 1 and 2. Christie recommends rotating a single knob a maximum of a quarter rotation before adjusting the second knob a quarter rotation. For example, if using one hand, turn the left knob a quarter rotation and then the right knob a quarter rotation, and so on. Adjusting a single knob for vertical or rotational adjustment to an extreme before adjusting the second knob may result in the convergence mechanism binding.



For the best stability, Christie recommends setting convergence while rotating the knobs in a clockwise direction. This may require first adjusting convergence by turning the knobs counter-clockwise and finalizing the convergence with a clockwise approach. This applies to all knobs.

7. When complete, push in all the convergence adjustment knobs to disengage them.

Aligning the image with lens zoom and focus

The lens zoom and focus adjustment allows the projected image to be focused and shifted to align with the screen.

1. Display an image or test pattern that can be used to analyze image focus and geometry.
2. Select **ZOOM**.
3. Use the up and down arrows to zoom in or out of the image.
4. To exit, select **Back**.
5. Select **FOCUS**.

6. Use the up and down arrows to adjust the focus of the image.
7. To exit, select **Back**.
8. To refine your adjusts, repeat steps 2 to 7.

Running Auto Setup to optimize display settings

Auto Setup initiates an automated process in which the projector optimizes video settings for the active signal. Auto Setup helps to save time in perfecting a display and you can modify the adjustments as required.

1. Make sure of the following before running Auto Setup:
 - *Test patterns are turned off* (on page 31).
 - The active signal is valid.
2. From the remote, select **Auto Signal** or from the web UI, select **Auto Setup**.
3. Select **Run Auto Setup**.
The system optimizes the active signal and displays a progress message on screen.

Configuring Mirage 4K40-RGB to work with Christie Link

Configure Mirage 4K40-RGB to work with Christie Link, which provides a fully integrated fiber solution for long range video transport.

1. Turn on Mirage 4K40-RGB.
2. Verify the HBMIC has been installed in slot 0.
3. To enable the Christie Link option, select **MENU > Configuration > Input Settings > Enable Christie Link (Slot 0)**.
This option is disabled if an HBMIC is not installed.
4. Select **Enter**.
5. Select the QSFP+ option as the input setting.
 - a) From the side panel home page, select **Input**.
 - b) On the Input selection page, select the appropriate input marked **Christie Link**.
More than one input source may be listed as **Christie Link**, depending on how many signals are being sent from Christie Link.

Related information

Turning on the projector (on page 28)

Completing the installation checklist

Complete the provided installation checklist (P/N: 020-103137-XX) and return it to Christie.

Connecting devices and establishing communication

Learn how to connect external devices to the projector.

Communication and input ports are located on the projector side input panel (operator side). The image below shows an example of the video option card slot numbers and the IMXB panel; your panel may look different.

Video sources can be connected to either the ports on the video option cards or the HDBaseT port on the IMXB.

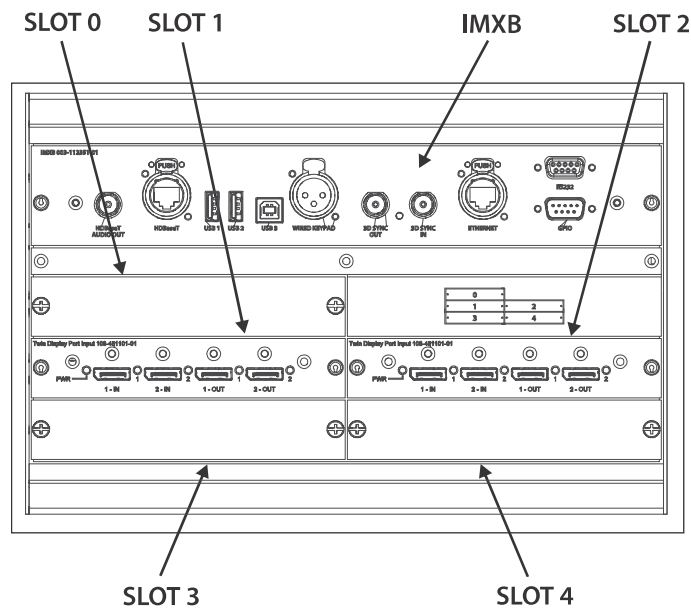

IMXB ports

The IMXB has a variety of ports that can be used for control, 3D sync, upgrading, retrieving interrogators, and connecting audio.

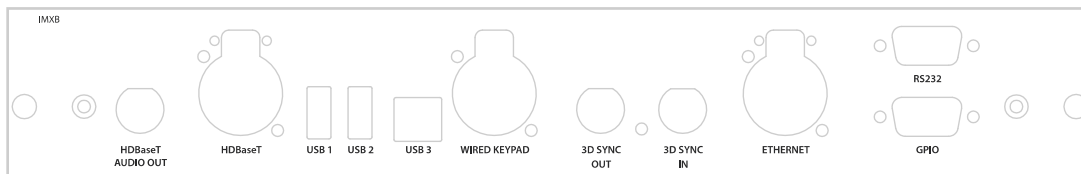

Port	Description
Audio Out	Not supported.
HDBaseT	Accepts video signals, Ethernet, and IR.
USB 1/USB 2	Connects a USB flash drive that has been formatted with a FAT32 file system. Can be used for upgrades, backups, restores, and interrogators.
USB 3	For manufacturing use only.
Wired Keypad	Physically connects a remote control to the projector.
3D Sync In/3D Sync Out	Supported for 3D-enabled projectors.
Ethernet	Connects to the web user interface and can send Christie serial commands.
RS232	Sends Christie serial commands using a standard RS232 serial cable.
GPIO	Provides a method for controlling the projector using electrical signals.

Connecting a video source using 3G input card

The 3G input card (3GIC) accepts digital video data from HD and 3G-SDI (Serial Digital Interface) sources.

Part number: 108-313101-02+

The input configurations listed below are supported.

Input configuration	Description	Requirements
Four-Port	Enables connection of four SDI cables to two 3GIC cards. Each SDI input supplies one quadrant or column of a 4K input image. This configuration supports high resolution and high frame rate input video streams.	Two 3GIC cards
Four-Port, Dual-Input 3D	May be used for Dual-Input 3D configurations.	Four 3GIC cards
One-Port	Enables connection of one SDI cable to the 1-IN input of a 3GIC card (in any slot). In this configuration the SDI input supplies the entire video raster.	One 3GIC card
One-Port, Dual-Input 3D	May be used for Dual-Input 3D configurations.	One 3GIC card

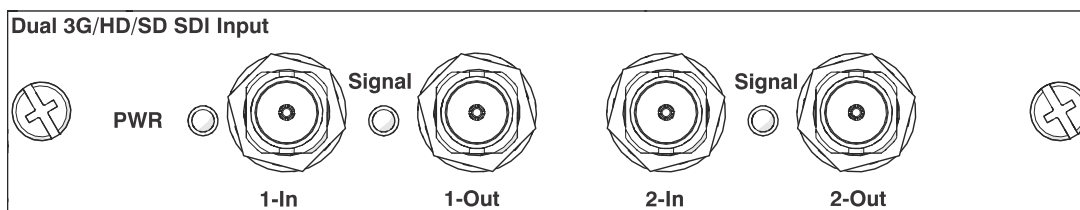

This card may or may not be included with your model. Standard inputs are subject to change. Refer to the *Mirage 4K40-RGB Specifications Guide (P/N: 020-103016-XX)* for more details.

Related information

3GIC video formats (on page 56)

Dual-input 3D (on page 57)

Connecting a video source using DVI

The Dual Link DVI input card (DDIC) accepts digital video source from DVI sources. It does not support incoming analog signals.

Part number: 108-312101-XX

The input configurations listed below are supported.

Input configuration	Description	Requirements
Four-Port	Enables connection of four DVI cables to four DDIC cards. Each DVI input supplies one quadrant or column of a 4K input image. This configuration supports high resolution and high frame rate input video streams.	Four DDIC cards
Two Port	Enables connection of two DVI cables to two DDIC cards. Each DVI input supplies one of two columns of a 4K image.	Two DDIC cards
Two-Port Dual-Input 3D	May be used for Dual-Input 3D configurations.	Four DDIC cards
One-Port	Enables connection of one DVI cable to the DVI input of a DDIC card (in any slot). In this configuration, the DVI input supplies the entire video raster.	One DDIC card
One-Port, Dual-Input 3D	May be used for Dual-Input 3D configurations.	Two DDIC cards

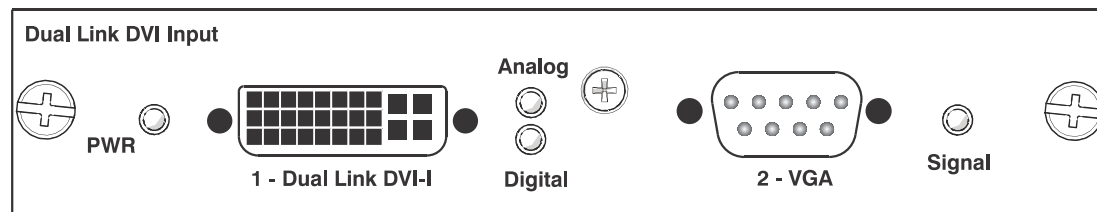

This card may or may not be included with your model. Standard inputs are subject to change. Refer to the *Mirage 4K40-RGB Specifications Guide (P/N: 020-103016-XX)* for more details.

Related information

DDIC video formats (on page 55)

Dual-input 3D (on page 57)

Connecting a video source using DisplayPort

The Twin DisplayPort input card (TDPIC) or QDPIC card accepts digital video data from the DisplayPort sources.

Part number: 108-451101-XX (TDPIC) and 144-114107-XX (QDPIC)

The input configurations listed below are supported.

Input configuration	Description	Requirements
Four-Port	Enables connection of four DisplayPort cables to two or four TDPIC cards or one QDPIC card. Each DisplayPort input supplies one quadrant or column of a 4K input image. This configuration supports high resolution and high frame rate input video streams.	Two or four TDPIC cards or one QDPIC card
Four-Port Dual-Input 3D	May be used for Dual-Input 3D configurations.	Four TDPIC cards
Two-Port	Enables connection of two DisplayPort cables to two TDPIC cards or one QDPIC card. Each DisplayPort input supplies one of two columns of a 4K input image.	Two TDPIC cards or one QDPIC card
Two-Port Dual Input 3D	May be used for Dual-Input 3D configurations.	Four TDPIC cards
One-Port	Enables connection of one DisplayPort cable to a TDPIC card or one QDPIC card. In this configuration the DisplayPort input supplies the entire video raster.	One TDPIC card or one QDPIC card
One-Port, Dual-Input 3D	May be used for Dual-Input 3D configurations.	One TDPIC card

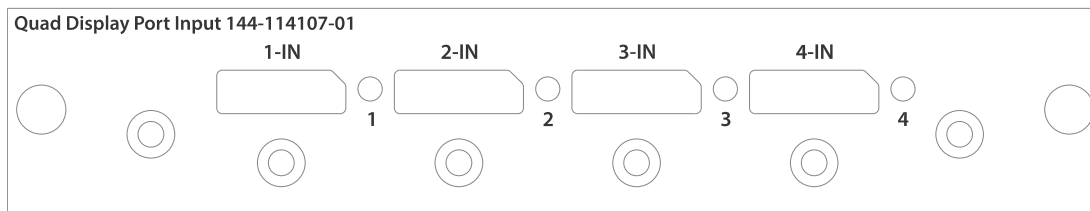
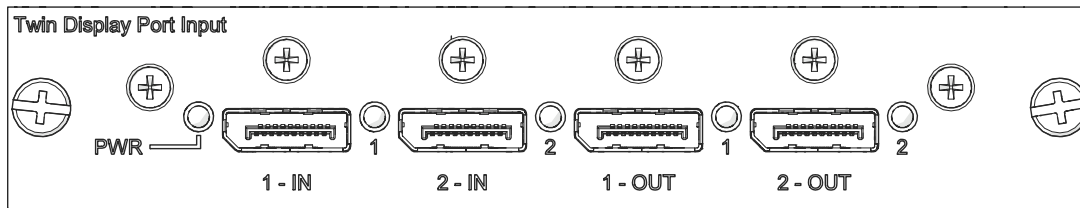

This card may or may not be included with your model. Standard inputs are subject to change. Refer to the *Mirage 4K40-RGB Specifications Guide (P/N: 020-103016-XX)* for more details.

Related information

TDPIC video formats (on page 54)

Dual-input 3D (on page 57)

Connecting a video source using HDMI

The Twin HDMI input card (THIC) accepts digital video data from HDMI sources.

Part number: 108-311101-XX

The input configurations listed below are supported.

Input configuration	Description	Requirements
Four-Port	Enables connection of four HDMI cables to two THIC cards. Each HDMI input supplies one quadrant or column of a 4K	Two THIC cards

Input configuration	Description	Requirements
	input image. This configuration supports high resolution and high frame rate input video streams.	
Four-Port, Dual-Input 3D	May be used for Dual-Input 3D configurations.	Four THIC cards
One-Port	Enables connection of one HDMI cable to the 1-IN input of a THIC card (in any slot). In this configuration, the HDMI input supplies the entire video raster.	One THIC card
One-Port, Dual-Input 3D	May be used for Dual-Input 3D configurations.	One THIC card

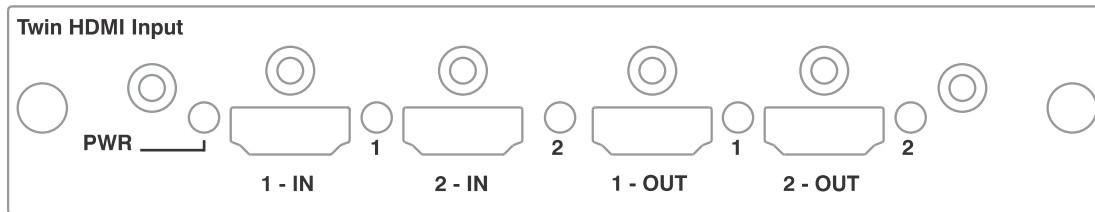

This card may or may not be included with your model. Standard inputs are subject to change. Refer to the *Mirage 4K40-RGB Specifications Guide (P/N: 020-103016-XX)* for more details.

Related information

THIC video formats (on page 56)

Dual-input 3D (on page 57)

Connecting a video source using HBMIC

The high bandwidth multi-input card (HBMIC) accepts digital video data from QSFP+, DisplayPort, HDMI, and 12G, 6G, 3G, and HD SDI sources.

Part number: 144-116109-XX

Input configuration	Description	Requirements
One-Port	Enables connection of any one of the input standards, processes it, and routes it to the backplane interface. The module allows for concurrent processing of HDMI 2.0, DisplayPort 1.2, and SDI inputs to enable preview capability and fast syncing/switching between inputs. It can also be switched to Christie Link mode allowing interfacing with the Christie Link transmitter.	1 HBMIC card
One-Port, Dual-Input 3D	May be used for SDI inputs.	1 HBMIC card

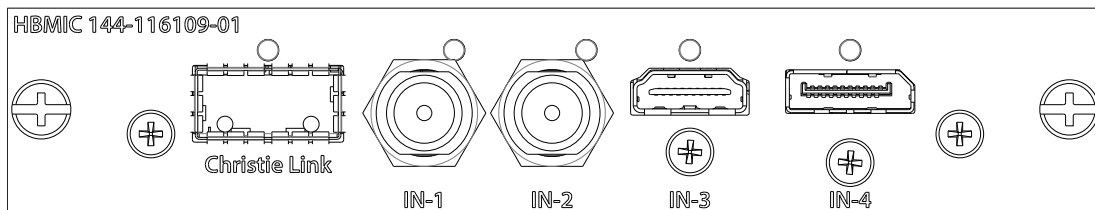

This card may or may not be included with your model. Standard inputs are subject to change.

Related information

HBMIC video formats (on page 52)

Dual-input 3D (on page 57)

Connecting a video source using TSIC

The Terra SDVoE (TSIC) input card accepts digital video data from a Christie Terra Transmitter.

Part number: 144-132107-XX

The input configuration listed below is supported.

Input configuration	Description	Requirements
One-Port	Enables a connection from an SDVOE source (such as the Christie Terra Transmitter) and routes it to the backplane interface. Refer to the signal chart for more information about what resolution, frame rates, and formats are supported based on the projector the card is installed in.	1 TSIC card

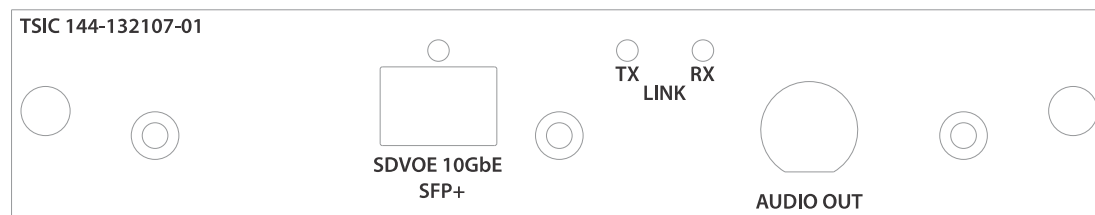

This card may or may not be included with your model. Standard inputs are subject to change. Refer to the *Mirage 4K40-RGB Specifications Guide* (P/N: 020-103016-XX) for more details.

Related information

TSIC video formats (on page 54)

Connecting a video source using HDBaseT

The HDBaseT port on the IMXB accepts digital video data from HDBaseT sources.

The input configurations listed below are supported.

Input configuration	Description	Requirements
One-Port	Enables connection of one Ethernet cable to the HDBaseT port on the IMXB. The HDBaseT input supplies the entire video raster.	N/A

This card may or may not be included with your model. Standard inputs are subject to change. Refer to the *Mirage 4K40-RGB Specifications Guide* (P/N: 020-103016-XX) for more details.

Related information

HDBase-T video formats (on page 57)

Selecting a video source

After connecting a video source to the projector and making sure your port configuration is correct, you must select it.

1. From the display panel, select **INPUT**.
2. Navigate the list of input selections until you find a selection that best matches your configuration.

The range of available input selections depends on the projector model and/or input/output combinations. When the Default configuration is selected, the following inputs are supported for each configuration:

- One-port—HDMI, SDI, DisplayPort, Christie Link, HDBaseT
- Two-port—DisplayPort, Christie Link
- Four-port quadrants—SDI
- One-port dual-input 3D (3D license-specific)—SDI, DisplayPort, Christie Link

When SDVoE is selected, the HDMI, SDVoE, Christie Link, and HDBaseT inputs are supported for the one-port configuration.

3. To select the input, select **Enter**.

Connecting to a computer or server

Communicate with a remote computer, server, or an existing network using a RJ-45 cable.

The RS232 port located on the IMXB faceplate uses the Christie proprietary protocol and is intended for Christie accessories or automation controllers only.

For more information, on the serial commands, see the *Mirage 4K40-RGB Serial Commands Guide* (P/N: 020-103028-XX) .

1. Use an RJ-45 cable to connect the Ethernet hub or switch to the Ethernet port, located on the projector IMXB faceplate.
2. When using the Christie serial protocol over Ethernet, connect to port 3002.
3. For applications or equipment using serial communications, use the Christie proprietary serial protocol to communicate with the RS232 port on the IMXB faceplate.

Configuring the RS232 port

Configure the RS232 port to send Christie serial commands using a standard RS232 serial cable.

For more information, on the serial commands, see the *Mirage 4K40-RGB Serial Commands Guide* (P/N: 020-103028-XX) .

1. Select **Menu > Communications > Projector Communication**.
2. Use the down arrow to select **Baud Rate**.
3. Select the appropriate baud rate and select **Enter**.
4. Use the down arrow to select **Network Routing**.
5. Select the type network routing appropriate for your projector and select **Enter**.

Setting up the Ethernet

Ethernet is set up to obtain an IP address automatically if a DHCP server is on the network, modify IP settings, or manually enter an address.

Christie recommends using the Ethernet port on the IMXB as the HDBaseT port is limited to 100 Mb/s.



You cannot change the IP settings using the web interface.

1. From the display panel, use the arrow keys to select **IP Settings**.
2. To set the type of network, select **DHCP** or **Static**.
3. If you selected Static, manually enter the network information for the **IP Address**, **Subnet**, and **Gateway**.
4. Select **Apply** and select **Enter**.
5. Select **MENU** > **Communications** > **Network Settings**.
6. Select **Device name**.
7. Use the up and down keys to enter the name of the projector.
8. Select **Enter**.

3D setup

The projector is capable of displaying stereoscopic 3D video sources, relying on additional hardware (stereo emitters and glasses) to complete the display system.

Images generated from a stereo 3D video source consist of a series of images (frames) that alternate quickly between two slightly different viewpoints, corresponding to our left and right eyes. When these frames are displayed fast enough and viewed with special glasses synchronized to the left/right (L/R) changes, the resulting image appears with the same depth and perspective sense in the real world.

3D requirements

Stereo 3D applications require a stereo 3D-capable source, special hardware and software setups, and the projector's 3D Settings menu option to control the projector's processing, synchronization, and displaying of the stereoscopic 3D source material.

Hardware requirements

Understand the hardware requirements for stereo 3D applications.

- 3D stereo sync cable for direct-input 3D (and frame doubled)
- A source, usually a computer with a 3D graphics card(s)
- Emitter for controlling active shutter glasses

Software and content requirements

Understand the software and content requirements for stereo 3D applications.

- Any 3D computer software that supports 3D stereo on a supported computer(s) with associated graphic cards (suggested cards include ATI or NVIDIA)
- A video stream from a video source prepared to be sequential content (for direct-input 3D) or two video streams from a video source that has been prepared to be supplied left eye and right eye concurrently and frame locked (dual-input 3D)

Active stereo 3D configuration

Use the following diagram to understand a typical hardware configuration for active stereo 3D systems.

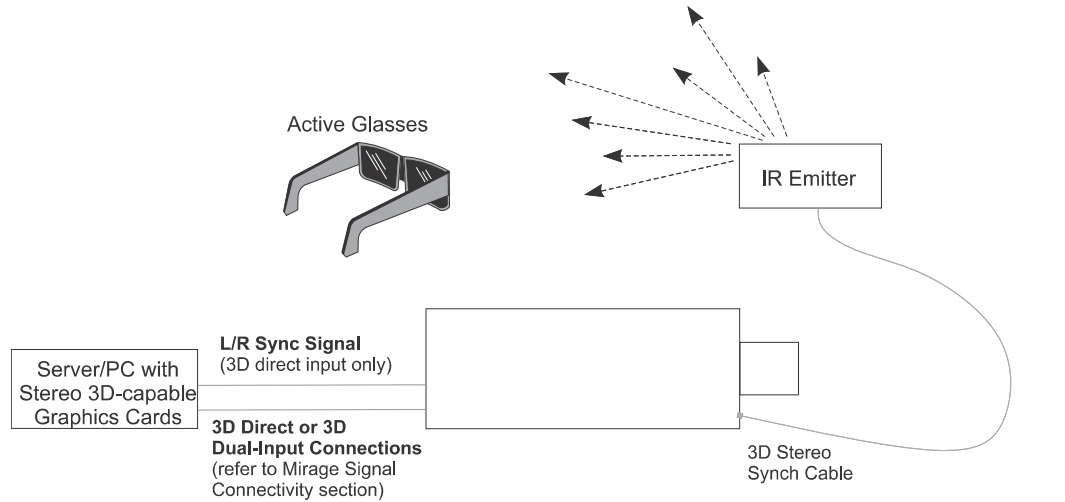

In response to the 3D Sync Out signal from the projector, the IR emitter emits an infrared signal to a receiver in the active 3D shutter glasses. This synchronizes the active glasses to alternatively open and close for the active stereo 3D applications.

Passive stereo 3D configuration

Use the following diagram to understand a typical hardware configuration for passive stereo 3D systems.

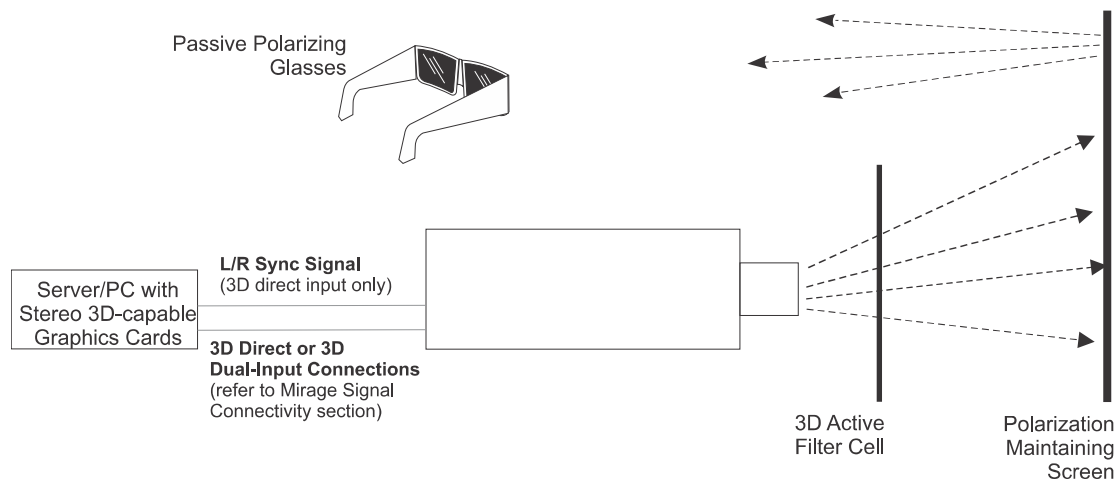

3D system timing

The projected video must be optimized for the glasses’ shutter speed or polarization filter performance to prevent obvious “ghosting” of the video content (known as cross-talk in stereo 3D applications) or other more subtle color artifacts.

Visual performance can be optimized by adjusting the Dark Interval and the 3D Sync Delay settings. Consult the documentation for your glasses or polarization filter and keep their specifications in mind when configuring the projector for 3D operation.

3D input video configurations

The stereo 3D input video stream may be supplied from the video server to the projector in two configurations: direct-input 3D or dual-input 3D.

Configuration	Description
Direct-input 3D	<p>In this configuration a single video stream is provided by the video server, with the left eye and right eye frames supplied as alternate frames within the video stream. A 3D input sync may be used to identify the left eye frames.</p> <p>The direct-input 3D video stream may be supplied by either a Four-Port input video configuration (such as four cables each supplying one quadrant of the image) or an One-Port input video configuration (such as one cable supplying the entire frame).</p>
Dual-input 3D	<p>In this configuration two video streams are provided by the video server, with the left eye supplied by one stream and the right eye supplied by the other. The video streams are frame locked and supplied concurrently.</p> <p>The dual-input 3D video streams may be supplied by either two Four-Port input video configurations (such as four cables each supplying one quadrant of the image for each eye, with a total of eight cables) or two One-Port input video configurations (such as one cable supplying the entire frame for each eye, with a total of two cables).</p>

Setting up a single projector to display 3D content

1. *Enable 3D mode* (on page 50).
2. *Confirm the emitter setup* (on page 51).
3. *Configure the projector for the 3D source* (on page 51).

Enabling 3D mode

Select the mode for your 3D operation.

1. To enable 3D mode, select **MENU > Image Settings > 3D Settings > 3D Mode**.
2. Select the appropriate 3D mode:
 - Off—Disable the 3D operation.
 - Auto Detect—Automatically determine which 3D mode to use based on auxiliary video data, for example, HDMI info frame.

- Multi-Flash 3D—Display content multiple times to provide a 3D image.

Confirming the emitter setup

Define whether the 3D Sync is output and control how it is processed.

1. To set the 3D output to emitter, select **MENU > Image Settings > 3D Settings > 3D Sync Output**.
2. Select **To Emitter**.
3. Select **Enter**.
4. To enable the 3D test pattern, select **3D Test Pattern**.
5. Select **Enter**.
6. To configure the dark interval so the amount of dark time aligns with the amount of time required for the glasses to switch, select **Dark Interval**.
7. Adjust the slider or enter the dark interval value as required.
8. To confirm your selection, select **Enter**.
9. View the displayed test pattern. If you can see both Ls and Rs with both eyes, increase the dark interval until the Ls are only visible to the left eye and the Rs are only visible to the right eye.
10. Optionally, to adjust the 3D Sync delay, select **3D Sync Delay**.
This adjusts the timing of the sync pulse in relation to the dark time transition on the DMDs. Use the default value of 0 as a starting point.
11. Adjust the slider or enter the delay value.
12. To confirm your selection, select **Enter**.

Configuring the projector for the 3D source

Configure the projector for the 3D source.

1. Select the appropriate port configuration and then set the *inputs for your video source* (on page 46).
2. To select the correct EDID timing, select **MENU > Configuration > Input Settings > EDID Timing**.
3. Select the required EDID timing and select **Enter**.
4. Connect all the required cables between the 3D source and the projector.
5. Configure your 3D source.

Connecting devices to the 3D sync ports

The 3D Sync Input and Output ports located on the IMXB faceplate provide a convenient method for interfacing the projector to the 3D stereo projection system.

Connect the 3D Sync Input to the video source for synchronization of the left eye/right eye frames of Direct input 3D or for frame doubled content.

The 3D Sync Input is not required for Dual-Input 3D. The 3D Sync Output is available for control of an IR Emitter for active glasses or a polarization device for passive glasses.

Signal connectivity specifications for Mirage 4K40-RGB

Identify the signal connectivity specifications for Mirage 4K40-RGB.

The list of formats listed below are not exhaustive and other formats may be supported. For more information, contact Christie Technical Support.

For a list of supported Christie Link video formats, see the *Christie Link User Manual (P/N: 020-102234-XX)*.

HBMIC video formats

Identify the video formats for the HBMIC card.

DisplayPort 1.2

This interface supports HDCP 1.x.

	Format	Hres	Vres	Frame rate (Hz)	Sampling	Bit-depth
HD	1280x720	1280	720	24, 25, 30, 50, 60, 120	RGB/4:4:4	8/10/12bpc
	1920x1080	1920	1080	24, 25, 30, 50, 60, 120	RGB/4:4:4	8/10/12bpc
	2048x1080	2048	1080	24, 25, 30, 50, 60, 120	RGB/4:4:4	8/10/12bpc
4K	3840x2160	3840	2160	24, 25, 30, 50, 60	RGB/4:4:4	8/10bpc
	4096x2160	4096	2160	24, 25, 30, 50, 60	RGB/4:4:4	8/10bpc

HDMI 2.0

This interface supports HDCP 1.x and 2.2.

	Format	Hres	Vres	Frame rate (Hz)	Sampling	Bit-depth	Notes
HD	1280x720	1280	720	24, 25, 30, 50, 60, 120	RGB/4:4:4/4:2:2	8/10/12bpc	—
	1920x1080i	1920	1080	50, 60	RGB/4:4:4/4:2:2	8/10/12bpc	—
	1920x1080	1920	1080	24, 25, 30, 50, 60, 120	RGB/4:4:4/4:2:2	8/10/12bpc	—

	Format	Hres	Vres	Frame rate (Hz)	Sampling	Bit-depth	Notes
	2048x1080	2048	1080	24, 25, 30, 50, 60, 120	RGB/4:4:4/4:2:2	8/10/12bpc	—
4K	3840x2160	3840	2160	24, 25, 30	RGB/4:4:4/4:2:2	8/10/12bpc	4:2:2 12-bit only
	3840x2160	3840	2160	50, 60	RGB/4:4:4	8bpc	—
	3840x2160	3840	2160	50, 60	4:2:2/4:2:0	8/10/12bpc	4:2:2 12-bit only
	4096x2160	4096	2160	24, 25, 30	RGB/4:4:4/4:2:2	8/10/12bpc	4:2:2 12-bit only
	4096x2160	4096	2160	50, 60	RGB/4:4:4	8bpc	—
	4096x2160	4096	2160	50, 60	4:2:2/4:2:0	8/10/12bpc	4:2:2 12-bit only
3D	1280x720	1280	720	60	RGB/4:4:4/4:2:2	8/10/12bpc	Frame-packing, top-and-bottom
	1920x1080	1920	1080	24, 25	RGB/4:4:4/4:2:2	8/10/12bpc	Frame-packing

SDI (HD, 3G, 6G, and 12G-SDI)

A valid SMPTE-352 payload is required for this interface.

	Format	Hres	Vres	Frame rate (Hz)	Sampling	Bit-depth	Notes
HD	1280x720	1280	720	24, 25, 30, 50, 60	4:2:2	10bpc	—
	1920x1080i	1920	1080	50, 60	4:2:2	10bpc	—
	1920x1080	1920	1080	24, 25, 30	4:2:2	10bpc	—
	2048x1080	2048	1080	24, 25, 30	4:2:2	10bpc	—
3G	1280x720	1280	720	24, 25, 30, 50, 60	RGB/4:4:4	10/12bpc	Level-A only
	1920x1080i	1920	1080	50, 60	RGB/4:4:4	10/12bpc	Level-A only
	1920x1080	1920	1080	24, 25, 30	RGB/4:4:4	10/12bpc	Level-A only
	1920x1080	1920	1080	50, 60	4:2:2	10bpc	Level-A only
	2048x1080	2048	1080	24, 25, 30	RGB/4:4:4	10/12bpc	Level-A only
	2048x1080	2048	1080	50, 60	4:2:2	10bpc	Level-A only
6G	1920x1080	1920	1080	50, 60	RGB/4:4:4	10/12bpc	—
	2048x1080	2048	1080	50, 60	RGB/4:4:4	10/12bpc	—
	3840x2160	3840	2160	24, 25, 30	4:2:2	10bpc	—
	4096x2160	4096	2160	24, 25, 30	4:2:2	10bpc	—
12G	3840x2160	3840	2160	24, 25, 30	RGB/4:4:4	10/12bpc	—
	3840x2160	3840	2160	50, 60	4:2:2	10bpc	—
	4096x2160	4096	2160	24, 25, 30	RGB/4:4:4	10/12bpc	—
	4096x2160	4096	2160	50, 60	4:2:2	10bpc	—

TSIC video formats

Identify the video formats for the Terra SDVoE (TSIC) input card.

The TSIC (HDMI 2.0) interface supports HDCP 1.x and 2.2.

	Format	Hres	Vres	Frame rate (Hz)	Sampling	Bit-depth	Notes
HD	1280x720	1280	720	24, 25, 30, 50, 60, 120	RGB/4:4:4/4:2:2	8/10/12bpc	—
	1920x1080	1920	1080	50, 60	RGB/4:4:4/4:2:2	8/10/12bpc	—
	1920x1080	1920	1080	24, 25, 30, 50, 60, 120	RGB/4:4:4/4:2:2	8/10/12bpc	—
	2048x1080	2048	1080	24, 25, 30, 50, 60, 120	RGB/4:4:4/4:2:2	8/10/12bpc	—
4K	3840x2160	3840	2160	24, 25, 30	RGB/4:4:4/4:2:2	8/10/12bpc	4:2:2 12-bit only
	3840x2160	3840	2160	50, 60	RGB/4:4:4	8bpc	—
	3840x2160	3840	2160	50, 60	4:2:2/4:2:0	8/10/12bpc	4:2:2 12-bit only
	4096x2160	4096	2160	24, 25, 30	RGB/4:4:4/4:2:2	8/10/12bpc	4:2:2 12-bit only
	4096x2160	4096	2160	50, 60	RGB/4:4:4	8bpc	—
	4096x2160	4096	2160	50, 60	4:2:2/4:2:0	8/10/12bpc	4:2:2 12-bit only
3D	1280x720	1280	720	60	RGB/4:4:4/4:2:2	8/10/12bpc	Frame-packing, top-and-bottom
	1920x1080	1920	1080	24, 25	RGB/4:4:4/4:2:2	8/10/12bpc	Frame-packing

TDPIC video formats

Identify the video formats for the TDPIC card.

The DisplayPort 1.1a interface supports HDCP 1.x.

	Format	Cables	Hres	Vres	Frame rate (Hz)	Sampling	Bit-depth	Notes
HD	1280x720	—	1280	720	24, 25, 30, 50, 60, 120	RGB/4:4:4	8/10bpc	—
	1920x1080	—	1920	1080	24, 25, 30, 50, 60, 120	RGB/4:4:4	8/10bpc	—
	2048x1080	—	2048	1080	24, 25, 30, 50, 60, 120	RGB/4:4:4	8/10bpc	—
4K	3840x2160	—	3840	2160	24, 25, 30	RGB/4:4:4	8/10bpc	—
	4096x2160	—	4096	2160	24, 25, 30	RGB/4:4:4	8/10bpc	—
	3840x2160	2x	1920	2160	50, 60	RGB/4:4:4	8/10bpc	Cannot use both TDPIC inputs at

Format	Cables	Hres	Vres	Frame rate (Hz)	Sampling	Bit-depth	Notes
							once; requires two separate TDPICs
4096x2160	2x	2048	2160	50, 60	RGB/4:4:4	8/10bpc	Cannot use both TDPIC inputs at once; requires two separate TDPICs
3840x2160	4x	1920	1080	50, 60	RGB/4:4:4	8/10bpc	—
4096x2160	4x	2048	1080	50, 60	RGB/4:4:4	8/10bpc	—
3840x2160	4x	1920	1080	120	RGB/4:4:4	8/10bpc	Cannot use both TDPIC inputs at once; requires four separate TDPICs
4096x2160	4x	2048	1080	120	RGB/4:4:4	8/10bpc	Cannot use both TDPIC inputs at once; requires four separate TDPICs

DDIC video formats

Identify the video formats for the DDIC card. The DVI-D interface supports HDCP 1.x.

	Format	Cables	Hres	Vres	Frame rate (Hz)	Sampling	Bit-depth	Notes
HD	1280x720	—	1280	720	60	RGB/4:4:4	8bpc	Dual-link (120 Hz)
	1920x1080	—	1920	1080	24, 25, 30, 50, 60, 120	RGB/4:4:4	8bpc	Dual-link (120 Hz)
	2048x1080	—	2048	1080	24, 25, 30, 50, 60, 120	RGB/4:4:4	8bpc	Dual-link (120 Hz)
4K	3840x2160	—	3840	2160	24, 25, 30	RGB/4:4:4	8bpc	Dual-link
	4096x2160	—	4096	2160	24, 25, 30	RGB/4:4:4	8bpc	Dual-link
	3840x2160	2x	1920	2160	50, 60	RGB/4:4:4	8bpc	Dual-link
	4096x2160	2x	2048	2160	50, 60	RGB/4:4:4	8bpc	Dual-link
	3840x2160	4x	1920	1080	50, 60, 120	RGB/4:4:4	8bpc	Dual-link (120 Hz)
	4096x2160	4x	2048	1080	50, 60, 120	RGB/4:4:4	8bpc	Dual-link (120 Hz)

THIC video formats

Identify the video formats for the THIC card. The HDMI 1.3 interface supports HDMI 1.4a 3D formats and HDCP 1.x.

	Format	Cables	Hres	Vres	Frame rate (Hz)	Sampling	Bit-depth	Notes
HD	1280x720	—	1280	720	24, 25, 30, 50, 60, 120	RGB/4:4:4/4:2:2	8/10/12bpc	—
	1920x1080i	—	1920	1080	50, 60	RGB/4:4:4/4:2:2	8/10/12bpc	—
	1920x1080	—	1920	1080	24, 25, 30, 50, 60	RGB/4:4:4/4:2:2	8/10/12bpc	—
	2048x1080	—	2048	1080	24, 25, 30, 50, 60	RGB/4:4:4/4:2:2	8/10/12bpc	—
4K	3840x2160	4x	1920	1080	24, 25, 30, 50, 60	RGB/4:4:4/4:2:2	8/10/12bpc	—
	4096x2160	4x	2048	1080	24, 25, 30, 50, 60	RGB/4:4:4/4:2:2	8/10/12bpc	—
3D	1280x720	—	1280	720	60	RGB/4:4:4/4:2:2	8/10/12bpc	Frame-packing, top-and-bottom
	1920x1080	—	1920	1080	24, 25	RGB/4:4:4/4:2:2	8/10/12bpc	Frame-packing

3GIC video formats

Identify the video formats for the 3GIC card for HD and 3G-SDI.

	Format	Cables	Hres	Vres	Frame rate (Hz)	Sampling	Bit-depth	Notes
HD	1280x720	—	1280	720	24, 25, 30, 50, 60	4:2:2	10bpc	—
	1920x1080i	—	1920	1080	50, 60	4:2:2	10bpc	—
	1920x1080	—	1920	1080	24, 25, 30	4:2:2	10bpc	—
	2048x1080	—	2048	1080	24, 25, 30	4:2:2	10bpc	—
3G	1280x720	—	1280	720	24, 25, 30, 50, 60	RGB/4:4:4	10/12bpc	Level-A recommended
	1920x1080i	—	1920	1080	50, 60	RGB/4:4:4	10/12bpc	Level-A recommended
	1920x1080	—	1920	1080	24, 25, 30	RGB/4:4:4	10/12bpc	Level-A recommended
	1920x1080	—	1920	1080	50, 60	4:2:2	10bpc	Level-A recommended
	2048x1080	—	2048	1080	24, 25, 30	RGB/4:4:4	10/12bpc	Level-A recommended
	2048x1080	—	2048	1080	50, 60	4:2:2	10bpc	Level-A recommended

	Format	Cables	Hres	Vres	Frame rate (Hz)	Sampling	Bit-depth	Notes
3G-4K	3840x2160	4x	1920	1080	24, 25, 30	RGB/4:4:4	10/12bpc	Level-A recommended
	3840x2160	4x	2048	1080	50, 60	4:2:2	10bpc	Level-A recommended
	4096x2160	4x	1920	1080	24, 25, 30	RGB/4:4:4	10/12bpc	Level-A recommended
	4096x2160	4x	2048	1080	50, 60	4:2:2	10bpc	Level-A recommended

HDBase-T video formats

Identify the video formats for the HDBase-T card. The HDMI 1.4 interface supports HDCP 1.x.

	Format	Hres	Vres	Frame rate (Hz)	Sampling	Bit-depth	Notes
HD	1280x720	1280	720	24, 25, 30, 50, 60, 120	RGB/4:4:4/4:2:2	8/10/12bpc	—
	1920x1080i	1920	1080	50, 60	RGB/4:4:4/4:2:2	8/10/12bpc	—
	1920x1080	1920	1080	24, 25, 30, 50, 60, 120	RGB/4:4:4/4:2:2	8/10/12bpc	—
	2048x1080	2048	1080	24, 25, 30, 50, 60, 120	RGB/4:4:4/4:2:2	8/10/12bpc	—
4K	3840x2160	3840	2160	24, 25, 30	RGB/4:4:4/4:2:2	8bpc	—
	4096x2160	4096	2160	24, 25, 30	RGB/4:4:4/4:2:2	8bpc	—
3D	1280x720	1280	720	60	RGB/4:4:4/4:2:2	8/10/12bpc	Frame-packing, top-and-bottom
	1920x1080	1920	1080	24, 25	RGB/4:4:4/4:2:2	8/10/12bpc	Frame-packing

Dual-input 3D

Identify the video formats for the Dual-input 3D.

One set of cables is required for left-eye and another set is required for right-eye. The output rate depends on the input rate (per eye) as follows:

- 24 Hz signals are triple-flashed resulting in an output rate of 144 Hz.
- 25 Hz signals are triple-flashed resulting in an output rate of 150 Hz.
- 30 Hz signals are double-flashed resulting in an output rate of 120 Hz.
- 60 Hz signals are single-flashed resulting in an output rate of native 120 Hz.

HBMIC

A valid SMPTE-352 payload is required for the SDI interface (HD, 3G, 6G, and 12G-SDI).

	Format	Cables	Hres	Vres	Frame rate (Hz)	Sampling	Bit-depth
HD	1280x720	2x	1280	720	24, 25, 30, 60	4:2:2	10bpc
	1920x1080	2x	1920	1080	24, 25, 30	4:2:2	10bpc
	2048x1080	2x	2048	1080	24, 25, 30	4:2:2	10bpc
3G	1280x720	2x	1280	720	24, 25, 30, 60	RGB/4:4:4	10/12bpc
	1920x1080	2x	1920	1080	24, 25, 30	RGB/4:4:4	10/12bpc
	1920x1080	2x	1920	1080	60	4:2:2	10bpc
	2048x1080	2x	2048	1080	24, 25, 30	RGB/4:4:4	10/12bpc
	2048x1080	2x	2048	1080	60	4:2:2	10bpc
6G	1920x1080	2x	1920	1080	60	RGB/4:4:4	10/12bpc
	2048x1080	2x	2048	1080	60	RGB/4:4:4	10/12bpc
	3840x2160	2x	3840	2160	24, 25, 30	4:2:2	10bpc
	4096x2160	2x	4096	2160	24, 25, 30	4:2:2	10bpc
12G	3840x2160	2x	3840	2160	24, 25, 30	RGB/4:4:4	10/12bpc
	3840x2160	2x	3840	2160	60	4:2:2	10bpc
	4096x2160	2x	4096	2160	24, 25, 30	RGB/4:4:4	10/12bpc
	4096x2160	2x	4096	2160	60	4:2:2	10bpc

TDPIC

The DisplayPort 1.1a interface supports HDCP 1.x.

	Format	Cables	Hres	Vres	Frame rate (Hz)	Sampling	Bit-depth	Notes
HD	1280x720	2x	1280	720	24, 25, 30, 60	RGB/4:4:4	8/10bpc	—
	1920x1080	2x	1920	1080	24, 25, 30, 60	RGB/4:4:4	8/10bpc	—
	2048x1080	2x	2048	1080	24, 25, 30, 60	RGB/4:4:4	8/10bpc	—
4K	3840x2160	2x	3840	2160	24, 25, 30	RGB/4:4:4	8/10bpc	Cannot use both TDPIC inputs at once; requires two separate TDPICs
	4096x2160	2x	4096	2160	24, 25, 30	RGB/4:4:4	8/10bpc	Cannot use both TDPIC inputs at once; requires two separate TDPICs

	Format	Cables	Hres	Vres	Frame rate (Hz)	Sampling	Bit-depth	Notes
	3840x2160	4x	1920	2160	60	RGB/4:4:4	8/10bpc	Cannot use both TDPIC inputs at once; requires four separate TDPICs
	4096x2160	4x	2048	2160	60	RGB/4:4:4	8/10bpc	Cannot use both TDPIC inputs at once; requires four separate TDPICs
	3840x2160	8x	1920	1080	60	RGB/4:4:4	8/10bpc	—
	4096x2160	8x	2048	1080	60	RGB/4:4:4	8/10bpc	—

DDIC

The DVI-D interface supports HDCP 1.x.

	Format	Cables	Hres	Vres	Frame rate (Hz)	Sampling	Bit-depth	Notes
HD	1280x720	2x	1280	720	60	RGB/4:4:4	8bpc	—
	1920x1080	2x	1920	1080	24, 25, 30, 60	RGB/4:4:4	8bpc	—
	2048x1080	2x	2048	1080	24, 25, 30, 60	RGB/4:4:4	8bpc	—
4K	3840x2160	2x	3840	2160	24, 25, 30	RGB/4:4:4	8bpc	Dual-link
	4096x2160	2x	4096	2160	24, 25, 30	RGB/4:4:4	8bpc	Dual-link
	3840x2160	4x	1920	2160	60	RGB/4:4:4	8bpc	Dual-link
	4096x2160	4x	2048	2160	60	RGB/4:4:4	8bpc	Dual-link

THIC

The HDMI 1.4 interface supports HDCP 1.x.

	Format	Cables	Hres	Vres	Frame rate (Hz)	Sampling	Bit-depth
HD	1280x720	2x	1280	720	24, 25, 30, 60	RGB/4:4:4/4:2:2	8/10/12bpc
	1920x1080	2x	1920	1080	24, 25, 30, 60	RGB/4:4:4/4:2:2	8/10/12bpc
	2048x1080	2x	2048	1080	24, 25, 30, 60	RGB/4:4:4/4:2:2	8/10/12bpc
4K	3840x2160	8x	1920	1080	24, 25, 30, 60	RGB/4:4:4/4:2:2	8/10/12bpc
	4096x2160	8x	2048	1080	24, 25, 30, 60	RGB/4:4:4/4:2:2	8/10/12bpc

3GIC (HD and 3G-SDI)

	Format	Cables	Hres	Vres	Frame rate (Hz)	Sampling	Bit-depth	Notes
HD	1280x720	2x	1280	720	24, 25, 30, 60	4:2:2	10bpc	—
	1920x1080	2x	1920	1080	24, 25, 30	4:2:2	10bpc	—
	2048x1080	2x	2048	1080	24, 25, 30	4:2:2	10bpc	—
3G	1280x720	2x	1280	720	24, 25, 30, 60	RGB/4:4:4	10/12bpc	Level-A recommended
	1920x1080	2x	1920	1080	24, 25, 30	RGB/4:4:4	10/12bpc	Level-A recommended
	1920x1080	2x	1920	1080	60	4:2:2	10bpc	Level-A recommended
	2048x1080	2x	2048	1080	24, 25, 30	RGB/4:4:4	10/12bpc	Level-A recommended
	2048x1080	2x	2048	1080	60	4:2:2	10bpc	Level-A recommended
3G-4K	3840x2160	8x	1920	1080	24, 25, 30	RGB/4:4:4	10/12bpc	Level-A recommended
	3840x2160	8x	2048	1080	60	4:2:2	10bpc	Level-A recommended
	4096x2160	8x	1920	1080	24, 25, 30	RGB/4:4:4	10/12bpc	Level-A recommended
	4096x2160	8x	2048	1080	60	4:2:2	10bpc	Level-A recommended

Regulatory

This product conforms to the latest regulations and standards related to product safety, environmental, and electromagnetic compatibility (EMC) requirements.

Safety

- ANSI/UL 60950-1 – Information Technology Equipment – Safety – Part 1: General Requirements
- CAN/CSA C22.2 No. 60950-1-07 – Information Technology Equipment – Safety – Part 1: General Requirements
- IEC/EN 60825-1 – Safety of Laser Products – Part 1: Equipment Classification and Requirements
- IEC/EN 62471-5 – Photobiological safety of lamps and lamp systems – Part 5: Image projectors
- UL 60950-1 – Information Technology Equipment – Safety – Part 1: General Requirements

Electro-magnetic compatibility

Emissions

- CAN ICES-003 (A)/NMB-003 (A) – Information Technology Equipment (Including Digital Apparatus) – Limits and Methods of Measurement
- CISPR 32:2012/EN 55032:2012, Class A – Electromagnetic Compatibility of Multimedia Equipment – Emission Requirements
- FCC CFR47, Part 15, Subpart B, Class A – Unintentional Radiators
- IEC 61000-3-11/EN61000-3-11: Limitations of Voltage Changes, Voltage Fluctuations, and Flicker for equipment with rated current ≤ 75 A
- IEC 61000-3-12/EN61000-3-12: Limits for harmonic current emissions for equipment for systems with input current > 16 A and ≤ 75 A per phase

Immunity

- CISPR 24:2010/EN55024:2010 EMC Requirements – Information Technology Equipment – Immunity Characteristics – Limits and Methods of Measurements

Environmental

- China Ministry of Information Industry (along with 7 other Government Agencies) Order No.32 (01/2016) on the control of pollution caused by electronic information products, hazardous

substances concentration limits (GB/T 26572 - 2011), and the applicable product marking requirement (SJ/T 11364 - 2014).

- EU Directive (2011/65/EU) on the restriction of the uses of certain hazardous substances (RoHS) in electrical and electronic equipment and the applicable official amendment(s).
- EU Directive (2012/19/EU) on waste and electrical and electronic equipment (WEEE) and the applicable official amendment(s).
- Regulation (EC) No. 1907/2006 on the registration, evaluation, authorization and restriction of chemicals (REACH) and the applicable official amendment(s).

