The top half of the page features a complex, abstract background of overlapping, semi-transparent blue triangles and polygons in various shades of blue, creating a dynamic, crystalline effect. This pattern transitions into a clean white background at the bottom.

Installation and Setup Guide
020-103746-04

CP4445-RGB and CP4455- RGB

CHRISTIE®

NOTICES

COPYRIGHT AND TRADEMARKS

Copyright © 2023 Christie Digital Systems USA Inc. All rights reserved.

All brand names and product names are trademarks, registered trademarks or trade names of their respective holders.

GENERAL

Every effort has been made to ensure accuracy, however in some cases changes in the products or availability could occur which may not be reflected in this document. Christie reserves the right to make changes to specifications at any time without notice. Performance specifications are typical, but may vary depending on conditions beyond Christie's control such as maintenance of the product in proper working conditions. Performance specifications are based on information available at the time of printing. Christie makes no warranty of any kind with regard to this material, including, but not limited to, implied warranties of fitness for a particular purpose. Christie will not be liable for errors contained herein or for incidental or consequential damages in connection with the performance or use of this material. Our centers of excellence for manufacturing in Kitchener, Ontario, Canada and in Shenzhen, China are ISO 9001:2015 Quality Management System-certified.

Christie is committed to making our documents free from language bias; however, we are not responsible for the language used on any linked or third-party documentation.

For the most current technical documentation and office contact information, visit <http://www.christiedigital.com>.

Warranty

Products are warranted under Christie's standard limited warranty, the details of which are available at <https://www.christiedigital.com/help-center/warranties/> or by contacting your Christie dealer or Christie.

PREVENTATIVE MAINTENANCE

Preventative maintenance is an important part of the continued and proper operation of your product. Failure to perform maintenance as required, and in accordance with the maintenance schedule specified by Christie, voids the warranty. For preventative maintenance schedules, refer to www.christiedigital.com.

REGULATORY

The product has been tested and found to comply with the limits for a Class A digital device, pursuant to Part 15 of the FCC Rules. These limits are designed to provide reasonable protection against harmful interference when the product is operated in a commercial environment. The product generates, uses, and can radiate radio frequency energy and, if not installed and used in accordance with the instruction manual, may cause harmful interference to radio communications. Operation of the product in a residential area is likely to cause harmful interference in which case the user will be required to correct the interference at the user's own expense. Changes or modifications not expressly approved by the party responsible for compliance could void the user's authority to operate the equipment

CAN ICES-3 (A) / NMB-3 (A)

이 기기는 업무용(A급)으로 전자파적합등록을 한 기기이오니 판매자 또는 사용자는 이점을 주의하시기 바라며, 가정 외의 지역에서 사용하는 것을 목적으로 합니다.

ENVIRONMENTAL



The product is designed and manufactured with high-quality materials and components that can be recycled and reused. This symbol  means electrical and electronic equipment, at their end-of-life, should be disposed of separately from regular waste. Please dispose of the product appropriately and according to local regulations. In the European Union, separate collection systems are for used electrical and electronic products.

If printing this document, consider printing only the pages you need and select the double-sided option.

Please help us to conserve the environment we live in!

Notation

Learn the hazard and information symbols used in the product documentation.



Danger messages indicate a hazardous situation which, if not avoided, results in death or serious injury.



Warning messages indicate a hazardous situation which, if not avoided, could result in death or serious injury.



Caution messages indicate a hazardous situation which, if not avoided, could result in minor or moderate injury.



Notice messages indicate a hazardous situation which, if not avoided, may result in equipment or property damage.



Information messages provide additional information, emphasize or provide a useful tip.

Content

Introduction.	6
Product documentation.	6
Related documentation.	6
Safety precautions.	7
General safety precautions.	7
Laser safety precautions.	7
AC/power precautions.	8
Light intensity hazard distance.	8
Product labels.	14
General hazards.	14
Mandatory action.	14
Electrical labels.	15
Additional hazard labels.	15
Contact your dealer.	16
Key features.	16
List of components.	16
Accessories.	17
CineMaster cinema calculator tool.	20
Technical support.	20
Installing and setting up.	21
Site requirements.	21
Power specifications.	22
Projector components.	23
Chiller components.	24
Teyu 6200 chiller components.	25
SMC HRS-040 chiller components.	26
Preparing the installation site.	26
Lifting and positioning the projector.	27
Connecting to power.	29
Connecting to an uninterruptible power supply.	33
Installing the lens.	35
Projector power modes.	37
Using the Remote user interface (UI).	38

Setting up the chiller unit.	38
Setting up the Teyu chiller unit.	38
Setting up the SMC chiller unit.	46
Setting the chiller setpoint.	54
Maintaining the chiller.	55
System operation for CP4445-RGB and CP4455-RGB projectors only.	55
Turning on or off the projector.	55
Logging into the projector.	56
Turning on or off the light source.	56
Activating marriage.	56
Disposing of the product packaging.	57
Completing the installation checklist.	57
Video Input panel.	58
HDMI video source.	59
HDMI video formats.	59
SDI video source.	61
SDI video formats.	61
DisplayPort video source.	67
DisplayPort video formats.	67
Integrated Media Block (IMB) video source.	68
Series 2 Integrated Media Block (IMB) video formats.	69
Series 4 Integrated Media Block (IMB) video formats.	70
HDMI video source connection from an Integrated Media Block (IMB).	73
SDI video source connection from an Integrated Media Block (IMB).	73
GPIO connector.	73
Managing the light source.	76
Creating a new laser file for external chiller-based projectors.	76
Modifying an existing laser file.	77
Copying existing laser settings to a new file.	78
Deleting a laser file.	78
LiteLOC™ sensor-to-screen calibration	78
LiteLOC™ sensor-to-screen calibration: Workflow.	79
Creating a new calibration file.	79
Recalibrating an existing calibration file.	80
Editing the existing calibration file parameters.	81
Verifying the sensor-to-screen calibration	82
Adding a calibration file to the Channel Setup.	82

Adjusting the image. 83

- Calibrating the Intelligent Lens System. 83
- Correcting vignetting. 83
- Adjusting tilt and leveling the projector. 83
- Correcting keystone effect. 84
- Displaying a test pattern. 85
- Adjusting the integrator rod and fold mirror. 85
- Adjusting boresight 88
- Adjusting digital micromirror device (DMD) convergence. 91
 - Mechanically adjusting digital micromirror device (DMD) convergence. 91
 - Electronically adjusting convergence. 93

Regulatory. 96

- Safety. 96
- Electro-magnetic compatibility. 96
 - Emissions. 96
 - Immunity. 97
- California law on security. 97
- Environmental. 97

Introduction

This manual is intended for professionally trained operators of Christie high-brightness CP4445-RGB and CP4455-RGB projection systems.

For complete product documentation and technical support, go to www.christiedigital.com.

Product documentation

For installation, setup, and user information, see the product documentation available on the Christie Digital Systems USA Inc. website. Read all instructions before using or servicing this product.

1. Access the documentation from the Christie website:
 - Go to this URL: <https://bit.ly/3vxrm4Y> or <https://www.christiedigital.com/products/cinema/projection/cinelifepus-series/>.
 - Scan the QR code using a QR code reader app on a smartphone or tablet.



2. On the product page, select the model and switch to the **Downloads** tab.

Related documentation

Additional information on the projector is available in the following documents.

- *CineLife+ User Guide (P/N: 020-103073-XX)*
- *CP4445-RGB and CP4455-RGB Product Safety Guide (P/N: 020-103745-XX)*
- *CP4445-RGB and CP4455-RGB Service Guide (P/N: 020-103758-XX)*
- *CineLife+ Serial Commands Guide (P/N: 020-103075-XX)*

Safety precautions

Learn about the safety precautions related to the Christie CP4445-RGB and CP4455-RGB projector. This projector is intended for use in a cinema environment.

General safety precautions

Read all safety and warning guidelines before installing or operating the projector.



Warning! If not avoided, the following could result in death or serious injury.

- TRIP OR FIRE HAZARD! Position all cables where they cannot contact hot surfaces, be pulled, be tripped over, or damaged by persons walking on or objects rolling over the cables.
- This product must be installed within a restricted access location not accessible by the general public.
- Only personnel who are trained on the precautions for the restricted access location can be granted entry to the area.
- Install the product so users and the audience cannot enter the restricted area at eye level.
- ELECTRICAL and BURN HAZARD! Use caution when accessing internal components.
- High leakage current. Earth or ground connection essential before connecting power.
- FIRE AND SHOCK HAZARD! Use only the attachments, accessories, tools, and replacement parts specified by Christie.
- FIRE HAZARD! Do not use a power cord, harness, or cable that appears damaged.
- HAZARDOUS SUBSTANCE! Use caution when handling the product as it contains ethylene glycol. Do not ingest coolant. For information on safe handling, refer to the Safety Data Sheet (SDS) for the coolant.
- Lift equipment must be used to position the product.
- Do not install or operate the projector in any position that does not meet the stated product specifications for alignment and orientation.



Caution! If not avoided, the following could result in minor or moderate injury.

- Only Christie qualified technicians are permitted to open product enclosures.

Laser safety precautions

Read all safety and warning guidelines before operating the projector laser.



Warning! If not avoided, the following could result in death or serious injury.

- Do not operate the cinema projector without all of its covers in place.
- LASER RADIATION HAZARD! This projector has a built-in Class 4 laser module. Never attempt to disassemble or modify the laser module.
- RADIATION HAZARD! Use of controls or adjustments, or performing procedures other than those specified may result in hazardous radiation exposure.
- Do not look directly into the lens when the light source is on. The extremely high brightness can cause permanent eye damage.
- Possible hazardous optical radiation emitted from this product. (Risk group 3)

AC/power precautions

Read all safety and warning guidelines before connecting to AC power.



Warning! If not avoided, the following could result in death or serious injury.

- SHOCK HAZARD! Only use the AC power cord provided with the product or recommended by Christie.
- FIRE AND SHOCK HAZARD! Do not attempt operation unless the power cord, power socket, and power plug meet the appropriate local rating standards.
- SHOCK HAZARD! Do not attempt operation if the AC supply is not within the specified voltage and current, as specified on the license label.
- SHOCK HAZARD! The optional UPS power cord must be inserted into an outlet with grounding.
- SHOCK HAZARD! A dedicated, protected ground or earth wire must be installed on the product by Christie qualified technicians or electricians before it can be connected to power.
- SHOCK HAZARD! Disconnect the product from AC before installing, moving, servicing, cleaning, removing components, or opening any enclosure.
- Install the product near an easily accessible AC receptacle.
- Always connect the ground or earth first to reduce shock hazard.
- A certified electrician must be present during installation to make sure the installation meets the local electrical code.



Caution! If not avoided, the following could result in minor or moderate injury.

- Use an appropriately sized strain relief connector with the knockout plate provided, to make sure adequate environmental sealing and to prevent the AC supply cable from accidentally being torn out or rubbing against the knockout plate.
- FIRE HAZARD! Do not use a power cord, harness, or cable that appears damaged.
- FIRE OR SHOCK HAZARD! Do not overload power outlets and extension cords.
- SHOCK HAZARD! Power supply uses double pole/neutral fusing.

Light intensity hazard distance

This projector has been classified as Risk Group 3 as per the IEC 62471-5:2015 standard due to possible hazardous optical and thermal radiation being emitted.



Warning! If not avoided, the following could result in serious injury.

- PERMANENT/TEMPORARY BLINDNESS HAZARD! No direct exposure to the beam must be permitted. Class 1 Laser Product - Risk Group 3 according to IEC 60825-1:2014 and IEC 62471-5:2015.
- PERMANENT/TEMPORARY BLINDNESS HAZARD! Operators must control access to the beam within the hazard distance or install the product at the height that prevents exposure of spectators' eyes within the hazard distance. The hazard zone must be no lower than 2.5 meters/8.2 feet (US installations) or 2.0 meters/6.6 feet (global installations) above any surface upon which any persons are permitted to stand and the horizontal clearance to the hazard zone must be a minimum 1.0 meters.
- EXTREME BRIGHTNESS! Do not place reflective objects in the product light path.

The following show the zones for ocular and skin hazard distances.

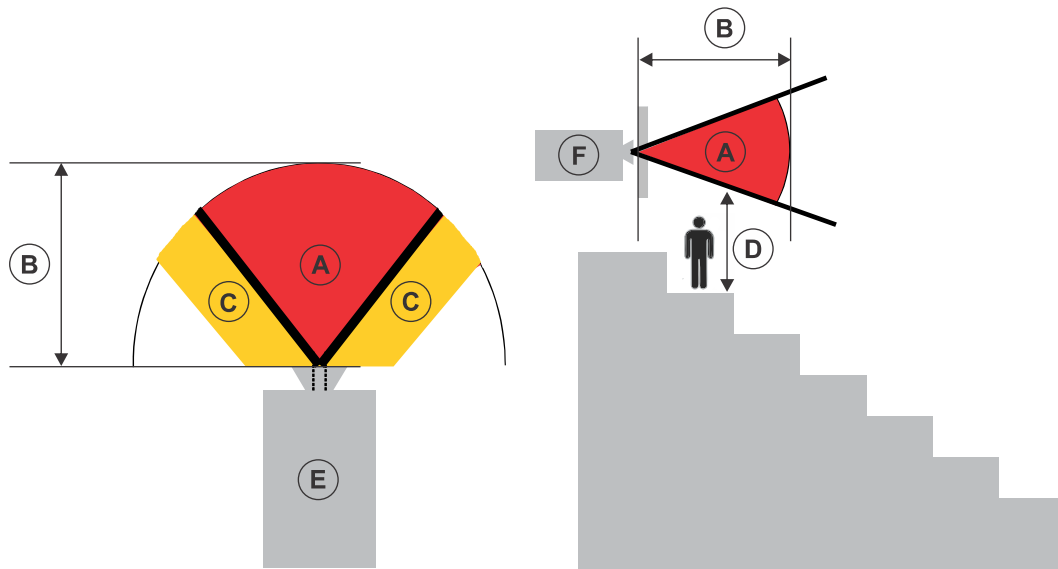

- A—Hazard zone. The region of space where the projection light from the laser-illuminated projector is above emission limits for Risk Group 2. The light intensity may cause eye damage after a momentary or brief exposure (before a person can avert their eyes away from the light source). The light may cause skin burns to occur.
- B—Hazard distance. Operators must control access to the beam within the hazard distance or install the product preventing potential exposure of the spectators' eyes from being in the hazard distance.
- C—No access zone. Horizontal clearance of the no access zone must be a minimum of 1.0 meters (3.3 feet).
- D—Vertical distance to hazard zone. The hazard zone must be no lower than 2.5 meters/8.2 feet (US installations) or 2.0 meters/6.6 feet (global installations) above any surface upon which any persons are permitted to stand.
If the vertical distance to hazard zone requirement (Zone D) is satisfied, the horizontal clearance distance (Zone C) is not needed.
- E—Represents the top view of the projector.
- F—Represents the side view of the projector.

For US and international hazard distances based upon IEC 62471-5:2015, *Photobiological safety of lamps and lamp systems – Part 5: Image projectors*.

Projection lens	Part number	Notes
High brightness fixed		
0.9:1	38-809071-XX	—
High brightness zoom		
1.13-1.66:1	108-342100-XX	—
1.31-1.85:1	108-335102-XX	—
1.45-2.17:1	108-336103-XX	—
1.63-2.71:1	108-337104-XX	—

Projection lens	Part number	Notes
1.95-3.26:1	108-338105-XX	—
2.71-3.89:1	108-278101-XX	—
3.89-5.43:1	108-279101-XX	CP4445-RGB—Requires a 185 mm lens hood extension (P/N: 163-168106-XX) to use with this product. CP4455-RGB—Requires a 260 mm lens hood extension (P/N: 163-180100-XX) to use with this product.
4.98-7.69:1	108-280101-XX	CP4445-RGB—Requires a 410 mm lens hood extension (P/N: 163-167105-XX) to use with this product. CP4455-RGB—Requires a 530 mm lens hood extension (P/N: 163-181101-XX) to use with this product.
High brightness premium zoom		
1.13-1.72:1	163-141107-XX	—
1.35-1.84:1	163-142108-XX	—
1.45-2.10:1	163-143109-XX	—
1.65-2.70:1	163-144100-XX	—
High contrast zoom		
1.13-1.66:1	152-117100-XX	—
1.31-1.85:1	152-118101-XX	—
1.45-2.17:1	152-119102-XX	—
1.63-2.71:1	152-120104-XX	—
1.95-3.26:1	108-404109-XX	—
High contrast premium zoom		
1.13-1.72:1	152-155102-XX	—
1.35-1.84:1	152-156103-XX	—
1.45-2.10:1	152-157104-XX	—
1.65-2.70:1	152-158105-XX	—
Ultra-high contrast fixed		
0.9:1	163-117100-XX	—
Ultra-high contrast zoom		
1.13-1.66:1	163-103105-XX	—

Projection lens	Part number	Notes
1.31-1.85:1	163-104106-XX	—
1.45-2.17:1	163-105107-XX	—
1.63-2.71:1	163-106108-XX	—
1.95-3.26:1	163-107109-XX	—
2.71-3.89:1	163-108100-XX	—
3.89-5.43:1	163-109101-XX	CP4445-RGB—Requires a 185 mm lens hood extension (P/N: 163-168106-XX) to use with this product. CP4455-RGB—Requires a 260 mm lens hood extension (P/N: 163-180100-XX) to use with this product.
4.98-7.69:1	163-110103-XX	CP4445-RGB—Requires a 410 mm lens hood extension (P/N: 163-167105-XX) to use with this product. CP4455-RGB—Requires a 530 mm lens hood extension (P/N: 163-181101-XX) to use with this product.
Ultra-high contrast premium zoom		
1.13-1.72:1	163-145101-XX	—
1.35-1.84:1	163-146102-XX	—
1.45-2.10:1	163-147103-XX	—
1.65-2.70:1	163-148104-XX	—

The following gives the hazard distance for the projector lens with the zoom adjusted to its most hazardous position for CP4445-RGB high brightness, high contrast, and ultra-high contrast lenses.

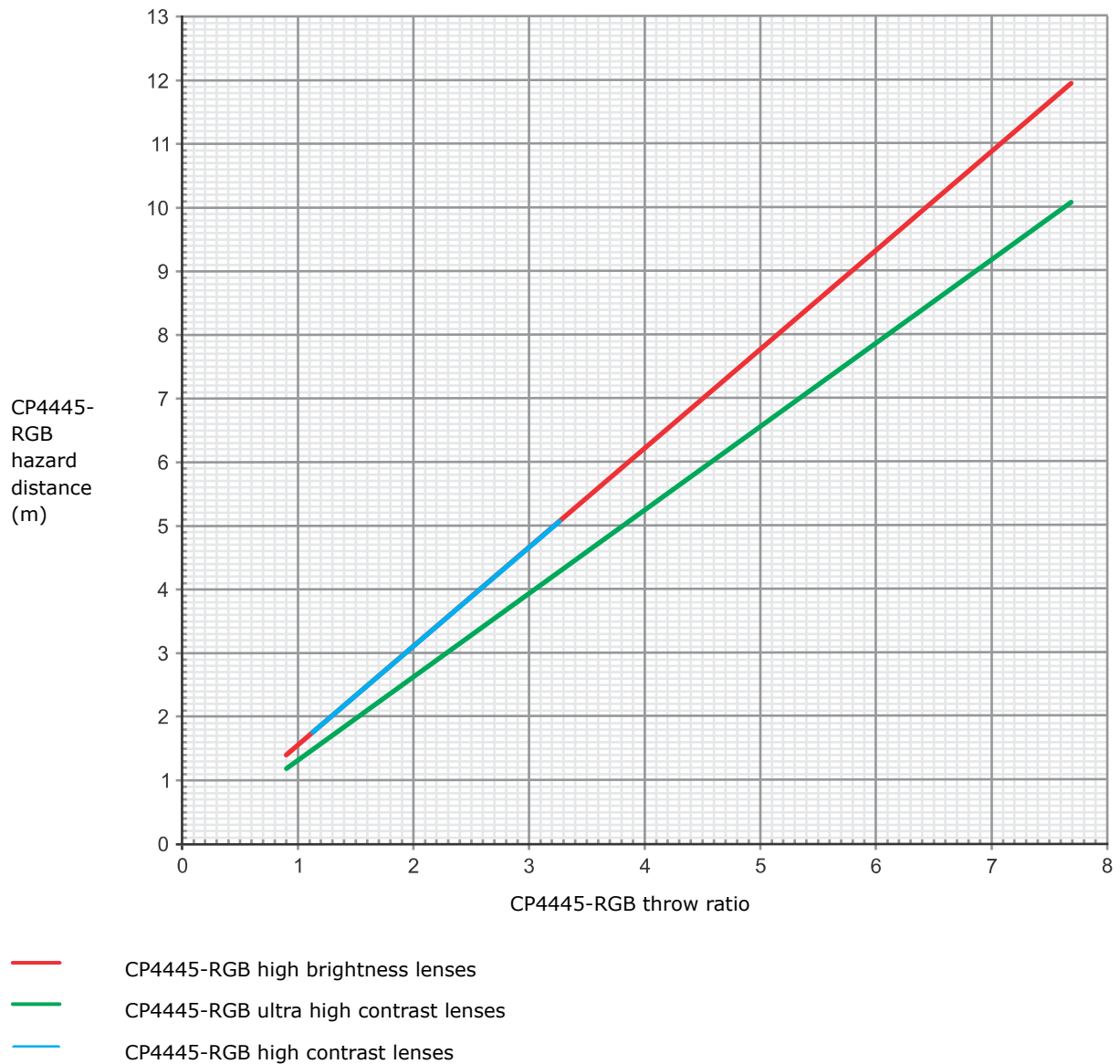

The following gives the hazard distance for the projector lens with the zoom adjusted to its most hazardous position for CP4455-RGB high brightness, high contrast, and ultra-high contrast lenses.

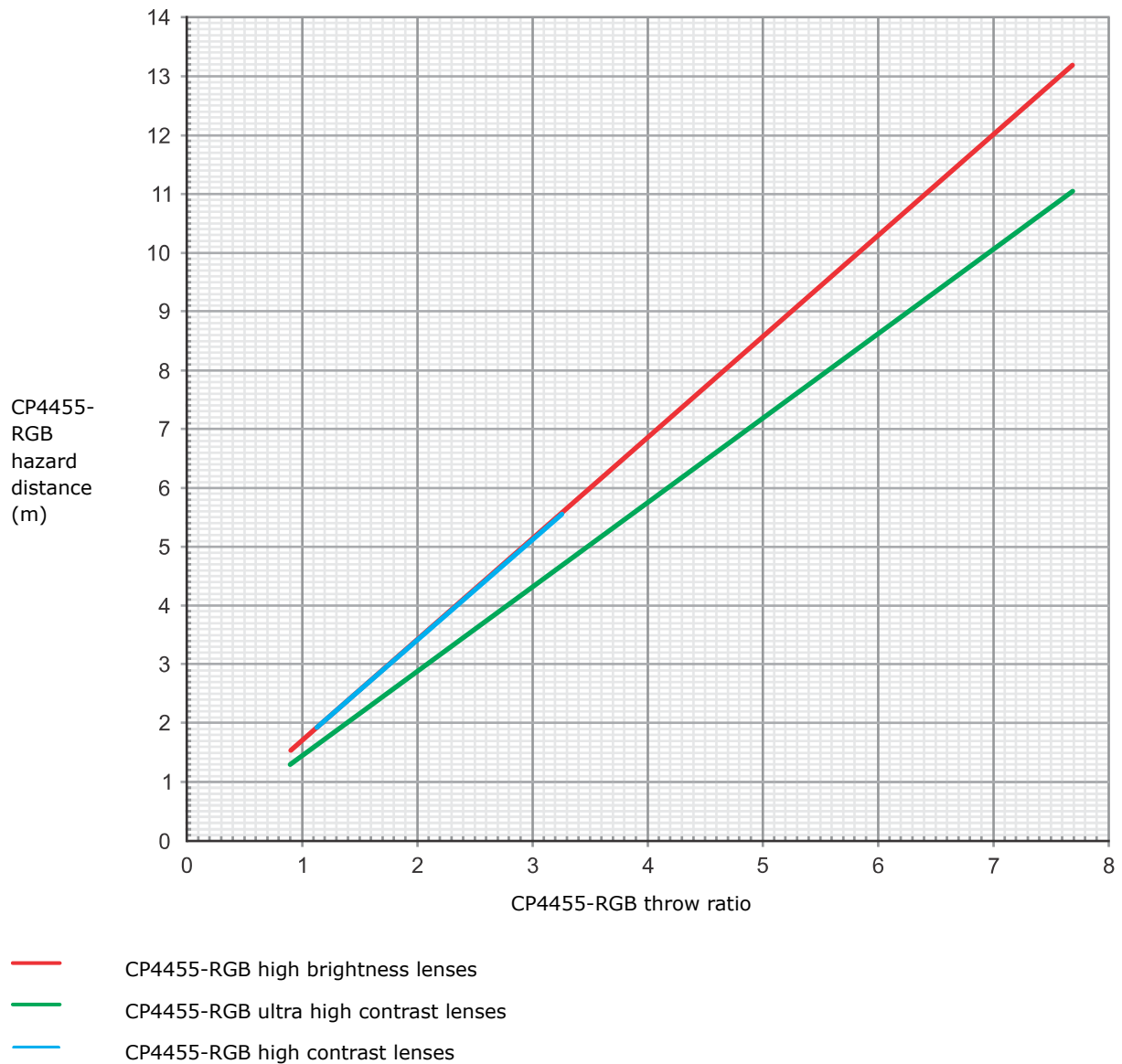

For Installations in the United States

The following must be in place for laser-illuminated projector installations in the United States:



- The projection room shall be clearly identified by the posting of laser warning and restricted access signs, and by restricting entry through physical means. The projection room sign must display the warning "No direct exposure to beam shall be permitted".
- The Christie Laser Projection System Installation Checklist must be fully completed after the installation and sent to *lasercompliance@christiedigital.com*. A copy can remain on-site. This checklist can be found as a separate document in the accessory box with the manual.
- Certain US states have additional laser regulatory requirements. Contact *lasercompliance@christiedigital.com* for additional regulatory requirements.

Product labels

Learn about the labels that may be used on the product. Labels on your product may be yellow or black and white.

General hazards

Hazard warnings also apply to accessories once they are installed in a Christie product connected to power.

Fire and Shock Hazard	
	<p>To prevent fire or shock hazards, do not expose this product to rain or moisture.</p> <p>Do not alter the power plug, overload the power outlet, or use it with extension cords.</p> <p>Do not remove the product enclosure.</p> <p>Only Christie qualified technicians are authorized to service the product.</p>
Electrical Hazard	
	<p>Risk of electric shock.</p> <p>Do not remove the product enclosure.</p> <p>Only Christie qualified technicians are authorized to service the product.</p>



Warning! If not avoided, the following could result in death or serious injury.



Electric shock hazard. To avoid personal injury, disconnect all power sources before performing maintenance or service.



Electrocution hazard. To avoid personal injury, always disconnect all power sources before performing maintenance or service procedures.



Laser hazard. To avoid personal injury, avoid eye or skin exposure to direct or scattered radiation.



Notice. If not avoided, the following could result in property damage.

Mandatory action



Caution! If not avoided, the following could result in minor or moderate injury.



Consult the service manual.



SHOCK HAZARD! Disconnect all power sources before performing maintenance or service procedures.

Electrical labels



Indicates the presence of a protective earth ground.



Indicates the presence of an earth ground.

Additional hazard labels



Indicates Class 4 laser radiation when open. Avoid eye or skin exposure to direct or scattered radiation.



CLASS 1 LASER PRODUCT IEC 60825-1:2014

Wavelengths:

CP4445-RGB: 450 nm - 660 nm

CP4455-RGB: 450 nm - 660 nm

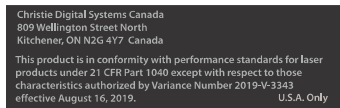

FDA laser variance (US projectors only). This product is in conformity with performance standards for laser products under 21 CFR 1040, except with respect to those characteristics authorized by Variance Number 2019-V-3343 effective on August 16, 2019.



Indicates a light hazard. Do not look directly into the lens. The extreme high brightness can cause permanent eye damage. Class 1 Laser Product - Risk Group 3 according to IEC 60825-1:2014 and IEC 62471-5:2015.



Indicates high leakage current. Earth or ground connection essential before connecting the power supply.

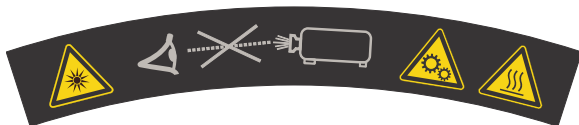

Indicates a light hazard. Do not look directly into the lens. The extreme high brightness can cause permanent eye damage.

Indicates moving parts hazard for the motorized lens mount. To avoid personal injury, keep hands clear and clothing tied back.

Indicates a hot surface hazard when certain lenses are installed and the projector is operated at full brightness for extended periods of time. To avoid injury, allow the lens to cool before removing.

Contact your dealer

Record the information about your installation and keep this information with your records to assist with any servicing of your product. If you encounter a problem, contact your dealer.

Purchase record
Dealer:
Dealer or Christie Sales/Service contact phone number:
Serial number: The serial number can be found on the license label.
Purchase date:
Installation date:

Key features

Understand the important features of the projector.

- For all CineLife+™ projectors:
 - Christie CineLife+™ electronics platform for ultra-fast processing
 - High frame rate playback of 4K at 120 Hz, for premium, large format cinema venues
 - Ability to work with Mystique software
 - 4K 3D playback capability
 - Compatible with ultra-high contrast (UHC) lens suite
- For all CineLife+™ laser projectors:
 - Solid-state Christie RealLaser™ RGB laser illumination
 - Three-chip 1.38 inch 4K DLP™ light engine or three-chip 0.98 inch 2K DLP™ light engine
 - Integrated direct-coupled laser modules in the projector chassis (dual direct-coupled laser modules in CP4445-RGB and CP4455-RGB projectors)
 - LiteLOC™ color lock feature for constant image brightness and color
 - External chiller unit with exhaust adapter (CP4445-RGB and CP4455-RGB projectors only)

List of components

Verify all components were received with the projector.

- Touch panel, touch panel harness, and panel mounting arm
- High security key to open the projector service access door

- Teyu chiller CW-6200AN—50Hz (P/N: 163-124108-XX)
- Teyu chiller CW-6200AN—60Hz (P/N: 163-136101-XX)
- Teyu chiller setup kit plumbing (P/N: 163-149105-XX)
- Teyu chiller setup kit air ducts (P/N: 163-150107-XX)
- SMC HRS040 chiller (P/N: 163-186106-XX)
- SMC HRS040 chiller assembly (P/N: 163-185105-XX)
- SMC HRS040 chiller connection kit for CP44XX-RGB (P/N: 163-187107-XX)
- 10 Foot High-pressure Hose kit (P/N: 163-184104-XX)
- 15 Foot High-pressure Hose kit (P/N: 163-183103-XX)
- 30 Foot High-pressure Hose kit (P/N: 163-182102-XX)
- Coolant propylene glycol (P/N: 003-006744-XX)
- Optional PLF Cinema pedestal (P/N: 163-126100-XX)

An optional UPS inlet power cord is also available.

Accessories

Learn about the accessories (sold separately) available for the projector.

Lenses

Projection lens	Part number	Notes
High brightness fixed		
0.9:1	38-809071-XX	—
High brightness zoom		
1.13-1.66:1	108-342100-XX	—
1.31-1.85:1	108-335102-XX	—
1.45-2.17:1	108-336103-XX	—
1.63-2.71:1	108-337104-XX	—
1.95-3.26:1	108-338105-XX	—
2.71-3.89:1	108-278101-XX	—
3.89-5.43:1	108-279101-XX	CP4445-RGB—Requires a 185 mm lens hood extension (P/N: 163-168106-XX) to use with this product. CP4455-RGB—Requires a 260 mm lens hood extension (P/N: 163-180100-XX) to use with this product.
4.98-7.69:1	108-280101-XX	CP4445-RGB—Requires a 410 mm lens hood extension (P/N:

Projection lens	Part number	Notes
		163-167105-XX) to use with this product. CP4455-RGB—Requires a 530 mm lens hood extension (P/N: 163-181101-XX) to use with this product.
High brightness premium zoom		
1.13-1.72:1	163-141107-XX	—
1.35-1.84:1	163-142108-XX	—
1.45-2.10:1	163-143109-XX	—
1.65-2.70:1	163-144100-XX	—
High contrast zoom		
1.13-1.66:1	152-117100-XX	—
1.31-1.85:1	152-118101-XX	—
1.45-2.17:1	152-119102-XX	—
1.63-2.71:1	152-120104-XX	—
1.95-3.26:1	108-404109-XX	—
High contrast premium zoom		
1.13-1.72:1	152-155102-XX	—
1.35-1.84:1	152-156103-XX	—
1.45-2.10:1	152-157104-XX	—
1.65-2.70:1	152-158105-XX	—
Ultra-high contrast fixed		
0.9:1	163-117100-XX	—
Ultra-high contrast zoom		
1.13-1.66:1	163-103105-XX	—
1.31-1.85:1	163-104106-XX	—
1.45-2.17:1	163-105107-XX	—
1.63-2.71:1	163-106108-XX	—
1.95-3.26:1	163-107109-XX	—
2.71-3.89:1	163-108100-XX	—
3.89-5.43:1	163-109101-XX	CP4445-RGB—Requires a 185 mm lens hood extension (P/N: 163-168106-XX) to use with this product. CP4455-RGB—Requires a 260 mm lens hood extension (P/N:

Projection lens	Part number	Notes
		163-180100-XX) to use with this product.
4.98-7.69:1	163-110103-XX	CP4445-RGB—Requires a 410 mm lens hood extension (P/N: 163-167105-XX) to use with this product. CP4455-RGB—Requires a 530 mm lens hood extension (P/N: 163-181101-XX) to use with this product.
Ultra-high contrast premium zoom		
1.13-1.72:1	163-145101-XX	—
1.35-1.84:1	163-146102-XX	—
1.45-2.10:1	163-147103-XX	—
1.65-2.70:1	163-148104-XX	—

UPS power cords

Description	Part Number
North America black 9.83 125V/15A	108-382104-XX
Japan 125V/12A C13 2.5 m	108-371102-XX
China 250V/10A C13 3.0 m	108-373104-XX
UK 250V/10A C13 2.5 m	108-388100-XX
Europe/Korea 250V/10A C13 2.5 m	108-390103-XX
South Africa 250V/10A C13 2.5 m	108-487100-XX
Europe 250V/10A C13 2.5 m	108-604101-XX
Australia 250V/10A C13 2.5 m	108-435103-XX

Filters and coolant

Description	Part number
Light engine air filter (6 pack)	003-006464-XX 003-007282-XX
Air intake filter (4 pack)	003-006819-XX
Coolant propylene glycol 10L	003-006744-XX

Other accessories

Description	Part number
Motorized zoom kit (Series II)	003-103912-XX
Touch screen monitor	003-121784-XX
Touch panel harness	003-121785-XX
Driver set	003-007010-XX

CineMaster cinema calculator tool

The CineMaster cinema calculator tool helps you calculate and configure the optimal cinema set up. Use this tool to help determine the right projector, lens, and lamp based on the unique needs of your installation, as well as your preferred projector type, screen configuration, and brightness requirements.

<https://cinemaster.christiedigital.com/>

Technical support

Technical support for Christie Cinema products is available at:

- Support.cinema@christiedigital.com
- +1-877-334-4267
- Christie Professional Services: +1-800-550-3061 or NOC@christiedigital.com

Installing and setting up

Learn how to position and install the projector.

Site requirements

To safely install and operate CP4445-RGB and CP4455-RGB projectors, the installation location must meet these minimum requirements.

Physical operating environment

- Ambient temperature (operating) 10 to 35°C (50 to 95°F)
- Humidity (non-condensing) 10% to 80%
- Operating altitude 0 to 3000 meters (0 to 9843 feet)
- Site cleanliness: ISO Class 9 or cleaner

Projector exhaust ducting

Sufficient ventilation is required around the projector to regulate the temperature of the projector electronics and optical components.

The projector has an 20.3 cm (8 inches) built-in exhaust duct. Exhaust HVAC ducts can be connected to the projector to achieve optimal performance.

The installation site must provide an airflow 450 cubic feet per minute (CFM) at 1 to 1000 meters (3.3 to 3280.8 feet) elevation, and must accommodate a heat load of 4 kW.



For each additional 1000 meters (3280.8 feet) above sea level, increase the airflow (CFM) value by 15%. If an extraction duct is not used, the operating temperature range is restricted to 10 to 25°C (50 to 77°F) at a maximum altitude of 2000 meters (6561.7 feet).

Projector power connections

The projector requires two, 30A maximum rated, certified wall circuit breakers (one for each Main Input). The wall circuit breakers must be part of the building and easily accessible.

The projector must be connected to power using hard-wired connections. The projector light source requires the permanent AC connections to operate. A qualified electrician is required to connect the projector to AC power.

There is also an available connector for an uninterruptible power supply (UPS) to provide backup power for the projector electronics only. The UPS connection requires a 20A maximum rated circuit breaker.

Chiller power connection

The chiller is connected to AC power through a power supply terminal located at the front of the chiller unit.

A qualified electrician is required to connect the chiller unit to AC power. For detailed information, refer to the documentation provided by the chiller manufacturer. For electrical rating information, refer to the license label on the chiller.

Related information

- Connecting the chiller power cable (on page 40)*
- Connecting to an uninterruptible power supply (on page 33)*
- Connecting to power (on page 29)*

Power specifications

Learn the power requirements for the projector.

CP4445-RGB

Item	Main input A	Main input B	UPS input
Voltage range	200-240 VAC, single phase	200-240 VAC, single phase	100-240 VAC, single phase
Maximum current	10 A	8 A	5 A
Line frequency	50/60 Hz	50/60 Hz	50/60 Hz

CP4455-RGB

Item	Main input A	Main input B	UPS input
Voltage range	200-240 VAC, single phase	200-240 VAC, single phase	100-240 VAC, single phase
Maximum current	13 A	8 A	5 A
Line frequency	50/60 Hz	50/60 Hz	50/60 Hz

Projector components

Learn about the components of the projector.

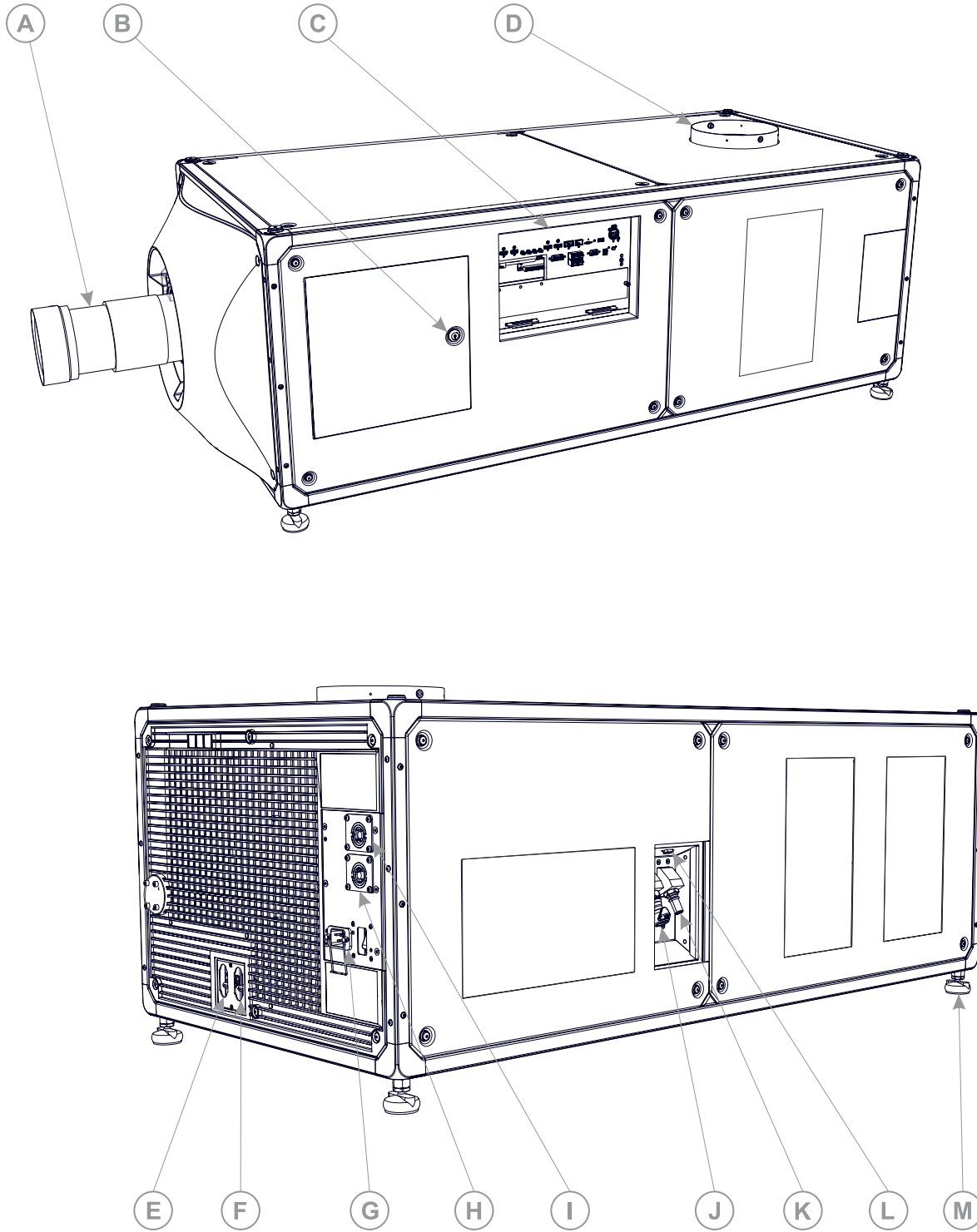

ID	Component
A	Projector lens
B	Service access door
C	Communications panel—External devices are connected here.
D	Exhaust duct connection
E	AC input circuit breaker A
F	AC input circuit breaker B
G	UPS input
H	AC receptacle B
I	AC receptacle A
J	Liquid cooling supply line connection
K	Liquid cooling return line connection
L	Communication connection for the chiller
M	Adjustable feet—Turn the adjustable feet to increase or decrease the projector height.

Chiller components

Learn about the components of the chiller, which is used with CP4445-RGB and CP4455-RGB projectors.

Teyu 6200 chiller components

Identify the main components of the Teyu 6200 chiller.

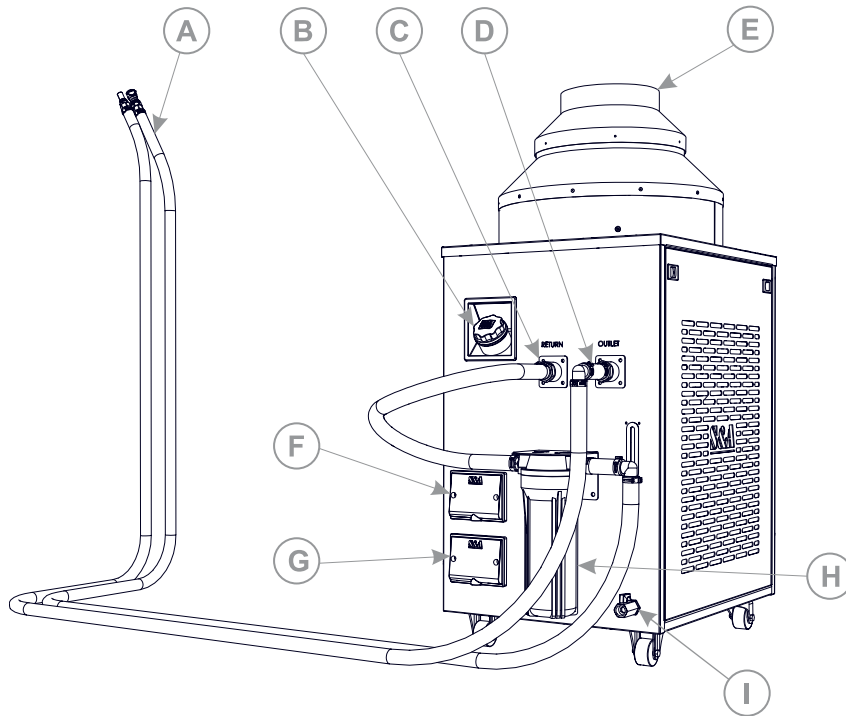

ID	Component
A	Coolant hose
B	Reservoir fill cap
C	Coolant inlet port
D	Coolant outlet port
E	Exhaust vent
F	Communication signal terminal
G	Power supply terminal
H	Chiller coolant filter
I	Coolant drain port

Related information

Setting up the Teyu chiller unit (on page 38)

SMC HRS-040 chiller components

Identify the main components of the SMC HRS-040 chiller.

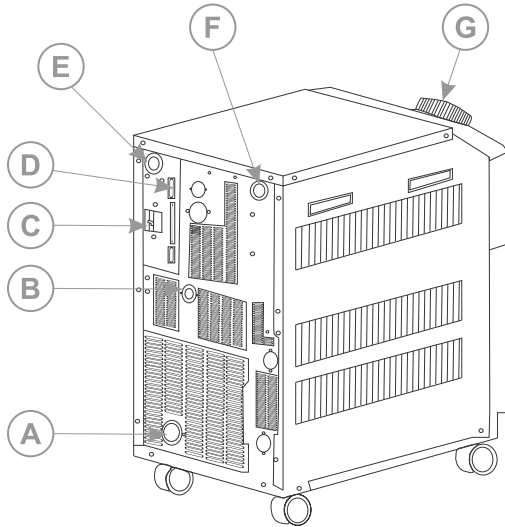

ID	Component
A	Coolant drain port
B	Outlet port
C	Power switch
D	Serial cable port
E	Power cord port
F	Return port
G	Reservoir fill cap

Related information

Setting up the SMC chiller unit (on page 46)

Preparing the installation site

Make sure the installation area is ready for the components.

1. Clear the installation area.
2. Place each component near its installation location.

Lifting and positioning the projector

Safely lift and position the projector in the location where it will be used.



Warning! If not avoided, the following could result in death or serious injury.

- Lift equipment must be used to position the product.
- Do not install or operate the projector in any position that does not meet the stated product specifications for alignment and orientation.

This product must be installed in a landscape orientation, with all four feet supported on a level surface. Do not install or operate the projector in an inverted position. If your site has any installation requirements other than a typical theater projection booth, contact Christie for assistance.



- Before lifting and positioning the projector, refer to the light intensity hazard distances.
- To avoid damage to the lens mount when lifting the projector, do not apply the load across the front of the projector.

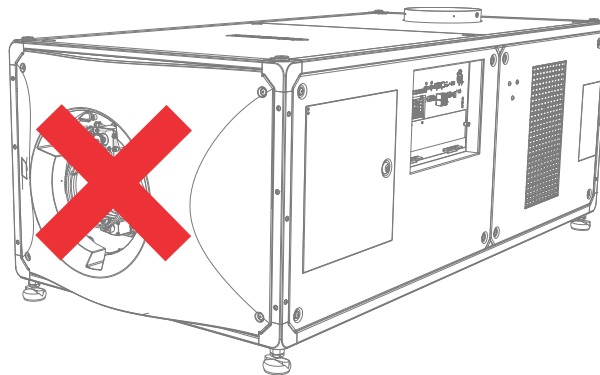

1. Using appropriately rated lift equipment, lift up the projector and move it to the location where it will be used.
2. When lifting, make sure the load is applied only to the structural frame members across two opposite sides of the projector.

The load should never be applied directly to a panel, cover or other non-structural component of the projector. The following illustrations show the structural frame members of the projector:

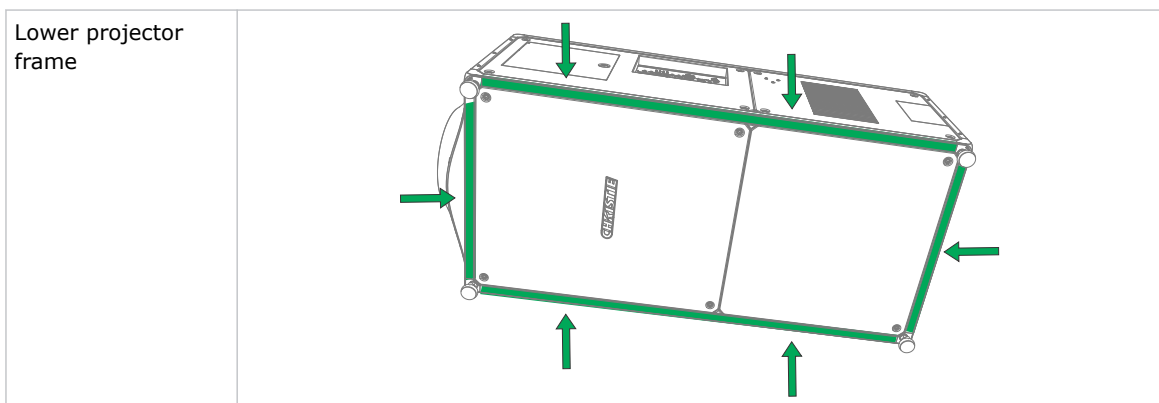

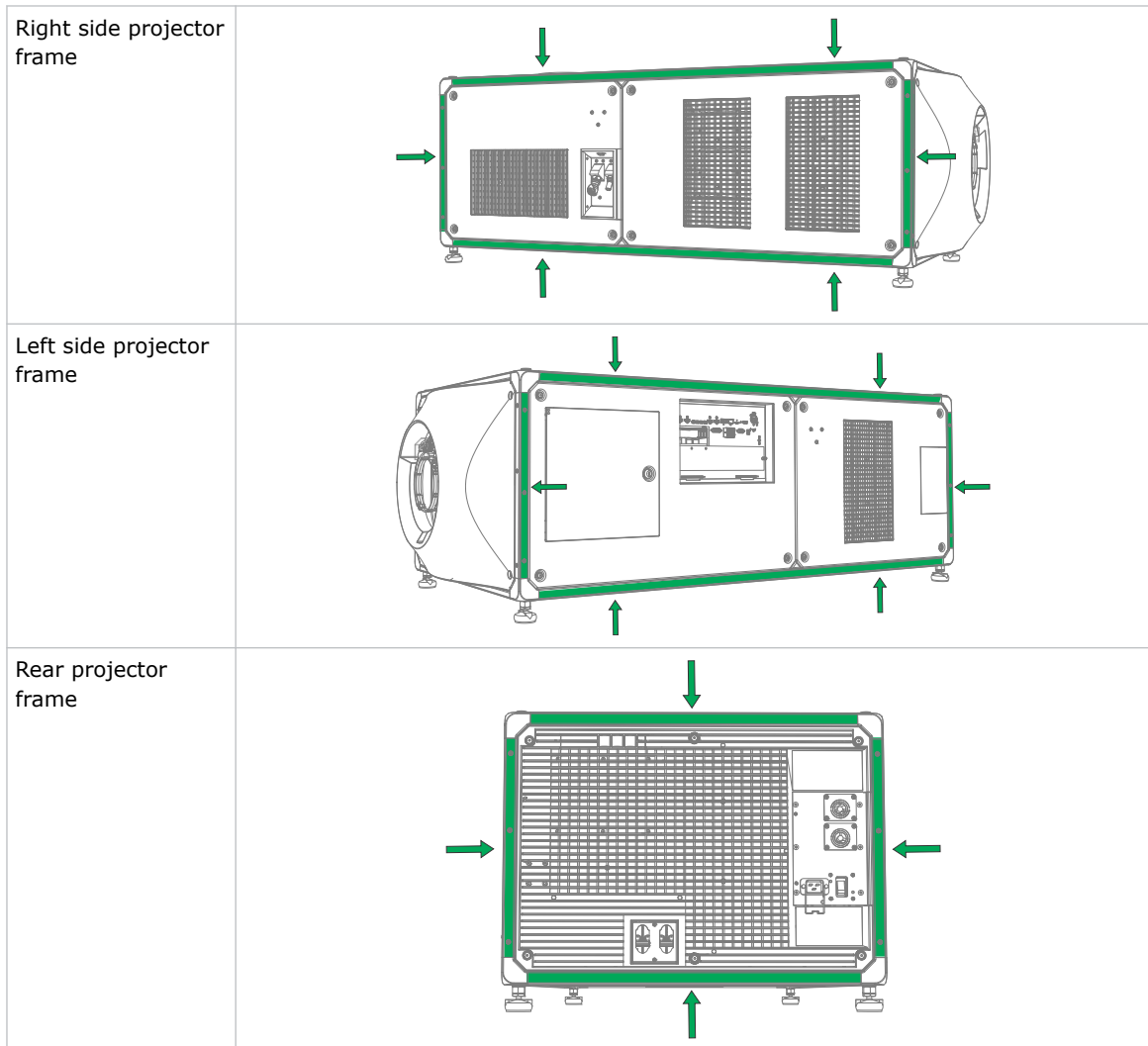

Alternatively, the projector can be lifted using four rigging eyebolts installed into the four anchor points in the top frame of the projector.

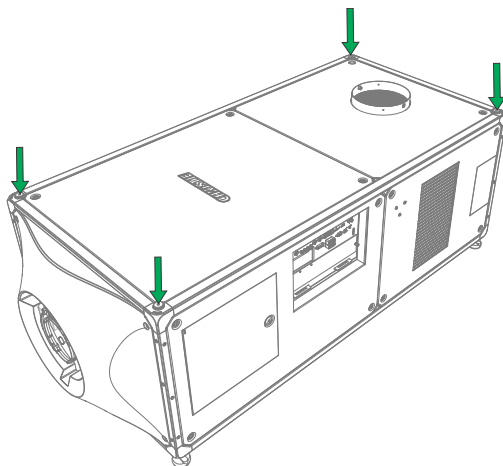

3. If installing the projector with the optional PLF Cinema Pedestal (P/N: 163-126100-XX), follow the instructions provided with that accessory.
4. Position the projector so it is centered and parallel with the theater screen.
If space is limited, aim the projector slightly off-center and use lens offset to center the image on the screen.

Related information

Light intensity hazard distance (on page 8)

Connecting to power

The recommended setup is to provide two hard-wired connections to AC power. When connecting the projector to AC power, follow all electrical codes for your location.



Warning! If not avoided, the following could result in death or serious injury.

- Always connect the ground or earth first to reduce shock hazard.
- FIRE HAZARD! Do not use a power cord, harness, or cable that appears damaged.
- FIRE AND SHOCK HAZARD! Do not attempt operation unless the power cord, power socket, and power plug meet the appropriate local rating standards.
- SHOCK HAZARD! Do not attempt operation if the AC supply is not within the specified voltage and current, as specified on the license label.
- SHOCK HAZARD! A dedicated, protected ground or earth wire must be installed on the product by Christie qualified technicians or electricians before it can be connected to power.
- A certified electrician must be present during installation to make sure the installation meets the local electrical code.



Caution! If not avoided, the following could result in minor or moderate injury.

- Use an appropriately sized strain relief connector with the knockout plate provided, to make sure adequate environmental sealing and to prevent the AC supply cable from accidentally being torn out or rubbing against the knockout plate.



- Two, 30A maximum rated, certified wall circuit breakers are required. They must be part of the building and easily accessible.
- Use a minimum of 12 AWG copper wire, grounding included, for the connection of the main AC supply to the projector's ground lug.
- Either copper or aluminum is acceptable as conductor wiring material to the terminal block.

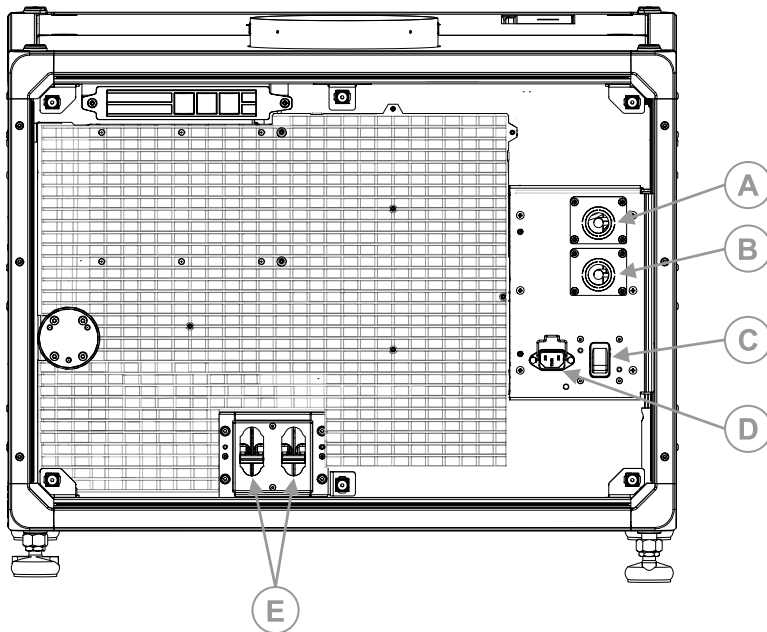

A	Main input A <ul style="list-style-type: none"> • 200-240 VAC, 10 A for CP4445-RGB • 200-240 VAC, 13 A for CP4455-RGB
B	Main input B (200-240 VAC, 8 A) <ul style="list-style-type: none"> • 200-240 VAC, 8 A for CP4445-RGB • 200-240 VAC, 8 A for CP4455-RGB
C	UPS circuit breaker
D	UPS inlet <ul style="list-style-type: none"> • 100-240 VAC, 5 A for CP4445-RGB • 100-240 VAC, 5 A for CP4455-RGB
E	Main input circuit breakers (A and B)

1. Remove the rear cover of the projector by unscrewing the six screws.

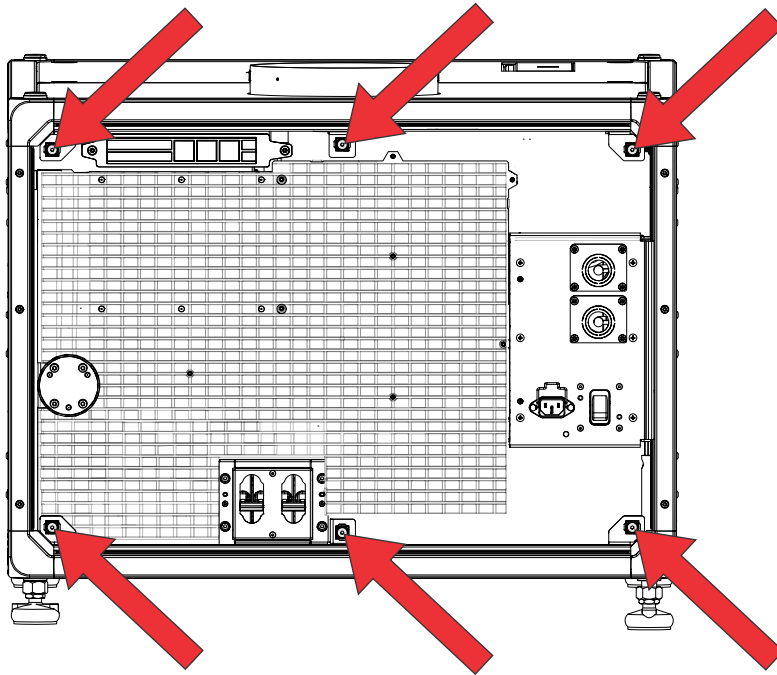

2. On the back right side of the projector, remove the eight screws holding the two AC receptacle knockout plates and then remove the two plates.

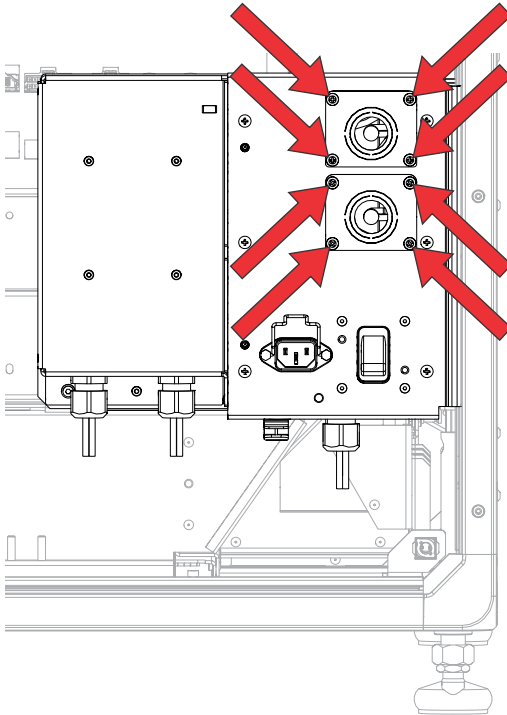

The AC supplies are routed to each terminal block through an appropriate strain relief mounted on the knockout plates.

3. To open the AC input area of the projector, remove the six screws holding the cover and swing the cover downwards to open it.

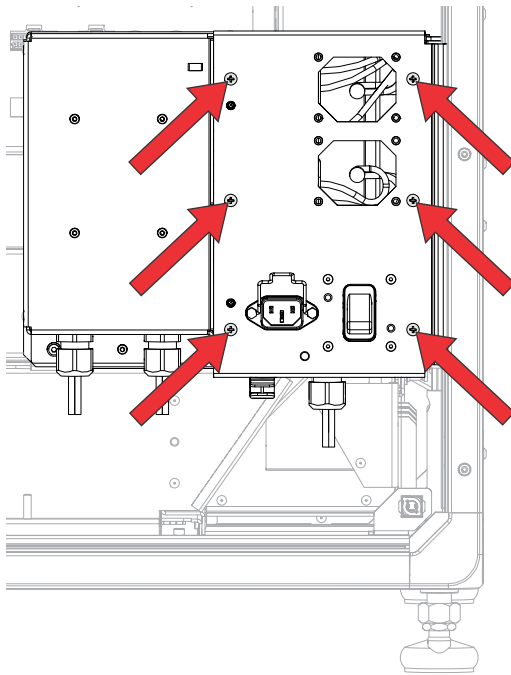

4. Taking the approved line cord for your location, strip the cable jacket on the line cord to expose a 120 mm length of the bundled wires.
5. Cut the Line (black or brown) and Neutral (white or blue) wires to shorten them to a length between 80 to 100 mm.
6. Using a wire stripper, strip the insulation from each individual wire to expose 10 mm of bare wire on the end.
7. Repeat steps 4 to 6 for the second line cord.
8. Pass the wires through the strain reliefs on each knockout plate and through the AC input cover.
9. For each terminal block, fasten the bare end of the wires into the Ground (G), Line (L), and Neutral (N) terminal connectors, starting first with the Ground (green) connection, followed by the Line (black or brown) and Neutral (white or blue) connections.

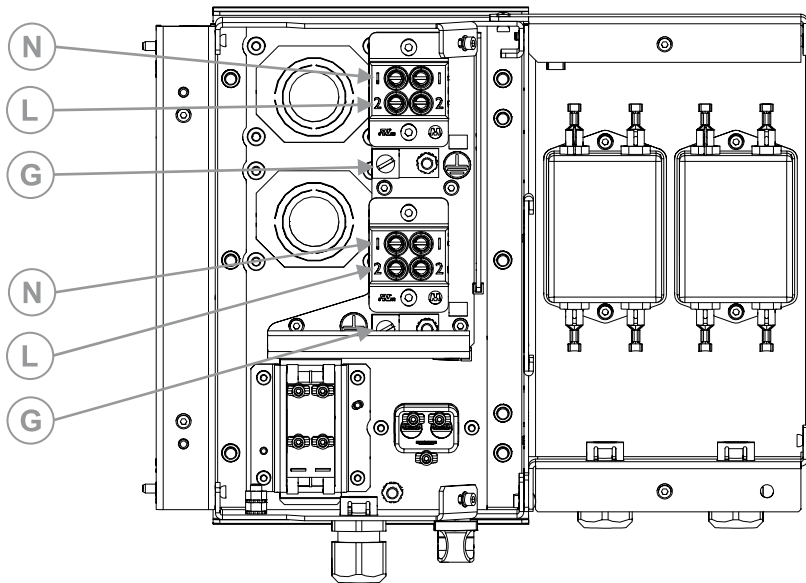

10. Carefully lift the AC input cover into place, making sure the cover does not pinch any of the wires.
11. Re-attach the cover using the six screws.
12. Using the eight screws, re-attach the two knockout plates and make sure the appropriate strain relief is in place for each line cord.
13. Using the six screws, re-install the rear cover of the projector.

Connecting to an uninterruptible power supply

An uninterruptible power supply (UPS) allows the projector head electronics to remain operable during a power failure.



Warning! If not avoided, the following could result in death or serious injury.

- SHOCK HAZARD! The optional UPS power cord must be inserted into an outlet with grounding.

The UPS is connected through the 12V power supply on the projector. The following illustration shows the power supply and connections.

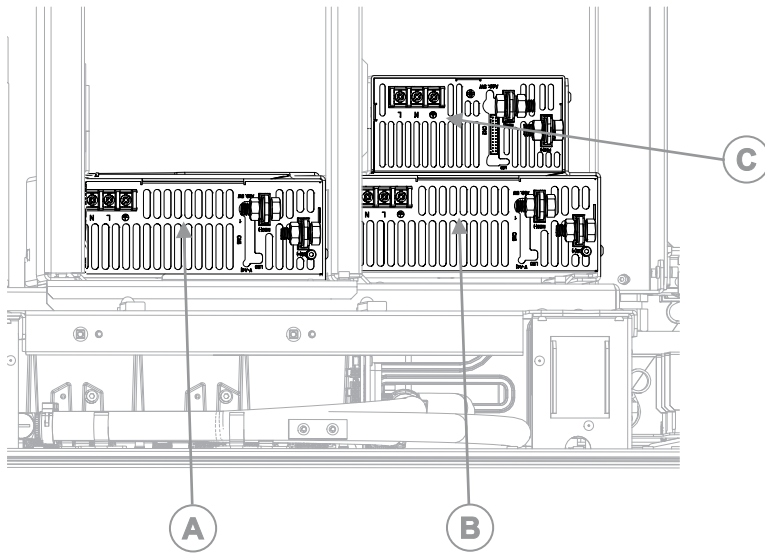

A	48V power supply A
B	48V power supply B
C	12V power supply



Before connecting the UPS device, make sure the projector is disconnected from power.

1. Remove the rear cover of the projector by loosening the six screws.
2. Disconnect the IN-LINE input plug from the 12V power supply.
3. Remove the protective cap from the UPS plug.
4. Connect the IN-LINE connection labeled UPS to the 12V power supply.
5. Place the protective cap from the UPS plug on the IN-LINE input plug.
6. Re-install the rear panel of the projector.
7. Obtain the appropriate line cord for your region, plug the cord into the UPS device, and then plug it into the UPS inlet on the projector.

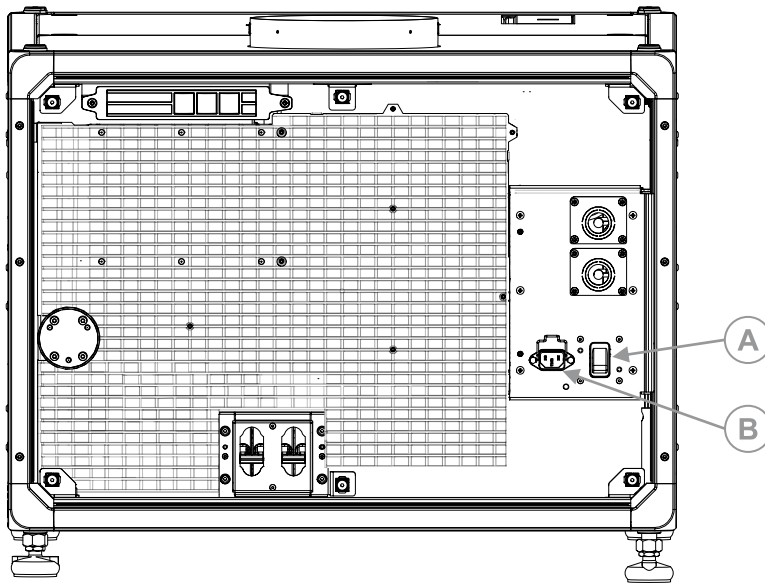

A	UPS circuit breaker
B	UPS inlet (100-240 VAC, 5 A)

Installing the lens

The lens seals the projection head, preventing contaminants from entering the main electronics area.



Notice. If not avoided, the following could result in property damage.

- Do not operate the product without a lens installed.
 - Always use a lens plug when installing or moving the product. This prevents contaminants from entering the product.
 - Do not insert the lens into the product at an angle. This can damage the lens and the optical components inside the product.
 - Always place the lens cap onto the lens when moving the projector to avoid scratching the lens.
 - Remove the lens cap before turning on the product to avoid damaging the lens.
1. Before installing the lens, make sure you turn off the projector and the circuit breaker switches.
 2. Remove the lens caps from the front and rear of the lens.
 - 

Lens caps must be removed or they can melt and damage the lens.
 3. Position the lens so the **UP** label is facing upward.

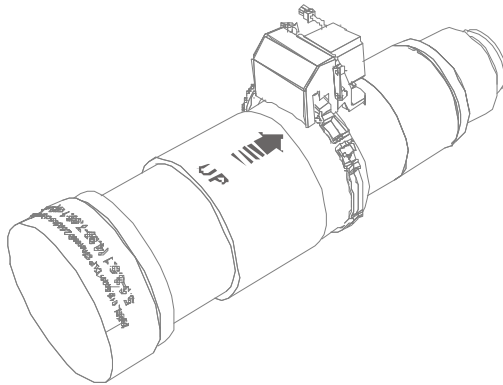

4. Turn the clamp on the lens mount to the open position.

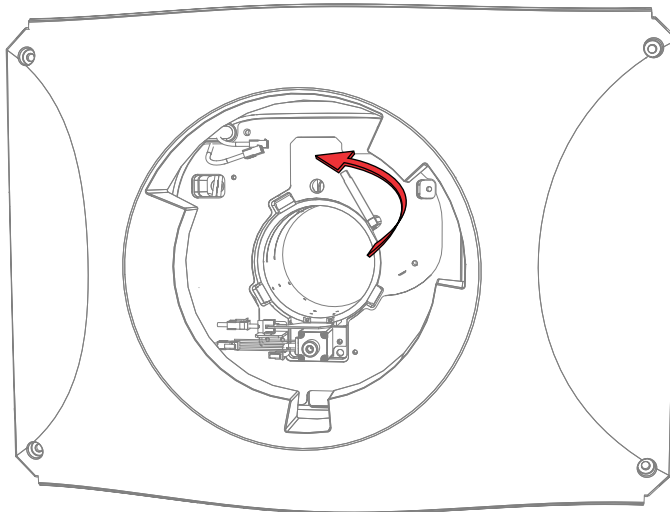

5. Fully insert the lens into the lens mount opening without turning, until it reaches the stop position.
6. Connect the lens zoom motor to the two zoom motor harness connectors.
7. Lock the lens assembly in place by rotating the lens clamp downward.

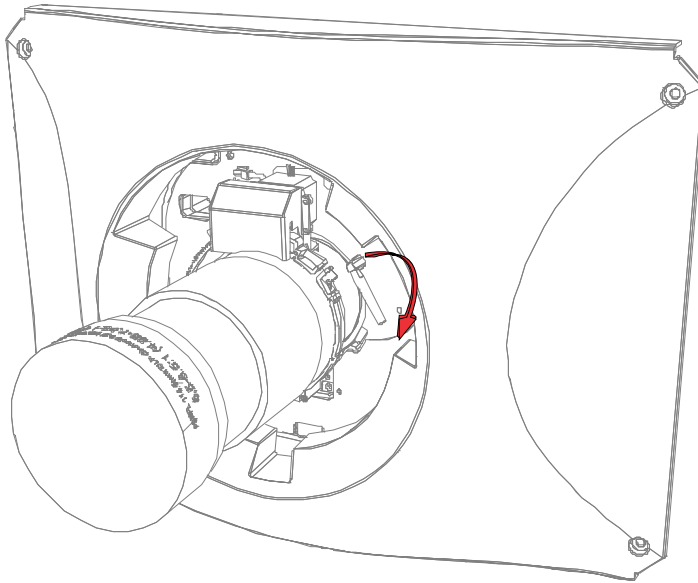

Projector power modes

The CP4445-RGB and CP4455-RGB projectors track laser operation hours for the laser optical subsystems (LOS).

The projector operates with the following power modes:

Mode	Description
Standby	<ul style="list-style-type: none"> • CineLife+ electronics remain on standby with the light engine off. • Fans and LOS are off. • Chiller is off. • Pumps are off. • Integrated Media Block (IMB) is off—IMB automation does not function. • Fire alarm does not function.
Standby (IMB On)	<ul style="list-style-type: none"> • CineLife+ electronics and the IMB are powered on with the light engine off. • Power is available to the optional touch panel and LOS. • Some fans are low speed (depending on projector type). • Pumps are off. • Chiller is off (if applicable). <p>This mode is set from Service Setup > Preferences > IMB.</p>
Projector on	<ul style="list-style-type: none"> • CineLife+ electronics and light engine are on. • LOS is off. • Chiller is on (CP4445-RGB and CP4455-RGB projectors only). • IMB is on.

Mode	Description
Light source on	<ul style="list-style-type: none"> • CineLife+ electronics and light engine are on. • LOS is on. • Fans run at full speed. • Chiller is on (CP4445-RGB and CP4455-RGB projectors only). • IMB is on.

Using the Remote user interface (UI)

Use the remote user interface (UI) to access projector functionality.

The Remote user interface (UI) is available as an accessory.

1. Log into the Remote UI.
The default IP address is 192.168.206.110.
2. From the Remote UI default page, to access the main projector user interface, select the **Projector Control** tab.
3. To upload and download files from the projector, use the **File Menu**.
Examples of items that can be uploaded include:
 - Projector upgrade packages
 - Backup packages to restore from
 - Rental files to license the projector for Rental mode
 - Test patterns (PNG files only)
 - Gamma files
 Examples of items that can be downloaded include:
 - Projector backup files
 - Projector certificates (required for content decryption)
 - Interrogator files (for support and troubleshooting)
4. If the projector has a GDC IMB SR-1000 installed and configured, access the GDC IMB Web UI by using the **Media Block** tab.

Setting up the chiller unit

For detailed information on setting up the chiller, refer to the documentation provided by the manufacturer of the chiller unit.

Once the chiller is connected to AC and the chiller communication cable is connected to the projector, the projector controls the chiller automatically to maintain the required coolant temperature.

Setting up the Teyu chiller unit

Learn how to complete the set up of the Teyu chiller unit.

Connecting the chiller communication cable

The chiller communication cable is connected through a signal terminal located at the front of the chiller unit. The connection allows communication between the projector and the chiller.

The chiller communication cable includes an RS-485 connector, attached cable with rubber grommet, and three terminal connectors.



The installation of the chiller communication cable must be performed by a Christie qualified technician.

1. Remove the cover for the signal terminal by unscrewing the two cover screws.

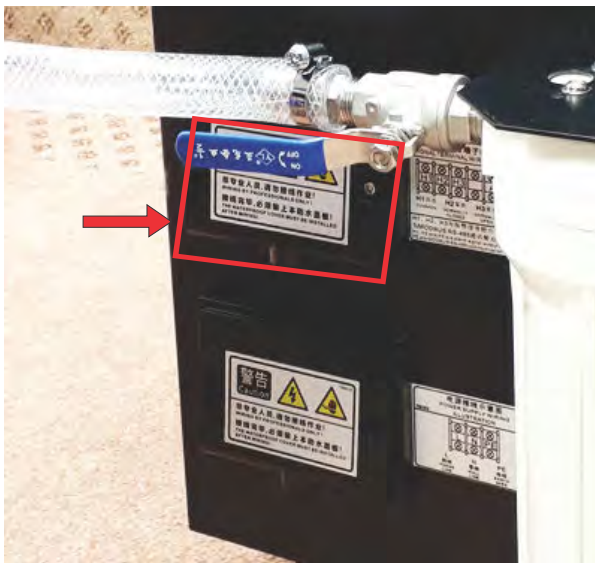

2. Connect the A, B, and PE harness connectors to the corresponding terminals.

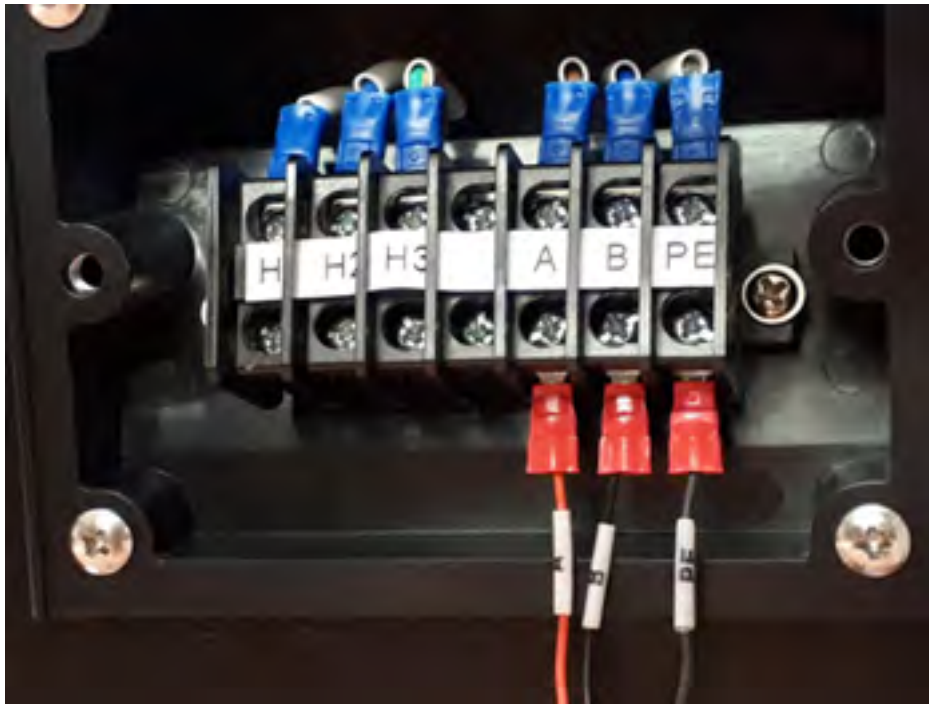

Do not use the H1, H2, or H3 terminals.

3. Tighten the screws at each terminal.
4. Re-attach the signal terminal cover using the two cover screws.
To avoid pinching the cable, make sure the cable and rubber grommet are placed inside the cover cutout.
5. Connect the RS-485 connector to a serial cable and into the RS-485 communication port on the projector.

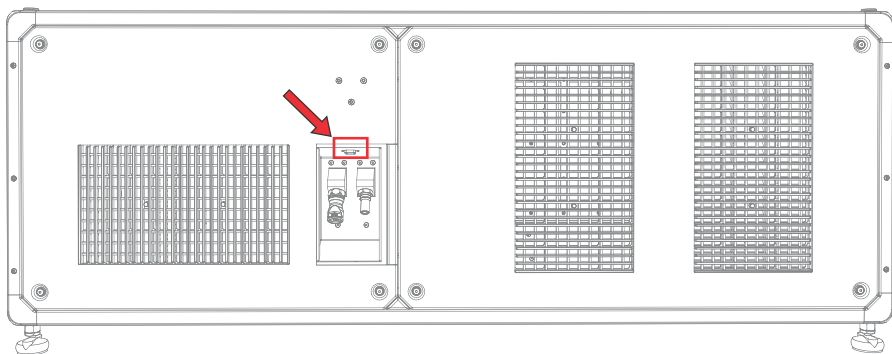

Connecting the chiller power cable

The chiller is connected to AC power through a power supply terminal located at the front of the chiller unit.

The wires of the supplied power cord are connected to the three terminals in the power supply terminal.



- A qualified electrician is required to connect the chiller unit to AC power. For detailed information, refer to the documentation provided by the chiller manufacturer.
- For electrical rating information, refer to the license label on the chiller. Additional information is available in the chiller's product documentation.

1. Remove the cover for the power supply terminal by unscrewing the two cover screws.

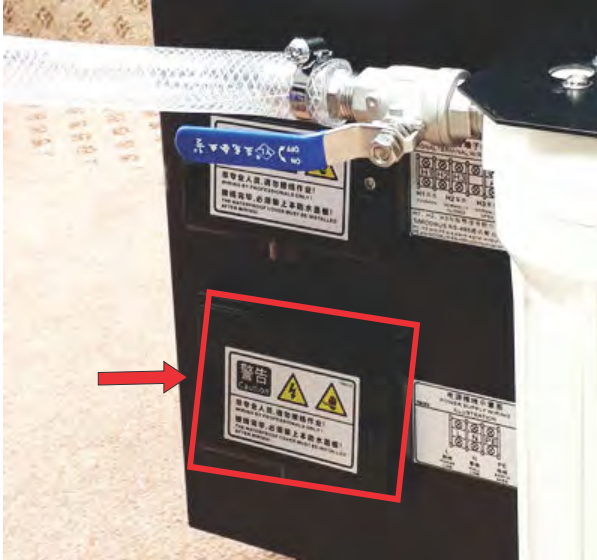

2. Make sure the rubber grommet is installed on the cable at the connector end. The grommet provides strain relief protection for the power cable.

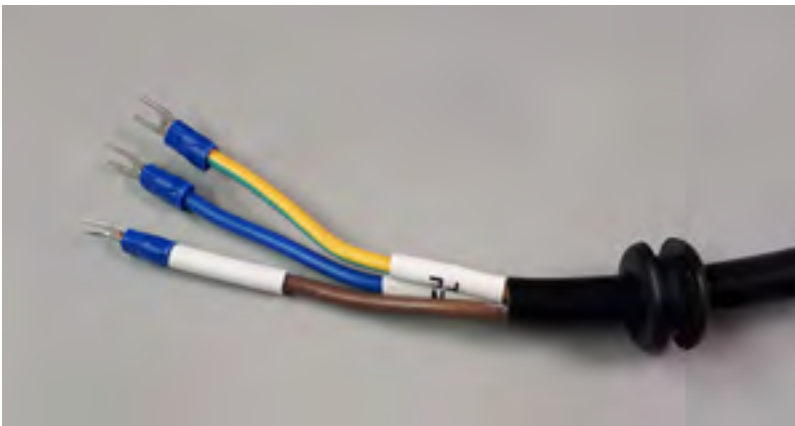

3. Connect the L, N, and PE harness connectors to the corresponding terminals.



4. Tighten the screws at each terminal.
5. Route the power cable through the slot provided on the terminal block cover.
To avoid pinching the power cable, make sure the cable and rubber grommet are placed inside the cover cutout.



6. Re-attach the terminal block cover using the two cover screws.
7. Plug the power cable into an appropriately rated AC power outlet.

Connecting the coolant lines

The required coolant lines and hose accessories are available in the Christie Teyu chiller setup kit plumbing (P/N: 163-149105-XX).



- Make sure the coolant lines connecting the projector and chiller are installed at floor level. Installing the coolant lines at a higher elevation, such as across a ceiling, can result in a backflow through the lines and an overflow of the chiller reservoir. If your site requires installation on different levels, contact Christie Technical Support for further information.
- In dual projector installations, verify the chiller communication cables are connected correctly between each projector-chiller pair and that the cables are not cross-connected relative to the coolant lines.

1. Position the chiller.
2. Install the required hose accessories on the chiller inlet and outlet ports, including:
 - Inlet hose from the chiller inlet port to the chiller filter
 - Hose and elbow fitting at the filter inlet
 - Outlet hose and elbow fitting at the chiller outlet port

The inlet filter and hose barbs required for the chiller are pre-installed.



3. Connect the coolant lines between the chiller and the projector.
To avoid cross-connections, the supply and return lines have specific male and female quick connectors that connect into the projector.
 - a) Connect the open end of the Chiller Outlet hose to the chiller outlet port and tighten the required worm gear clamp.
 - b) Attach the Chiller Outlet quick connector (male) to the projector inlet port (female).
 - c) Connect the open end of the Chiller Inlet hose to the chiller inlet port (at the filter) and tighten the required worm gear clamp.
 - d) Attach the Chiller Inlet quick connector (female) to the projector outlet port (male).

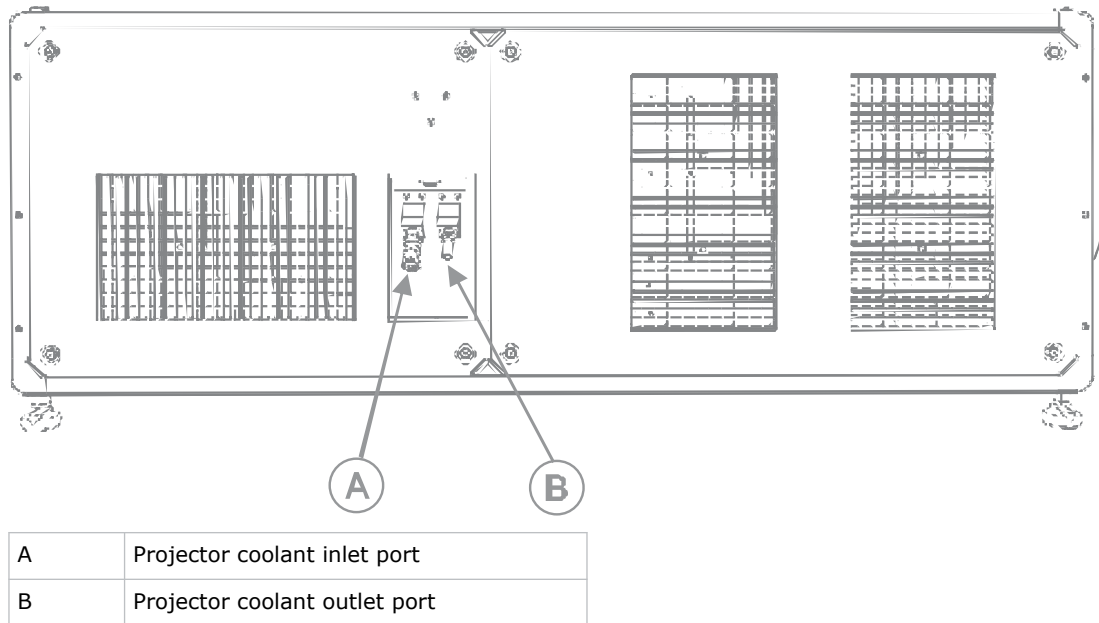

For detailed information on connecting the coolant lines and hose accessories, refer to the *Installing the Teyu Chiller Instruction Sheet (P/N: 020-103145-XX)*.

Installing the chiller duct

Installing a chiller duct and exhaust conduit allows warm air generated by the chiller to be removed from the projection room.

1. Attach the duct over the exhaust fan on the top of the chiller unit.
The duct is available in the Christie Chiller Air Ducts Setup kit (P/N: 163-150107-XX).
For detailed information on connecting the chiller duct, refer to the *Installing the Teyu Chiller Instruction Sheet (P/N: 020-103145-XX)*.
2. If required, a reducer duct is also provided in the kit and can be installed over the base duct to accommodate smaller diameter exhaust conduits.
3. Once installed, connect the duct into the exhaust conduit to vent the heated air outside of the projection room.

Filling and starting the chiller

Make sure the coolant lines are connected to the projector and all connections are tightened.

1. Open the chiller reservoir fill cap.



2. Using the provided funnel, fill the chiller reservoir with the required coolant (Propylene Glycol P/N: 163-130105-XX).
3. Start the chiller and allow the coolant lines to fill.
4. Check the coolant level in the reservoir and top up the coolant as required.



For detailed information on operating and maintaining the chiller, refer to the product documentation provided by the chiller manufacturer.

5. Verify coolant is flowing in the correct direction and no leaks are in the system.
6. Make sure the chiller communication cable between the projector and the chiller is connected correctly.



To avoid thermal shutdown conditions in dual projector installations, Christie recommends running each chiller and its attached projector separately, with light on, to confirm chiller communication cables are not cross-connected relative to the coolant lines.

Related information

Creating a new laser file for external chiller-based projectors (on page 76)

Setting up the SMC chiller unit

Learn how to complete the set up of the SMC chiller unit.

Connecting the chiller power cable

A certified electrician must install the power cable for the chiller.

1. Have a certified electrician install the power cord by following the instructions in the *SMC Chiller Operation manual*.
2. Apply the alarm code label on the upper panel (as shown in the image below). Alarm code labels can be found in the chiller accessories bag.

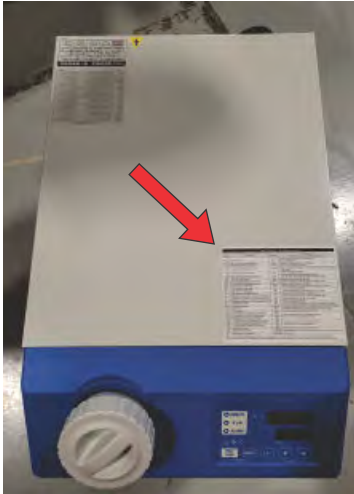

Assembling the chiller connections

Follow these steps to assemble the chiller connections.

1. To prevent rolling, lock the front wheels and place on a flat surface.
2. Remove the plastic cap from the chiller outlet port.



3. Apply three or four rounds of grey sealant tape on the threads for the following components from the assembly kit (P/N: 163-185105-XX):
 - 1/2" PT male-to- 1/2" NPT female adapter (can be found in the chiller accessory kit; C in the image in step 4)
 - 1/2" NPT male-to-female 90° elbow (B in the image in step 4)
 - Male (plug) quick-disconnect (A in the image in step 4)

Make sure to leave the first thread at the end of the components free of tape.

4. Assemble the quick disconnect (A in the image below), NPT elbow (B in the image below), and PT-NPT adapter (C in the image below) together, using a pair of adjustable wrenches to tighten.



5. Install the sub-assembly to the chiller outlet, making sure the assembly is facing down.



6. Remove the plastic cap from the chiller return port.



7. Apply three to four rounds of grey sealant tape to the following components:

- ½" NPT male-to-female 90° elbow (B in the image in step 9)
- Female (socket) quick disconnect (A in the image in step 9)
- ½" NPT-to-½" PT adapter (can be found in the particle filter packaging; C in the image in step 9)

Make sure to leave the first few threads at the end of the components free of tape.

8. Install the female (socket) quick-disconnect (A in the image in step 9) to the ½" NPT male-to-female elbow (B in the image in step 9).

Use an adjustable wrench to tighten them.

9. Install components (A+B and C in the image below) onto the particle filter housing (D in the image below).

- a) Install the sub-assembly from step 8 (A+B in the image below) to the 125 mm particle filter housing inlet (next to the red button, turning it so it is facing down).

Do not cross thread the particle filter housing and hand tighten the assembly.

- b) Install the NPT side of the ½" NPT-to-½" PT adapter (C in the image below) to the other side of the particle filter.



Make sure to note the PT and NPT marking on the part and hand tighten the assembly.



10. Unscrew the particle filter bottom housing.
11. Install a new 5 um particle filter (P/N: 012-104287-XX).
12. Re-install the particle filter bottom housing.
13. Install the particle filter housing assembly to the chiller return port, using adjustable wrenches to tighten the assembly to the chiller.

See the image below for the recommended orientation.



14. Remove the chiller reservoir lid.
15. Insert a tank particle filter (P/N:012-104286-XX).
16. Re-install the chiller reservoir lid.

Assembling the hose

Follow these steps to assemble the hose.

1. Apply three or four rounds of sealant tape to the following items from the chiller connection kit (P/N: 163-187107-XX):
 - Two SAE 8 female x 1/2" NPT male straight adapters (A in image below)
 - Female (socket) quick disconnect (B in image below)
 - Male (plug) quick disconnect (C in image below)

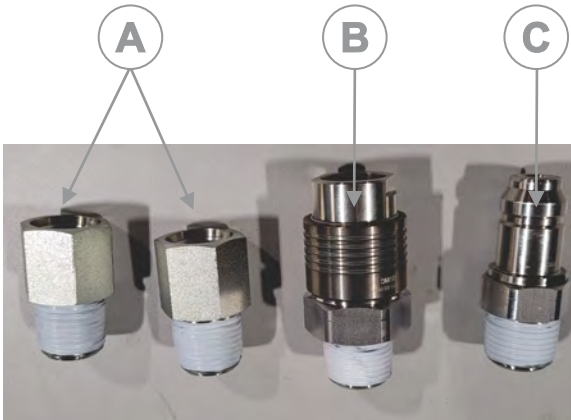

2. Install each SAE-to-NPT adapter to one end of each of the hoses.
3. Select one hose and screw on the LQ6 male quick disconnect (see image below) to the end with the SAE 8 female x 1/2" NPT male straight adapter.
Do not apply the thread sealant tape to the LQ6 male quick disconnect.



4. Install the female (socket) quick disconnect (see image below) to the opposite end.



5. Use a pair of adjustable wrenches to tighten both ends.
6. Select the second hose and install the LQ6 female quick disconnect (see image below) to the hose end with the SAE 8 female x 1/2" NPT male straight adapter.
Do not apply the thread sealant tape to the LQ6 female quick disconnect.



7. Install the male (plug) quick disconnect (see image below) to the opposite end.



8. Use a pair of adjustable wrenches to tighten both ends.
9. Connect the hose kit to the outlet and return port of the chiller.

Starting the chiller

Follow these steps to start the chiller.

1. To run the system for the first time, connect the female LQ6 to the male LQ6. These quick disconnects are normally connected to the projector.



2. To fill the chiller with coolant at the tank inlet, follow the instructions included in the *Maintaining Chiller Coolant Levels Instruction Sheet (P/N: 020-103450-XX)*.

Setting up the chiller communication

For a new SMC chiller, the menu settings are not set to the values needed to use a serial cable to control the chiller. Once the menu options are set, they are saved on the chiller, even if the chiller is unplugged.

The chiller can be controlled with two modes:

- Set the chiller conditions using the control panel on the front of the chiller.
- Set the chiller conditions remotely using a serial cable.

When the LED indicator beside the word *REMOTE* is on, the chiller is set to be controlled remotely by a serial cable.



Connecting the SMC serial cable

The SMC chiller cable needs an adapter to plug into the back of the chiller.

1. Plug the adapter (P/N:001-115197-XX) into the back of the chiller.
2. Plug the chiller cable (P/N: 001-112405-XX) into the adapter on the back of the chiller.
3. Plug the other end of the chiller cable into the projector.

If the projector is turned on when you connect the cable, the projector display shows a disconnected error message. When you navigate through the prompts to get to the communication, the message disappears.

Navigating to the Communications menu

Follow these steps to navigate to the Communications menu.

The initial display shows the coolant temperature and setpoint.

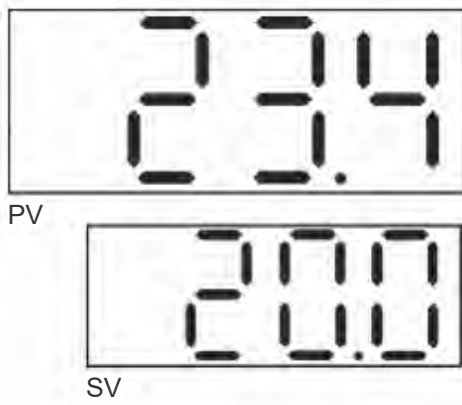

1. From the coolant temperature and setpoint on the display, select and hold the **Menu** button, releasing the button when the chiller beeps (after approximately two seconds).
2. Select and hold the **Menu** button three more times to navigate through the menus to get to the Communication menu.

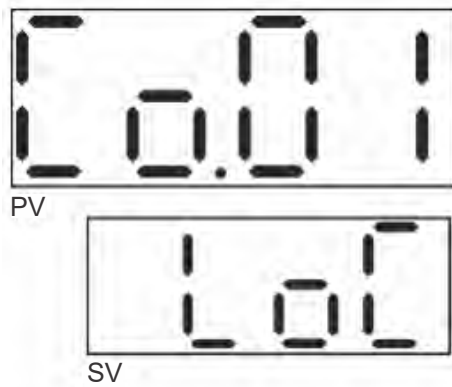

Controlling the chiller

You can control the chiller from either the projector or the control panel. You only need to control the chiller from the control panel if the remote LED indicator is on.

1. Control the chiller from the control panel:
 - a) *Navigate to the Communications menu* (on page 52).
 - b) If the lower line does not display **LoC**, select the **Up/Down** buttons until it is displayed.
 - c) When **LoC** is displayed, select the **Menu** button to use the chiller.
The LED indicator labeled REMOTE is off while in local mode.
2. Control the chiller from the projector:
 - a) *Navigate to the Communications menu* (on page 52).
 - b) Verify the lower line reads **SEr** and if it does not, select the **Up/Down** buttons until it does.
 - c) When the second line reads **SEr**, select the **SEL** button to display the Communication menu 2.
 - d) Use the **Up/Down** buttons to make sure the second line selects the MODBUS serial protocol.

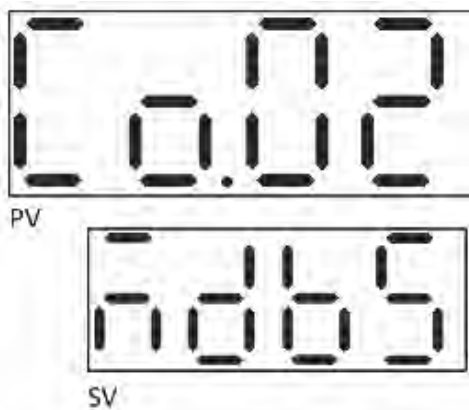

- e) Once the MODBUS serial protocol is selected, select the **SEL** button to display Communication menu 3.
- f) Use the **Up/Down** buttons to select **485** for the RS485 serial protocol.
- g) Select the **SEL** button to display the Communication menu 4.

- h) Use the **Up/Down** buttons to select **on**.
- i) Select the **SEL** button to display the Communication menu 5.
- j) Make sure the second line reads 1.
- k) Select the **SEL** button to display the Communication menu 6.
- l) Use the **Up/Down** buttons to select **9.6** to set the Communication channel to 9600 Baud.
- m) To save the settings and return to normal operation, select the **Menu** button.

Setting the chiller setpoint

The chiller setpoint represents the temperature of the coolant supplied to projector.

The default chiller setpoint temperature is 24°C (75.2°F). The default setting addresses many typical projection booth conditions, ensuring maximum projector brightness and operating efficiency.

If room temperatures or relative humidity are allowed to rise, the maximum power setting available for the lasers is reduced and brightness is decreased as a result.



The projector is equipped with sensors monitoring ambient temperature and humidity. When selecting the chiller setpoint, use the actual temperature and relative humidity of the projection booth expected during operating conditions. Selecting a setpoint not reflecting actual show environment conditions may result in a sub-optimal projection image.

1. Use the reference chart below to determine the coolant temperature required for your site.

Chiller Setpoint Temperature

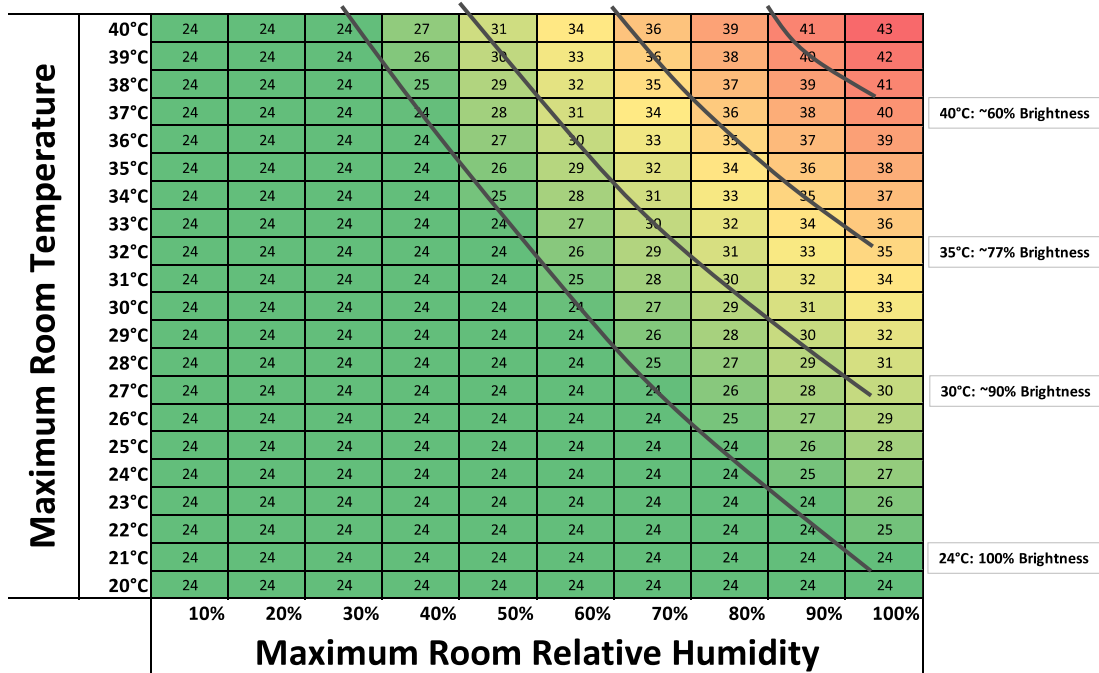

2. On the Y axis of the chart, find the **Maximum Room Temperature** expected in the projection booth.
3. On the X axis of the chart, find the **Maximum Room Relative Humidity**.

4. To identify the correct chiller setpoint temperature, find the intersection of the two rows. Choosing a chiller setpoint temperature falling outside the green area means the projector brightness is reduced.
5. On the projector touch panel, select **Laser Settings** > **Laser Power/LiteLOC Setup**, and follow the steps for creating a new laser file, including setting the chiller setpoint value.

Maintaining the chiller

For detailed information on maintaining the chiller equipment, refer to the product documentation provided by the chiller manufacturer.

To identify any leaks or problems, perform regular visual inspections of the chiller equipment and connections to the projector.

Follow the recommended coolant replacement and preventative maintenance schedules. For more information, contact Christie technical support.



Dispose of coolant in accordance with local regulations.

System operation for CP4445-RGB and CP4455-RGB projectors only

Understand the correct sequence for powering up and operating CP4445-RGB and CP4455-RGB systems.

The connected chiller must always be turned on first and turned off only after the projector is turned off.

The system is ready to operate when the following steps are completed:

1. The connected chiller unit is powered on.
2. The projector's main power switches are on.
3. Communication between the projector and the connected chiller is confirmed and coolant temperatures are correctly maintained.

If a thermal shutdown occurs in a dual projector installation, verify the chiller communication cables are connected correctly between each projector-chiller pair. This makes sure no cross-connection exists relative to the coolant lines.

Related information

Setting up the Teyu chiller unit (on page 38)

Setting up the SMC chiller unit (on page 46)

Turning on or off the projector

Turn on the projector to display content or turn off the projector to conserve energy or service the projector.

1. To operate the projector, make sure the circuit breakers are in the ON position.

If servicing the projector or removing the protective covers, make sure the MAIN and UPS circuit breakers are in the OFF position.

2. In the right toolbar, select and hold **Power**. 

If the light source is on when turning off the projector, the light source automatically enters a three-minute cool-down period.

Logging into the projector

Log into the projector to access projector menus.

1. Select **Login**.
2. In the User list, select a username.
3. Enter your password.
4. Select **Login**.

Turning on or off the light source

Turn on the light source to display content or view test patterns. Turn off the light to extend the life of the light source.

- To turn on or off the light source, in the right toolbar, select and hold **Light**. 

Activating marriage

After selecting the Integrated Media Block (IMB) type, you must install the IMB and complete marriage to display secure content and to comply with the Digital Cinema Initiatives (DCI) specification. You cannot complete marriage remotely.

For more information on marriage, refer to *CineLife+ User Guide (P/N: 020-103073-XX)*.

You cannot complete marriage remotely because you must select the **Marriage** button on the input panel during the marriage process.

1. In the left navigation menu, select **Service Setup > Marriage Setup**.
2. Select **Start** and complete the Marriage Setup wizard.
3. Select **Finish**.
4. Verify the marriage ring is installed correctly and an anti-tamper alarm does not appear on the touch panel.

Disposing of the product packaging

Once the product has been installed and set up, Christie recommends reusing or recycling the product packaging according to your local regulations.

Completing the installation checklist

Complete the provided installation checklist (P/N: 020-103137-XX) and return it to Christie.

Video Input panel

The Video Input panel, located on the projector side input panel (operator side), has a variety of ports that can supply alternative video content to the projector.

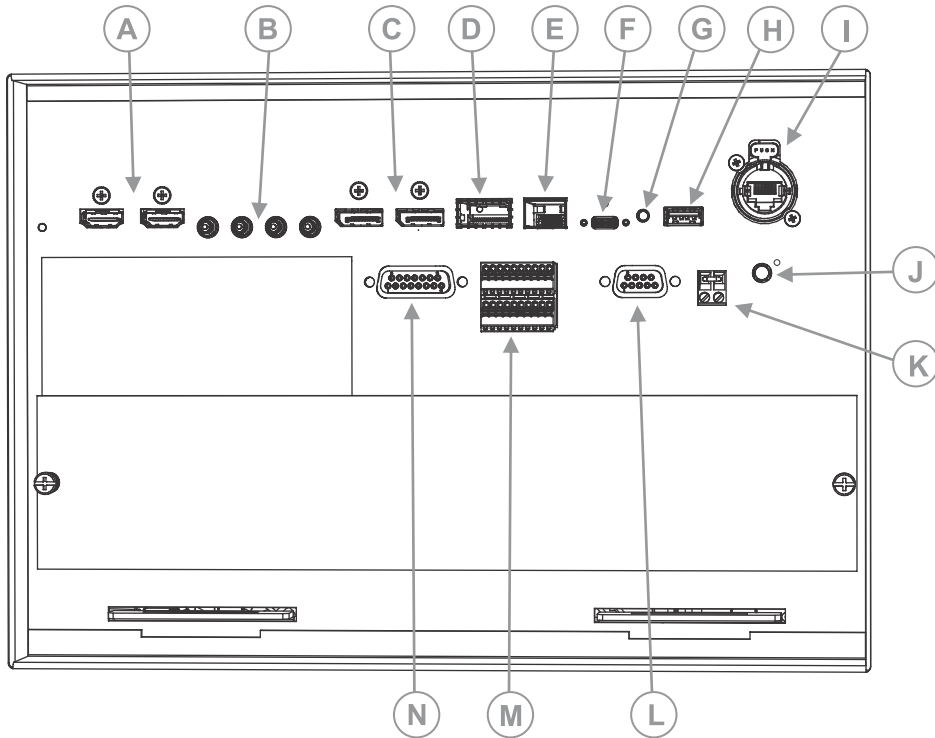

ID	Port	Description
A	HDMI input 1 and HDMI input 2	Type A connector Accepts digital video data from HDMI v2.0 input supporting EDID 1.3 with HDCP v1.4 and 2.2 support.
B	SDI input 1, SDI input 2, SDI input 3, and SDI input 4	75 ohm Micro-BNC Connector Multi-Rate SDI in accordance with SMPTE ST 259 (270 Mb/s), ST 292-1 (1.5 Gb/s), ST 424 (3.0 Gb/s), ST 2081-1 (6 Gb/s) and ST 2082-1 (12 Gb/s)
C	DisplayPort (DP1 and DP2)	Accepts digital video data from DisplayPort 1.2 input supporting EDID 1.3 with HDCP 1.3 support.
D	Christie Link port	Not used.
E	Software-Defined Video over Ethernet (SDVoE) port	Not used.
F	USB-C port	Connects the projector touch panel.

ID	Port	Description
G	Recessed button	Select the button to transition the projector from Standby mode to Power ON mode.
H	USB port	Connects to external memory device for import and export of projector software, configuration files, and status information.
I	Management port	Connects to the local network and can send CineLife+ serial commands and used for Remote UI access.
J	Marriage button	Used during the Integrated Media Block (IMB) marriage setup process. <ul style="list-style-type: none"> • Select and hold the button for 5 seconds to display the IP address and status information. • Select and hold the button for 30 seconds to reset the IP address to the default address. The marriage status LED indicator is located to the right of the Marriage button. In full power mode, a green LED indicates the projector is properly married and encrypted content can be displayed. A red LED indicates marriage is broken and encrypted content cannot be displayed.
K	Fire alarm connection	Connects to the Theater Fire Management system for automatic shut down in emergency situations.
L	RS232 communication port	Not used.
M	GPIO port	Connects the projector to external automation or automation devices.
N	3D sync connector	Connects the projector to 3D devices.

HDMI video source

For the projector to accept digital video data from HDMI sources, plug the HDMI source directly into the Video Input panel.

The input configurations listed below are supported.

Input configuration	Description
Single-input	Accepts connection of one HDMI cable. Supports both 2D and 3D frame-packed, top and bottom. In this configuration, the HDMI input supplies the entire video raster.
Dual-input	Enables connection of two HDMI cables in support of 3D LR, where HDMI Input 1 = left eye and HDMI Input 2 = right eye.

HDMI video formats

The following image formats are supported by the two HDMI inputs.



Fractional 1/1.001 frame rates, 1920 x 1080 (HD), and 3840 x 2160 (UHD) formats are also supported.

Single-input 2D 2K and 4K HDMI 2.0 image formats

Each HDMI input supports the following single-input (one cable) 2D 2K and 4K HDMI 2.0 image formats.

	Format	Cables	Frame rate (Hz)	Sampling	Bit-depth
2K	2048x1080	1	24, 25, 30, 50, 60, 120	Y'C _B C _R /RGB/4:4:4 Y'C _B C _R /4:2:2	8/10/12 bpc
4K	4096x2160	1	24, 25, 30	Y'C _B C _R /RGB/4:4:4 Y'C _B C _R /4:2:2	8/10/12 bpc
	4096x2160	1	50, 60	Y'C _B C _R /RGB/4:4:4	8 bpc
	4096x2160	1	50, 60	Y'C _B C _R /4:2:2	8/10/12 bpc

Single-input 2D HD HDMI 2.0 image formats

Each HDMI input supports the following single-input (one cable) 2D HD HDMI 2.0 image formats.

	Format	Cables	Frame rate (Hz)	Sampling	Bit-depth	Notes
HD	1280x720	1	24, 25, 30, 50, 60	Y'C _B C _R /RGB/4:4:4 Y'C _B C _R /4:2:2	8/10/12 bpc	-
	1920x1080i	1	25, 30	Y'C _B C _R /RGB/4:4:4 Y'C _B C _R /4:2:2	8/10/12 bpc	2048x1080 interlaced (50/60 Hz field rate)

Single-input 2D HDMI 2.0 PC image formats

Each HDMI input supports the following single-input 2D HDMI 2.0 PC image formats.

	Format	Cables	Frame rate (Hz)	Sampling	Bit-depth
PC	1280x800	1	60	RGB	8 bpc
	1280x960	1	60	RGB	8 bpc
	1280x1024	1	60	RGB	8 bpc
	1440x900	1	60	RGB	8 bpc
	1680x1050	1	60	RGB	8 bpc
	1600x1200	1	60	RGB	8 bpc
	2048x1200	1	60	RGB	8 bpc

Single-input 3D 2K/HD HDMI 2.0 image formats

Each HDMI input supports the following single-input (one cable) 3D 2K/HD HDMI 2.0 image formats.

	Format	Cables	Frame rate (Hz)	Sampling	Bit-depth	Notes
3D	1280x720	1	50, 60	Y'C _B C _R /RGB/ 4:4:4 Y'C _B C _R /4:2:2	8/10/12 bpc	Frame-packing/ top-and-bottom
	2048x1080	1	24, 25, 30, 50, 60	Y'C _B C _R /RGB/ 4:4:4 Y'C _B C _R /4:2:2	8/10/12 bpc	Frame-packing

Dual-input 3D 2K/4K HDMI 2.0 image formats

The following dual-input 3D 2K/4K HDMI 2.0 image formats are supported, where HDMI Input 1 = left eye and HDMI Input 2 = right eye. Frame rate is expressed per eye in the following table.

	Format	Cables	Frame rate (Hz)	Sampling	Bit-depth
2K	2048x1080	2	24, 25, 30, 50, 60	Y'C _B C _R /RGB/4:4:4 Y'C _B C _R /4:2:2	8/10/12 bpc
4K	4096x2160	2	24, 25, 30	Y'C _B C _R /RGB/4:4:4 Y'C _B C _R /4:2:2	8/10/12 bpc
	4096x2160	2	50, 60	Y'C _B C _R /RGB/4:4:4	8 bpc
	4096x2160	2	50, 60	Y'C _B C _R /4:2:2	8/10/12 bpc

SDI video source

For the projector to accept digital video data from 12G, 6G, 3G, or HD/SD SDI video source, plug the source directly into the Video Input panel.

The input configurations listed below are supported.

Input configuration	Description
Single-link	Accepts connection of 12G, 6G, 3G, and HD/SD SDI input standards.
Dual-link	Accepts connection of dual-link 6G, 3G, and HD SDI input standards.
Quad-link	Accepts connection of quad-link 6G or 3G SDI input standards.

SDI video formats

Each of the SDI inputs supports the following single-Link 2D SD and HD image formats, single-link 2D HD and UHD/4K image formats, dual-link 2D SDI image formats, and quad-link 2D image formats.



Fractional 1/1.001 frame rates, 1920 x 1080 (HD), and 3840 x 2160 (UHD) formats are also supported.

Single-link 2D: SD, 720p and 1080i image formats

The following SDI inputs support the following single-link (one cable) 2D SD, 720p, and 1080i image formats.

	Format	Cables	Frame rate (Hz)	Sampling	Bit-depth	Notes
SD	720x480	1	30	Y'C _B C _R /4:2:2	10 bpc	SD interlaced component at 270 Mb/s (ST 259 level C) interlaced (60 Hz field rate)
	720x576	1	25	Y'C _B C _R /4:2:2	10 bpc	SD interlaced component at 270 Mb/s (ST 259 level C) interlaced (50 Hz field rate)
HD	1280x720	1	24, 25, 30, 50, 60	Y'C _B C _R /4:2:2	10 bpc	HD 720p Y'C _B C _R component at 1.5 Gb/s (ST 292-1)
	1280x720	1	24, 25, 30, 50, 60	Y'C _B C _R /4:4:4(4)	10 bpc	HD 720p Y'C _B C _R /RGB component at 3.0 Gb/s (ST 425-1) level A
2K	2048x1080	1	25, 30	Y'C _B C _R /4:2:2	10 bpc	HD 1080i component at 1.5 Gb/s (ST 292-1) interlaced (50/60 Hz field rate)

Single-link 2D: 2K and 4K HD/UHD

The following SDI inputs support the following single-link (one cable) 2D HD and UHD/4K image formats.

	Format	Cables	Frame rate (Hz)	Sampling	Bit-depth	Notes
2K	2048X1080	1	24, 25, 30	Y'C _B C _R /4:2:2	10 bpc	HD 1080p component at 1.5 Gb/s (ST 292-1)
	2048X1080	1	48, 50, 60	Y'C _B C _R /4:2:2	10 bpc	HD 1080p component at

Format	Cables	Frame rate (Hz)	Sampling	Bit-depth	Notes	
					3.0 Gb/s (ST 425-1) level A	
2048X1080	1	24, 25, 30	Y'C _B C _R /RGB/4:4:4(4)	12 bpc	HD 1080p Y'C _B C _R /RGB component at 3.0 Gb/s (ST 425-1) level A	
2048X1080	1	24, 25, 30	Y'C _B C _R /4:2:2(4)	12 bpc	HD 1080p Y'C _B C _R component at 3.0 Gb/s (ST 425-1) level A	
2048X1080	1	48, 50, 60	Y'C _B C _R /RGB/4:4:4(4)	10 bpc	HD 1080p Y'C _B C _R /RGB component at 6.0 Gb/s (ST 2081-10) mode 2 structure II	
2048X1080	1	48, 50, 60	Y'C _B C _R /RGB/4:4:4	12 bpc	HD 1080p Y'C _B C _R /RGB component at 6.0 Gb/s (ST 2081-10) mode 2 structure III	
4K	4096X2160	1	48, 50, 60	Y'C _B C _R /4:2:2	10 bpc	2160p Y'C _B C _R component at 6.0 Gb/s (ST 2081-10) mode 1 structure 1
	4096X2160	1	24, 25, 30	Y'C _B C _R /RGB/4:4:4(4)	10 bpc	2160p Y'C _B C _R /RGB component at 12.0 Gb/s (ST 2082-10) mode 1 structure 2
	4096X2160	1	24, 25, 30	Y'C _B C _R /RGB/4:4:4	12 bpc	2160p Y'C _B C _R /RGB component at 12.0 Gb/s (ST 2082-10) mode 1 structure 3

Format	Cables	Frame rate (Hz)	Sampling	Bit-depth	Notes
4096X2160	1	24, 25, 30	Y'C _B C _R /4:2:2(4)	12 bpc	2160p Y'C _B C _R component at 12.0 Gb/s (ST 2082-10) mode 1 structure 4

Dual-link 2D: 2K and 4K HD/UHD

The following dual-link (two cable) 2D HD and UHD/4K image formats are supported. Dual-link SDI is a fixed configuration.

- SDI 1 = link 1 of input 1
- SDI 2 = link 2 of input 1
- SDI 3 = link 1 of input 2
- SDI 4 = link 2 of input 2



Fractional 1/1.001 frame rates, 1920x1080, and 3840x2160 (UHD) formats are also supported.

Format	Cables	Frame rate (Hz)	Sampling	Bit-depth	Notes	
2K	2048x1080	2	48, 50, 60	Y'C _B C _R /RGB/4:4:4(4)	10 bpc	Y'C _B C _R /RGB component at dual-link 3 Gb/s (ST 425-3) level A structure II
	2048x1080	2	48, 50, 60	Y'C _B C _R /RGB/4:4:4	12 bpc	Y'C _B C _R /RGB component at dual-link 3 Gb/s (ST 425-3) level A structure III
	2048x1080	2	48, 50, 60	Y'C _B C _R /4:2:2	12 bpc	Y'C _B C _R component at dual-link 3 Gb/s (ST 425-3) level A structure IV
	2048x1080	2	48, 50, 60	Y'C _B C _R /4:2:2:4	12 bpc	Y'C _B C _R component at dual-link 3 Gb/s (ST 425-3) level A structure IV
4K	4096X2160	2	48, 50, 60	Y'C _B C _R /4:2:2	10 bpc	Y'C _B C _R component at

Format	Cables	Frame rate (Hz)	Sampling	Bit-depth	Notes
					dual-link 6 Gb/s (ST 2081-11) mode 1
4096X2160	2	24, 25, 30	Y'C _B C _R /RGB/4:4:4(4)	10 bpc	Y'C _B C _R /RGB component at dual-link 6 Gb/s (ST 2081-11) mode 1
4096X2160	2	24, 25, 30	Y'C _B C _R /RGB/4:4:4	12 bpc	Y'C _B C _R /RGB component at dual-link 6 Gb/s (ST 2081-11) mode 1
4096X2160	2	24, 25, 30	Y'C _B C _R /4:2:2	12 bpc	Y'C _B C _R component at dual-link 6 Gb/s (ST 2081-11) mode 1
4096X2160	2	24, 25, 30	Y'C _B C _R /4:2:2:4	12 bpc	Y'C _B C _R component at dual-link 6 Gb/s (ST 2081-11) mode 1

Quad-link 2D: 4K UHD

The following quad-link (four cable) 2D image formats are supported. The quad-link SDI is a fixed configuration.

- SDI 1 = link 1
- SDI 2 = link 2
- SDI 3 = link 3
- SDI 4 = link 4



Fractional 1/1.001 frame rates and 3840x2160 (UHD) formats are also supported.

Format	Cables	Frame rate (Hz)	Sampling	Bit-depth	Notes
4K	4	24, 25, 30	Y'C _B C _R /RGB/4:4:4(4)	10 bpc	Y'C _B C _R /RGB component at quad-link 3 Gb/s (ST

Format	Cables	Frame rate (Hz)	Sampling	Bit-depth	Notes
					425-5) level A structure 2
4096x2160	4	24, 25, 30	Y'C _B C _R /RGB/4:4:4	12 bpc	Y'C _B C _R /RGB component at quad-link 3 Gb/s (ST 425-5) level A structure 3
4096x2160	4	24, 25, 30	Y'C _B C _R /4:2:2(4)	12 bpc	Y'C _B C _R component at quad-link 3 Gb/s (ST 425-5) level A structure 4
4096x2160	4	24, 25, 30	Y'C _B C _R /4:2:2	12 bpc	Y'C _B C _R component at quad-link 3 Gb/s (ST 425-5) level A structure 4
4096x2160	4	48, 50, 60	Y'C _B C _R /RGB/4:4:4(4)	10 bpc	Y'C _B C _R /RGB component at quad-link 6 Gb/s (ST 2081-12) mode 2 structure III
4096x2160	4	48, 50, 60	Y'C _B C _R /RGB/4:4:4	12 bpc	Y'C _B C _R /RGB component at quad-link 6 Gb/s (ST 2081-12) mode 2 structure III
4096x2160	4	48, 50, 60	Y'C _B C _R /4:2:2:4	12 bpc	Y'C _B C _R component at quad-link 6 Gb/s (ST 2081-12) mode 2 structure IV

DisplayPort video source

For the projector to accept digital video data, plug the DisplayPort source directly into the Video Input panel.

The input configurations listed below are supported.

Input configuration	Description
Single-input	Enables connection of one DisplayPort cable. Supports both 2D and 3D frame sequential transmission format. In this configuration the DisplayPort input supplies the entire video raster.
Dual-input	Enables connection of two DisplayPort cables. Supports both 2D and 3D frame sequential transmission format.

DisplayPort video formats

The following image formats are supported by the DisplayPort inputs.



Frame rates also include fractional 1/1.001 frame rates.

Single-input DisplayPort 1.2 image formats

The following single-input DisplayPort 1.2 image formats are supported on each of the DP 1.2 inputs.

	Format	Cables	Frame rate (Hz)	Sampling	Bit-depth
HD	1280x720	1	24, 25, 30, 50, 60, 120	Y'C _B C _R /RGB/4:4:4	8/10/12bpc
	1920x1080	1	24, 25, 30, 50, 60, 120	Y'C _B C _R /RGB/4:4:4	8/10/12bpc
	2048x1080	1	24, 25, 30, 50, 60, 120	Y'C _B C _R /RGB/4:4:4	8/10/12bpc
4K	3840x2160	1	24, 25, 30, 50, 60	Y'C _B C _R /RGB/4:4:4	8/10bpc
	4096x2160	1	24, 25, 30, 50, 60	Y'C _B C _R /RGB/4:4:4	8/10bpc

Single-input 3D DisplayPort 1.2 image formats

The following single-input 3D DisplayPort image formats are supported in frame sequential transmission format. Frame rate is expressed per eye in the following table.

	Format	Cables	Frame rate (Hz)	Sampling	Bit-depth
HD	1280x720	1	24, 25, 30, 50, 60	Y'C _B C _R /RGB/4:4:4	8/10/12bpc
	1920x1080	1	24, 25, 30, 50, 60	Y'C _B C _R /RGB/4:4:4	8/10/12bpc
	2048x1080	1	24, 25, 30, 50, 60	Y'C _B C _R /RGB/4:4:4	8/10/12bpc
4K	3840x2160	1	24, 25, 30	Y'C _B C _R /RGB/4:4:4	8/10bpc
	4096x2160	1	24, 25, 30	Y'C _B C _R /RGB/4:4:4	8/10bpc

Dual-input 3D DisplayPort 1.2 image formats

The following dual-input 3D DisplayPort 1.2 image formats are supported. Frame rate is expressed per eye in the following table.

	Format	Cables	Frame rate (Hz)	Sampling	Bit-depth
HD	1280x720	2	24, 25, 30, 50, 60	Y'C'B'C'R/RGB/4:4:4	8/10/12bpc
	1920x1080	2	24, 25, 30, 50, 60	Y'C'B'C'R/RGB/4:4:4	8/10/12bpc
	2048x1080	2	24, 25, 30, 50, 60	Y'C'B'C'R/RGB/4:4:4	8/10/12bpc
4K	3840x2160	2	24, 25, 30, 50, 60	Y'C'B'C'R/RGB/4:4:4	8/10bpc
	4096x2160	2	24, 25, 30, 50, 60	Y'C'B'C'R/RGB/4:4:4	8/10bpc

Single-link DisplayPort PC image formats

The following single-link DisplayPort PC image formats are supported.

	Format	Cables	Frame rate (Hz)	Sampling	Bit-depth
PC	1280x800	1	60	RGB	8bpc
	1280x960	1	60	RGB	8bpc
	1280x1024	1	60	RGB	8bpc
	1440x900	1	60	RGB	8bpc
	1680x1050	1	60	RGB	8bpc
	1600x1200	1	60	RGB	8bpc
	1920x1200	1	60	RGB	8bpc

Integrated Media Block (IMB) video source

Connect a compatible device to either the S2 or S4 interface of the projector to send digital video data from an Integrated Media Block (IMB) to the projector.

The IMB input configurations listed below are supported.

Input configuration	Description
IMB S2 or S4	Enables connection of MPEG-2 video formats.
	Enables connection of MPEG-2 MXF interop video formats.
	Enables connection of SMPTE-compatible 2D and 3D video formats

Contact Christie Technical Support to learn which S2 and S4 IMB devices are compatible with Christie projectors.

Series 2 Integrated Media Block (IMB) video formats

S2 Integrated Media Block (IMB) video format support is determined by the IMB make and model. Refer to the associated IMB documentation to understand which of the following video signals are supported.

All MPEG-2 content is converted in the media block to RGB 4:4:4 8-bit before play out.

MPEG image formats

Format	Resolution	Max frame rate 2D	Max frame rate 3D	Min frame rate	Bit-depth
VGA	640x480	120.0	120.0	23.0	8-bits
4CIF	704x576	120.0	120.0	23.0	8-bits
525 SD	720x480	120.0	120.0	23.0	8-bits
625 SD	720x568	120.0	120.0	23.0	8-bits
XGA	1024x768	79.6	79.6	23.0	8-bits
720p HD	1280x720	68.0	68.0	23.0	8-bits
4VGA	1280x960	51.0	51.0	23.0	8-bits
SXGA	1280x1024	47.8	N/A	23.0	8-bits
525 16SIF	1408x960	46.3	N/A	23.0	8-bits
16CIF	1408x1152	38.6	N/A	23.0	8-bits
4SVGA	1600x1200	32.6	N/A	23.0	8-bits
1080 HD	2048x1080	30.0	N/A	23.0	8-bits

MPEG-2 MXF interop 2D image formats

Format	Resolution	Max frame rate 2D	Max frame rate 3D	Min frame rate	Bit-depth
VGA	640x480	120.0	120.0	23.0	8-bits
525 4SIF	704x480	120.0	120.0	23.0	8-bits
525 SD	720x480	120.0	120.0	23.0	8-bits
4CIF	704x576	120.0	120.0	23.0	8-bits
625 SD	800x600	120.0	120.0	23.0	8-bits
SVGA	1024x768	79.6	79.6	23.0	8-bits
XGA	1024x768	79.6	79.6	23.0	8-bits
720p HD	1280x720	68.0	68.0	23.0	8-bits
4VGA	1280x960	51.0	51.0	23.0	8-bits
SXGA	1280x1024	47.8	N/A	23.0	8-bits
525 16SIF	1408x960	46.3	N/A	23.0	8-bits

Format	Resolution	Max frame rate 2D	Max frame rate 3D	Min frame rate	Bit-depth
16CIF	1408x1152	38.6	N/A	23.0	8-bits
4SVGA	1600x1200	32.6	N/A	23.0	8-bits
1080 HD	2048x1080	30.0	N/A	23.0	8-bits

SMPTTE-compatible 2D (JPEG 2000) cinema image formats

Specification	Resolution	Frame rate	Color format	Bit-depth
SMPTTE 428-1-2019	2048x1080	24.0	X'Y'Z' (4:4:4)	12-bits
SMPTTE 428-11-2013	2048x1080	25.0	X'Y'Z' (4:4:4)	12-bits
SMPTTE 428-11-2013	2048x1080	30.0	X'Y'Z' (4:4:4)	12-bits
SMPTTE 428-1-2019	2048x1080	48.0	X'Y'Z' (4:4:4)	12-bits
SMPTTE 428-11-2013	2048x1080	50.0	X'Y'Z' (4:4:4)	12-bits
SMPTTE 428-11-2013	2048x1080	60.0	X'Y'Z' (4:4:4)	12-bits
SMPTTE 428-1-2019	4096x2160	24.0	X'Y'Z' (4:4:4)	12-bits
SMPTTE 428-11-2013	4096x2160	25.0	X'Y'Z' (4:4:4)	12-bits
SMPTTE 428-11-2013	4096x2160	30.0	X'Y'Z' (4:4:4)	12-bits

SMPTTE-compatible 3D (JPEG 2000) cinema image formats

Specification	Resolution	Frame rate (per eye)	Color format	Bit-depth
SMPTTE 428-1-2019	2048x1080	24.0x2	X'Y'Z' (4:4:4)	12-bits
SMPTTE 428-1-2019	2048x1080	48.0x2	X'Y'Z' (4:4:4)	12-bits
SMPTTE 428-11-2013	2048x1080	60.0x2	X'Y'Z' (4:4:4)	12-bits

Series 4 Integrated Media Block (IMB) video formats

S4 Integrated Media Block (IMB) video format support is determined by the IMB make and model. Refer to the associated IMB documentation to understand which of the following video signals are supported.

All MPEG-2 content is converted in the media block to RGB 4:4:4 8-bit before play out.

MPEG image formats

Format	Resolution	Max frame rate 2D	Max frame rate 3D	Min frame rate	Bit depth
VGA	640x480	120.0	120.0	23.0	8-bits
525 4SIF	704x480	120.0	120.0	23.0	8-bits

Format	Resolution	Max frame rate 2D	Max frame rate 3D	Min frame rate	Bit depth
525 SD	720x480	120.0	120.0	23.0	8-bits
4CIF	704x576	120.0	120.0	23.0	8-bits
625 SD	800x600	120.0	120.0	23.0	8-bits
SVGA	1024x768	79.6	79.6	23.0	8-bits
XGA	1024x768	79.6	79.6	23.0	8-bits
720p HD	1280x720	68.0	68.0	23.0	8-bits
4VGA	1280x960	51.0	51.0	23.0	8-bits
SXGA	1280x1024	47.8	N/A	23.0	8-bits
525 16SIF	1408x960	46.3	N/A	23.0	8-bits
16CIF	1408x1152	38.6	N/A	23.0	8-bits
4SVGA	1600x1200	32.6	N/A	23.0	8-bits
1080 HD	2048x1080	30.0	N/A	23.0	8-bits

MPEG-2 MXF interop 2D image formats

Format	Resolution	Max frame rate 2D	Max frame rate 3D	Min frame rate	Bit depth
VGA	640x480	120.0	120.0	23.0	8-bits
525 4SIF	704x480	120.0	120.0	23.0	8-bits
525 SD	720x480	120.0	120.0	23.0	8-bits
625 SD	720x568	120.0	120.0	23.0	8-bits
4CIF	704x576	120.0	120.0	23.0	8-bits
XGA	1024x768	79.6	79.6	23.0	8-bits
720p HD	1280x720	68.0	68.0	23.0	8-bits
4VGA	1280x960	51.0	51.0	23.0	8-bits
SXGA	1280x1024	47.8	N/A	23.0	8-bits
525 16SIF	1408x960	46.3	N/A	23.0	8-bits
16CIF	1408x1152	38.6	N/A	23.0	8-bits
4SVGA	1600x1200	32.6	N/A	23.0	8-bits
1080 HD	2048x1080	30.0	N/A	23.0	8-bits

SMPTÉ-compatible 2D (JPEG 2000) cinema image formats

Specification	Resolution	Frame rate	Color format	Bit depth
SMPTÉ 428-1-2019	2048x1080	24.0	X'Y'Z' (4:4:4)	12-bits

Specification	Resolution	Frame rate	Color format	Bit depth
SMPTE 428-11-2013	2048x1080	25.0	X'Y'Z' (4:4:4)	12-bits
SMPTE 428-11-2013	2048x1080	30.0	X'Y'Z' (4:4:4)	12-bits
SMPTE 428-1-2019	2048x1080	48.0	X'Y'Z' (4:4:4)	12-bits
SMPTE 428-11-2013	2048x1080	50.0	X'Y'Z' (4:4:4)	12-bits
SMPTE 428-11-2013	2048x1080	60.0	X'Y'Z' (4:4:4)	12-bits
SMPTE 428-11-2013	2048x1080	96.0	X'Y'Z' (4:4:4)	12-bits
SMPTE 428-11-2013	2048x1080	100.0	X'Y'Z' (4:4:4)	12-bits
SMPTE 428-11-2013	2048x1080	120.00	X'Y'Z' (4:4:4)	12-bits
SMPTE 428-1-2019	4096x2160	24.0	X'Y'Z' (4:4:4)	12-bits
SMPTE 428-11-2013	4096x2160	25.0	X'Y'Z' (4:4:4)	12-bits
SMPTE 428-11-2013	4096x2160	30.0	X'Y'Z' (4:4:4)	12-bits
SMPTE 2048-1-2011 Am1:2016	4096x2160	48	X'Y'Z' (4:4:4)	12-bits
SMPTE 2048-1-2011 Am1:2016	4096x2160	50	X'Y'Z' (4:4:4)	12-bits
SMPTE 2048-1-2011 Am1:2016	4096x2160	60	X'Y'Z' (4:4:4)	12-bits
SMPTE 2048-1-2011 Am1:2016	4096x2160	96	X'Y'Z' (4:4:4)	12-bits
SMPTE 2048-1-2011 Am1:2016	4096x2160	100	X'Y'Z' (4:4:4)	12-bits
SMPTE 2048-1-2011 Am1:2016	4096x2160	120	X'Y'Z' (4:4:4)	12-bits

SMPTE-compatible 3D (JPEG 2000) cinema image formats

Specification	Resolution	Frame rate (per eye)	Color format	Bit depth
SMPTE 428-1-2019	2048x1080	24.0x2	X'Y'Z' (4:4:4)	12-bits
SMPTE 428-11-2013	2048x1080	25.0x2	X'Y'Z' (4:4:4)	12-bits
SMPTE 428-11-2013	2048x1080	30.0x2	X'Y'Z' (4:4:4)	12-bits
SMPTE 428-1-2019	2048x1080	48.0x2	X'Y'Z' (4:4:4)	12-bits
SMPTE 428-11-2013	2048x1080	50.0x2	X'Y'Z' (4:4:4)	12-bits
SMPTE 428-11-2013	2048x1080	60.0x2	X'Y'Z' (4:4:4)	12-bits
SMPTE 428-1-2019	4096x2160	24.0x2	X'Y'Z' (4:4:4)	12-bits
SMPTE 428-11-2013	4096x2160	25.0x2	X'Y'Z' (4:4:4)	12-bits
SMPTE 428-11-2013	4096x2160	30.0x2	X'Y'Z' (4:4:4)	12-bits

Specification	Resolution	Frame rate (per eye)	Color format	Bit depth
SMPTE 2048-1-2011 Am1:2016	4096x2160	48.0x2	X'Y'Z' (4:4:4)	12-bits
SMPTE 2048-1-2011 Am1:2016	4096x2160	50.0x2	X'Y'Z' (4:4:4)	12-bits
SMPTE 2048-1-2011 Am1:2016	4096x2160	60.0x2	X'Y'Z' (4:4:4)	12-bits

HDMI video source connection from an Integrated Media Block (IMB)

The projector can accept digital video data from HDMI sources connected to applicable Integrated Media Block (IMB) devices. The input configurations supported are determined by the IMB device directly.

Contact Christie Technical Support to learn which IMB devices provide HDMI source selection from the projector user interface.

HDMI input selection directly from the IMB may also be possible using the IMB user interface. The input configurations supported are determined by the IMB make and model.

SDI video source connection from an Integrated Media Block (IMB)

The projector can accept digital video data from SDI sources connected to applicable Integrated Media Block (IMB) devices.

The input configurations supported are determined by the IMB device directly. Contact Christie Technical Support to learn which IMB devices provide SDI source selection from the projector user interface.

SDI input selection directly from the IMB may also be possible using the IMB user interface. The input configurations supported are determined by the IMB make and model.

GPIO connector

The Generic Purpose Input Output (GPIO) connector provides a flexible method of interfacing with the projector. 18 GPIO pins are available on the GPIO connector. Two other pins are reserved for ground and power.

The GPIO connector is located on the input panel (*M in the Video Input panel image (on page 58)*).

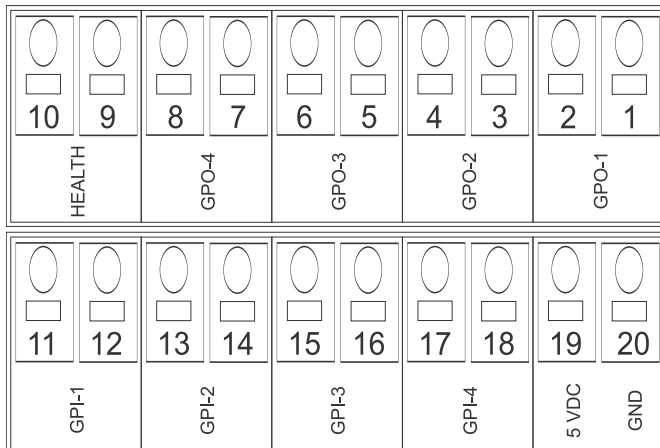

Pin number	Signal name	Direction
Pin 1	GPO1_POS	Out
Pin 2	GPO1_NEG	Out
Pin 3	GPO2_POS	Out
Pin 4	GPO2_NEG	Out
Pin 5	GPO3_POS	Out
Pin 6	GPO3_NEG	Out
Pin 7	GPO4_POS	Out
Pin 8	GPO4_NEG	Out
Pin 9	HEALTH_POS	Out
Pin 10	HEALTH_NEG	Out
Pin 11	GPI1_POS	In
Pin 12	GPI1_NEG	In
Pin 13	GPI2_POS	In
Pin 14	GPI2_NEG	In
Pin 15	GPI3_POS	In
Pin 16	GPI3_NEG	In
Pin 17	GPI4_POS	In
Pin 18	GPI4_NEG	In
Pin 19	+5V	—
Pin 20	GND	—

GPIO inputs

The 5 VDC (pin 19 and pin 20) is intended for use to supply the inputs.

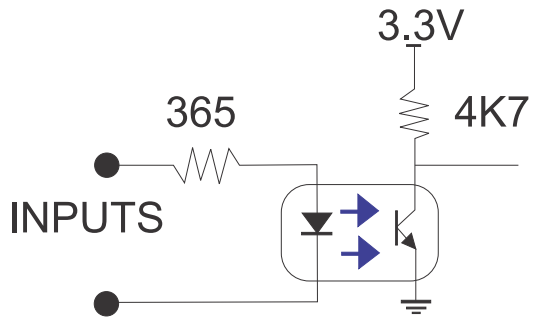

GPIO outputs

Outputs are solid state relays with a 1 A AC/DC rating at up to 48 V.

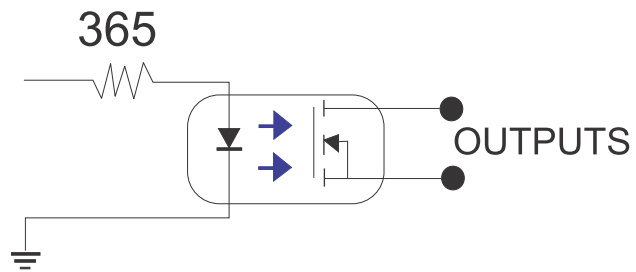

Managing the light source

Learn how to configure a laser file and use the projector's LiteLOC™ feature.

Use the laser file to control the power settings of the red, green, and blue (RGB) lasers. The LiteLOC™ feature ensures that color and brightness are held at the level you set.

Create multiple laser files to manage varying screen sizes, brightness requirements, room temperatures in the projection booth, and types of content (such as 2D, 3D, and alternative content).

For external chiller-based projectors, the laser files also contain maximum expected humidity.

Creating a new laser file for external chiller-based projectors

Create a laser file to store the power settings for the RGB laser light source and the maximum expected relative humidity.

To make sure color and brightness are held at the required levels for your installation, enable LiteLOC™ for each laser file you create. If you make significant change to the brightness level when refining the laser power settings, it takes a few minutes for the color and brightness to stabilize.

1. Log in as service.
2. Turn on the laser.
3. For systems upgraded to v1.5.0 and already using the calibration file, set a channel to use the appropriate calibration file and activate the channel.
4. Display a test pattern, such as DC4K 17 L Point, to locate the center of the screen.
5. Set up the color meter to aim at the center of the screen.
6. In the left navigation menu, select **Laser Settings > Laser Power/LiteLOC Setup**.
7. Select the **Display White Test Pattern** slider.
8. To create a new laser file, select **Create**. 
9. In the Create dialog, enter a name for the new laser file and select **Create**.
10. Set the maximum expected humidity.
The projector uses this information and the ambient temperature to determine the optimum maximum brightness allowed.
11. In the White Coordinates dialog, set the required white point.
For a typical cinema setup, the white point is Digital Cinema Initiative (DCI) white $x=0.314$ and $y=0.351$.
12. Select **Apply**.

13. Adjust the brightness level until you achieve the required brightness at the specified white point.
14. If the laser file will be associated with a 3D channel, complete the following steps:
 - a) Engage the 3D system in the light path by enabling **3D Sync** when selecting the test pattern.
 - b) Mount a 3D glass or filter on the color meter to measure the brightness through the glasses.
 - c) Select **3D Sync** on the LiteLOC™ setup page.
 - d) Adjust the brightness level until you achieve the required brightness while the 3D system is engaged.
15. To save the new laser file, select **Save** .

Modifying an existing laser file

Modify the settings in the laser file to change the laser power settings or the chiller setpoint.

If you make significant change to the brightness level when refining the laser power settings, it takes a few minutes for the color and brightness to stabilize.

1. Log in as service.
2. Turn on the laser.
3. Display a test pattern, such as DC4K 17 L Point, to locate the center of the screen.
4. In the left navigation menu, select **Laser Settings > Laser Power/LiteLOC Setup**.
5. To begin modifying the settings, select **Display White Test Pattern**.
6. From the Laser File list, select the laser file to edit.
7. For external chiller-based projectors only, set the maximum expected humidity.
The projector uses this information and the ambient temperature to determine the optimum Chiller set temperature.
8. In the White Coordinates dialog, set the required white point.
For a typical cinema setup, the white point is DCI white $x=0.314$ and $y=0.351$.
9. Select **Apply**.
10. Set the brightness levels as required for your projection environment and allow the projector to stabilize for a few minutes.
System stability may be affected if you set a power level below the minimum power level recommended.
11. If white or brightness is not at the target level, adjust the settings to achieve the target and allow the projector to re-stabilize for an additional three to five minutes.



The projector is considered stable when no further adjustments are required and you obtain the same screen state results after two sets of measurements, five minutes apart.

12. To save the new settings, select **Save** .

Copying existing laser settings to a new file

Copy an existing laser file when creating a new file with similar settings.

1. In the left navigation menu, select **Laser Settings > Laser Power/LiteLOC Setup**.
2. From the Laser File list, select the file to copy.
3. To save the new laser file, select **Save As.** 
4. Enter a new name for the laser file and then select **Save**.
5. Adjust the settings as required for the new configuration.
6. Select **Save**.

Deleting a laser file

Delete a laser file when the configuration is no longer required.

1. In the left navigation menu, select **Laser Settings > Laser Power/LiteLOC Setup**.
2. In the Laser File list, select the file to delete.
3. Select **Delete.** 
4. To confirm the deletion, select **Delete**.

LiteLOC™ sensor-to-screen™ calibration

The LiteLOC™ sensor-to-screen calibration is performed in the factory under specific setup conditions which include the type of lens, screen, and the spectroradiometer used for measuring screen color and brightness.

Your projector's setup conditions may not match the factory setup which may result in a discrepancy in color accuracy. Upon first installation, check the accuracy of the color point and if unsatisfactory, perform this calibration. Doing this calibration captures all the variables of your setup and achieves the best results. By doing this calibration, you will not overwrite the factory calibration. Once satisfied, some scenarios may exist in which you may need to re-do the calibration in the future.

Re-doing this calibration is required if the following is replaced:

- Color sensor board

Christie recommends re-doing this calibration if any of the following are replaced:

- Light engine
- Lens
- Laser optical subsystem (LOS)
- Screen
- Port window
- Any other optical components in the optical path between the LOS and the screen

After replacing these components, check the accuracy of the color point and if unsatisfactory, re-do this calibration.

LiteLOC™ sensor-to-screen calibration: Workflow

Identify the recommended order for performing the sensor-to-screen calibration.



LiteLOC™ sensor-to-screen calibration requires the following:

- Spectroradiometer
- Service user is the minimum level user access
- *Create a new calibration file* (on page 79).
- *Recalibrate the calibration file* (on page 80), if required.
- *Edit the existing calibration file parameters* (on page 81) on the Sensor-to-screen menu, if required.
- *Verify the calibration* (on page 82), if required.
- *Add the calibration file to the Channel Setup* (on page 82).

Creating a new calibration file

The Sensor-to-screen Calibration wizard guides you through the steps required to create a new calibration file.

1. Set up a spectroradiometer to obtain screen measurements later in the process.
2. In the left navigation menu, select **Color Settings > Sensor-to-screen Calibration**.
3. To create a new calibration file, select **Create** .

The projector checks if the light source is on and the douser is open. If either condition is not met, a warning dialog is displayed prompting you to make sure these conditions are met before starting the wizard.

4. In the Create dialog, enter a name for the new calibration file and select **Create**.
5. In step 1 of the Sensor-to-screen Calibration wizard, set the maximum brightness and color point.
 - a) Enable the **Display White Test Pattern** option.
 - b) To set the maximum expected room and chiller (for chiller-based products) temperatures, use the plus (+) or minus (-) signs.
 - c) Adjust the RGB sliders to set the brightness and color point.
 - d) Select **Next**.
6. Wait 20 minutes for the projector to stabilize or select **Skip** during the stabilization time period.
7. In step 2 of the Sensor-to-screen Calibration wizard, measure and enter the screen values.
 - a) To trigger the measurement at a specific operating point, under Sensor to screen, select **Capture**.

The Capture button changes color to indicate the capture process is activated. Only one Capture button is active at a time but the buttons can be selected in any order.

The projector automatically sets the red, green, and blue output laser powers to the pre-determined settings calculated and displayed in the Drive Percentage (Calculated) area of the wizard.

A 10 second countdown begins to allow the projector white point and brightness to stabilize and no changes can be made. At the end of the countdown period, the Color

- Sensor values fields are automatically populated by the projector for the currently selected drive percentage value.
- b) When the countdown ends, take x, y, and fL measurements using the spectroradiometer. Christie recommends taking meter readings from the center of the screen to obtain accurate screen measurements.
 - c) Under Measured Values, using the numeric keypad record the associated spectroradiometer values for x, y, and fL.
The projector holds the on-screen color and brightness level until the same or another Capture button is selected.
 - d) Repeat steps a to c for the remaining drive percentage set points until all x, y, and fL values are entered.
Spectroradiometer measurements can be captured in any order but all three x, y, and fL measurements must be entered before moving onto the next capture. You can recapture a specific measurement at any time during the process by selecting the Capture button. In this case, the measured spectroradiometer and color sensor values are reset.
 - e) Once all the color sensor and measured values are entered for all nine rows, select **Apply and Save**.
8. Verify and complete the calibration.
- a) Select a white point to measure by selecting either the **DCI, D65**, or **Custom** white point buttons.
Once selected, the projector automatically enables LiteLOC™, selects a White test pattern with uncorrected colors at the white point specified, and sets the brightness to 80%.
 - b) Using a spectroradiometer, measure screen x and y values at the center of the screen.
To verify the calibration has been successfully applied, the measured white point must be within the expected tolerance.
 - c) When complete, select **Finish**.
The projector output is configured according to the currently selected calibration file and you are returned to the Sensor-to-screen Calibration menu.

Recalibrating an existing calibration file

The Sensor-to-screen Calibration wizard guides you through the steps required to re-calibrate an existing calibration file, if required.

1. Select **Menu > Color Settings > Sensor-to-screen Calibration**.
2. Select a user-defined calibration file to recalibrate.
3. Select **Recalibrate**.
The projector checks if the light source is on and the douser is open. If either condition is not met, a warning dialog is displayed prompting you to make sure these conditions are met before starting the wizard.
4. In step 1 of the Sensor-to-screen Calibration wizard, set the maximum brightness and color point.
 - a) Enable the **Display White Test Pattern** option.
 - b) To set the maximum expected room and chiller (for chiller-based products) temperatures, use the plus (+) or minus (-) signs.
 - c) Adjust the RGB sliders to set the brightness and color point.
 - d) Select **Next**.

5. Wait 20 minutes for the projector to stabilize or select **Skip** during the stabilization time period.
6. In step 2 of the Sensor-to-screen Calibration wizard, measure and enter the screen values.
 - a) To trigger the measurement at a specific operating point, under Sensor to screen, select **Capture**.

The Capture button changes color to indicate the capture process is activated. Only one Capture button is active at a time but the buttons can be selected in any order.

The projector automatically sets the red, green, and blue output laser powers to the pre-determined settings calculated and displayed in the Drive Percentage (Calculated) area of the wizard.

A 10 second countdown begins to allow the projector white point and brightness to stabilize and no changes can be made. At the end of the count down period, the Color Sensor values fields are automatically populated by the projector for the currently selected drive percentage value.
 - b) When the countdown ends, under Measured Values, using the numeric keypad capture and record the associated spectroradiometer values for x, y, and fL.

The projector holds the on-screen color and brightness level until the same or another Capture button is selected.
 - c) Repeat steps a and b for the remaining drive percentage set points until all x, y, and fL values are entered.

Spectroradiometer measurements can be captured in any order but all three x, y, and fL measurements must be entered before moving onto the next capture. You can recapture a specific measurement at any time during the process by selecting the Capture button. In this case, the measured spectroradiometer and color sensor values are reset.
 - d) Once all the color sensor and measured values are entered for all nine rows, select **Apply and Save**.
7. Verify and complete the calibration.
 - a) Select a white point to measure by selecting either the **DCI**, **D65**, or **Custom** white point buttons.

Once selected, the projector automatically enables LiteLOC™, selects a White test pattern with uncorrected colors at the white point specified, and sets the brightness to 80%.
 - b) Using a spectroradiometer, measure screen x and y values at the center of the screen.

To verify the calibration has been successfully applied, the measured white point must be within the expected tolerance.
 - c) When complete, select **Finish**.

The projector output is configured according to the currently selected calibration file and you are returned to the Sensor-to-screen Calibration menu.

Editing the existing calibration file parameters

Make corrections to the existing calibration file parameters, when the values from the spectroradiometer were entered in error.

1. Select **Menu > Color Settings > Sensor-to-screen Calibration**.
2. Select a user-defined calibration file.
3. Edit any of the x, y, or fL values by selecting the field under Measured Values and using the numeric keypad to enter the updated value.
 - x and y value range: 0.0001 to 0.9999

- fL value range: 0.01 to 9999.99.
4. To save the updated file to the projector, select **Save**.

Verifying the sensor-to-screen calibration

Check the integrity of the calibration, if required.

1. Navigate to **Menu > Color Settings > Sensor-to-screen Calibration**.
2. In the right toolbar, select **Test Patterns**. 
3. Select the **White** test pattern.
4. Close the Test Patterns window.
5. Select **Verify Calibration**.

If the douser is closed and/or the light source is off, a dialog is displayed informing the user that the douser must be open and the light source turned on before verification can occur.

Step 3 of the Calibration wizard opens.

6. Verify and complete the calibration.
 - a) Select a white point to measure by selecting either the **DCI**, **D65**, or **Custom** white point buttons.

Once selected, the projector automatically enables LiteLOC™, selects a White test pattern with uncorrected colors at the white point specified, and sets the brightness to 80%.
 - b) Using a spectroradiometer, measure screen x and y values at the center of the screen.

To verify the calibration has been successfully applied, the measured white point must be within the expected tolerance.
 - c) When complete, select **Finish**.

The projector output is configured according to the currently selected calibration file and you are returned to the Sensor-to-screen Calibration menu.

Adding a calibration file to the Channel Setup

Select any of the available calibration files stored on the projector system by accessing the 2D Sensor-to-Screen Calibration File or 3D Sensor-to-Screen Calibration File list in the Channel Setup menu.

By default, the 2D and 3D sensor-to-screen calibration files are set to the factory or field calibration data identified as Default in the list. The Default selection references the factory calibration data as long as no field calibration data is available. If field calibration data is available, it is selected as the Default. When a 2D and 3D Sensor-to-screen Calibration file is selected in the Channel Setup, the active channel automatically applies the calibration data according to the 2D or 3D operation of the projector.

1. In the left navigation menu, select **Channel Setup**.
2. Select the channel you want to add the calibration file to.
3. From either the **2D Sensor-to-Screen Calibration File** or **3D Sensor-to-Screen Calibration File** list, select the calibration file.
4. Select **Save**.

Adjusting the image

Learn how to adjust image geometry so it displays correctly.

Calibrating the Intelligent Lens System

On CP4445-RGB and CP4455-RGB projectors, the Intelligent Lens System (ILS) is activated by default.

Use the Auto Calibrate feature of the ILS to find and compensate for motor backlash, and to determine the movement range for the currently installed lens.

1. In the left navigation menu, select **Image Settings > ILS File Setup**.
2. From the ILS File list, select an available ILS file.
3. Select **Auto Calibrate**.
4. Select **Continue**.
The system performs the lens calibration.

Correcting vignetting

An image that is brighter at the center than it is at the sides needs vignetting correction.

If your image suffers from vignetting, the lens has reached the end of its offset travel range.

If your installation does not allow the image to be centered with the center of the screen, move the entire projector in the direction of lens travel.

Adjusting tilt and leveling the projector

To ensure optimum performance, install the projector so it is centered and parallel with the screen.

To compensate for tilt or offset, you can adjust the projector feet and the lens mount position.

This product must be installed in a landscape orientation, with all four feet supported on a level surface. Do not install or operate the projector in an inverted position. If your site has any installation requirements other than a typical theater projection booth, contact Christie for assistance.



The front-to-back tilt of the projector must not exceed 15° in a downward direction or 3° in an upward direction. The side-to-side tilt must be within +3° to -3° of level.

1. To adjust the height of the projector, loosen the lock nut on the adjustable feet on the bottom of the projector.

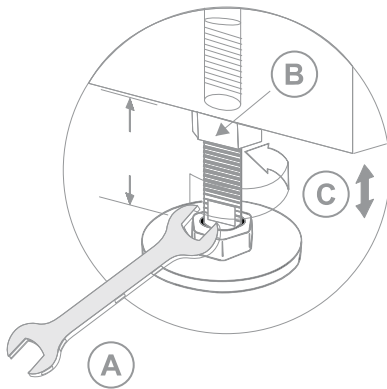

A	Adjustable wrench for 18 mm - 24 mm
B	Lock
C	Turn to adjust height

2. Extend or retract the feet.
3. When the adjustment is correct, tighten the lock nut.

Correcting keystone effect

Keystone effect occurs when you project an image onto the screen at an angle. As a result, the image appears distorted and resembles a trapezoid.



When making the adjustments, set the light source to minimum power.

Horizontal keystone	Vertical keystone
Projector skewed horizontally to the screen	Projector tilted vertically to the screen

1. If the image suffers from slight keystone effect, it can be corrected with electronic cropping.
2. If the keystone effect is severe, unevenly adjust the feet to compensate for projector tilt.

Christie recommends using the lens offset to align the center of the image to the center of the screen before correcting the keystone effect.

3. If one side of the image is longer than another, adjust the tilt and level of the projector.

Displaying a test pattern

Display a test pattern to refine and adjust the projected image or to diagnose and correct image issues.

1. In the right toolbar, select **Test Patterns**. 
2. Select **Full Screen**.
3. Select a test pattern.
When a test pattern is active, a blue bar appears below the test pattern icon in the right pane.
4. To display a 2D test pattern in 3D mode, select the **3D Sync** option.
The **3D Sync** option is selected automatically for 3D test patterns. 3D test patterns cannot be displayed in 2D mode.
5. To change the frame rate of the test pattern display, select from the available Frame Rate options:
 - For 2D test patterns, the available frame rates are 24, 30, 48, and 60 Frames Per Second (FPS). The default value is 24 FPS.
 - For 3D test patterns, the available frame rates are 48 and 60 FPS. The default value is 48 FPS.

Changing the frame rate of the display can assist with color measurement when working with corrected colors.

When changing the frame rate option, the option is applied to the next test pattern you select unless it is not available for that pattern. If a selected frame rate is not available, the default frame rate is applied for the test pattern display.

Adjusting the integrator rod and fold mirror

Understand how to adjust the integrator rod and fold mirror to control the illumination spot on the digital micromirror device (DMD).

Extreme misalignment of projection optics can cause permanent damage to critical optical components. Only Christie qualified technicians can perform internal optical adjustments.

The integrator rod and fold mirror adjustments are set by Christie. Make adjustments only if screen shadows are visible.



When adjusting the fold mirror, set the light source to minimum power.

1. In the right toolbar, select **Test Patterns**. 
2. Set the Laser power to less than 40%.
High power and misalignment can damage the DMDs.
3. Select the **RGB-4K-Integrator Rod** test pattern and display it full screen.

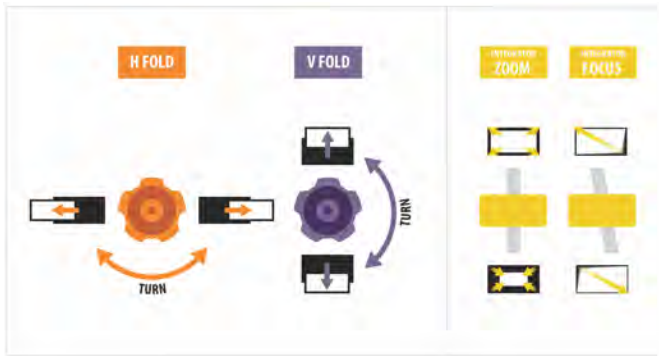

Refer to the test pattern for guidance on making the adjustments. The right panel of the test pattern provides information about the integrator zoom and focus adjustments. The left panel provides information about the fold mirror adjustments.

4. Open the Service door on the side of the projector.
5. To use the integrator rod optical controls, open the access door for the Zoom and Focus paddles.

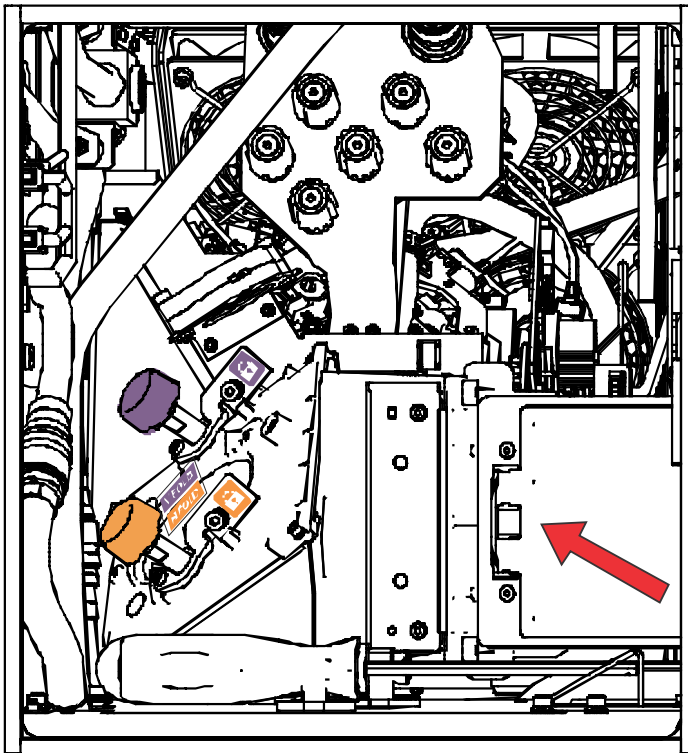

6. Loosen the lock screw for the Zoom and Focus paddles.

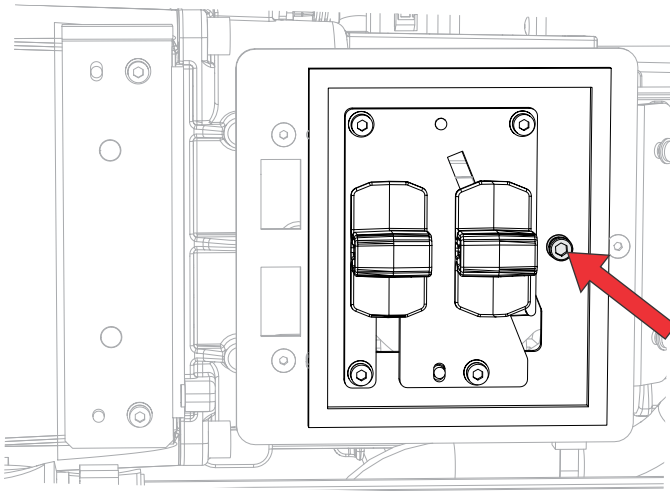

7. Set the integrator rod Zoom paddle to the minimum.
8. Loosen the fold mirror screws to unlock the fold mirror adjustment knobs.

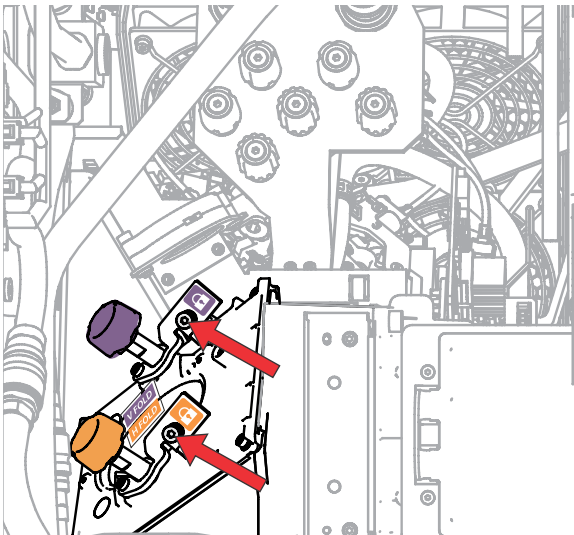

9. To make horizontal adjustments on the fold mirror, use the orange adjustment knob.
To make vertical adjustments on the fold mirror, use the purple adjustment knob.

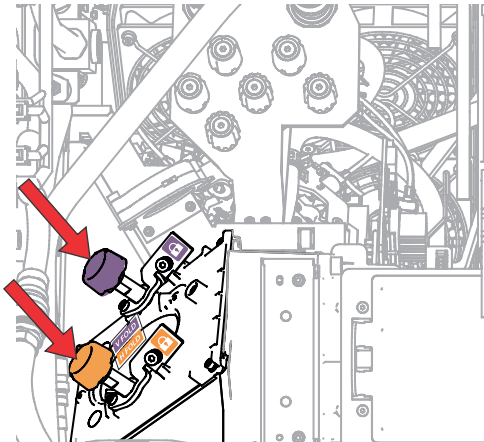

10. Adjust the fold mirror until either the top left edge or the bottom right edge of the illumination spot becomes visible on the DMD.
11. Adjust the integrator rod Focus paddle to optimize focus for one of the following:
 - Along the top edge of the image, approximately one-third across the image from the left.
 - Along the bottom edge of the image, approximately one-third across the image from the right.
12. Adjust the fold mirror to center the image on the DMD array.
13. Use the integrator rod Zoom paddle to increase the zoom until the entire active area is filled, with no dark areas at the edges or corners.
Make sure the overfill is minimized to improve DMD life and system optical efficiency for brightness.
14. Once the adjustments are complete, tighten the lock screw for the Zoom and Focus paddles and the two fold mirror screws.
15. Close the access door for the Zoom and Focus paddles.

Adjusting boresight

A boresight adjustment balances the tilt of the lens mount to compensate for screen-to-projector tilt.



Warning! If not avoided, the following could result in death or serious injury.

- Do not look directly into the lens when the light source is on. The extremely high brightness can cause permanent eye damage.
- FIRE HAZARD! Keep hands, clothes, and all combustible material away from the concentrated light beam of the projector.



Caution! If not avoided, the following could result in minor or moderate injury.

- This procedure must be performed by Christie qualified technicians.



When making the adjustments, set the light source to minimum power.

The following steps are intended to achieve the highest quality image distributed across the full screen.

1. Close the shutter on the projector to avoid accidental exposure to the projection beam when working in close proximity to the projection lens.

2. Unlock the horizontal and vertical lock screws (locks B, C, and E).

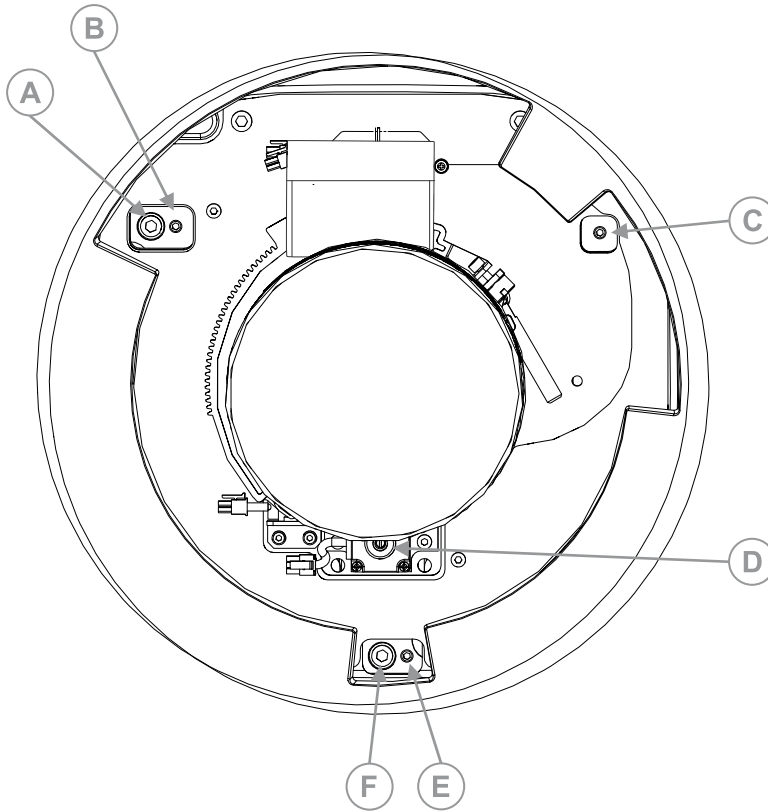

A	Horizontal boresight screw
B	Horizontal lock screw (lock A)
C	Horizontal lock screw (lock B)
D	Manual focus knob
E	Vertical lock screw (lock C)
F	Vertical boresight screw

3. Open the shutter on the projector.
4. In the right toolbar, select **Test Patterns** .
5. Select the **RGB-4K-Boresight** pattern and display it full screen. Make sure the **Uncorrected Color Box** option is selected.

Repeat for the vertical lock screw (lock E in the image in step 2).

Continue the gradual tightening of each screw, until all lock screws are tight.



When stabilizing image vibration, lock C may be left locked or unlocked at the discretion of the installer.

15. If you used the focus knob (D in the image in step 2) to make the adjustments manually, run an ILS auto calibration.
16. Fine tune the focus on cross-hair patterns **I** (horizontal) and **II** (vertical) using the ILS controls only.

The goal is to obtain good focus at the center and on all sides of the screen, including the square patterns across the screen.

Adjusting digital micromirror device (DMD) convergence

A convergence problem occurs when one or more projected colors (red, green, and blue) appears misaligned when examined with a convergence test pattern.

Adjusting the convergence is accomplished by aligning a red, green and blue sprite, which is displayed at the four corners of the displayed image. For electronic convergence all three colors can be adjusted.

Always align the color components of the sprite to the inner most line color (for each axis). When converged, the three colors should overlap to form white lines. Applying the sprite alignment settings to the screen results in the three colors overlapping to form white lines throughout the image.

One or more poorly converged individual colors may appear adjacent to some or all of the lines.

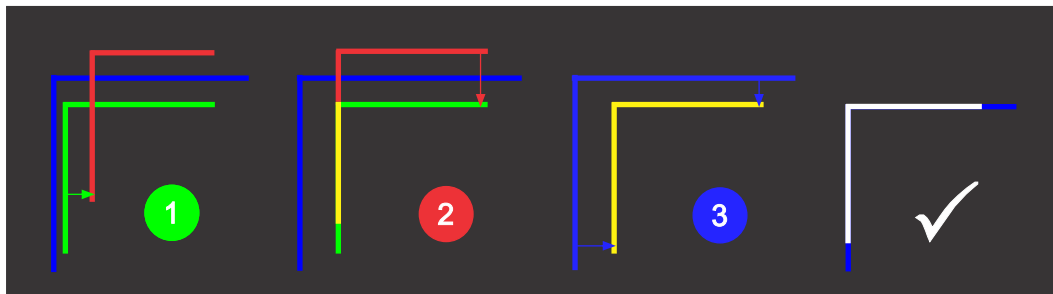

If you wear glasses with corrective lenses when performing this adjustment, make sure you are viewing the test pattern on a straight angle through the optical axis of your glasses and not from a tilted or angled perspective. This avoids a prismatic effect that can appear to shift convergence when viewing at an angle.

Mechanically adjusting digital micromirror device (DMD) convergence

A convergence problem can be identified when one or more projected colors (red, green, and blue) appears misaligned when examined with a convergence test pattern.

When adjusting the convergence, you are adjusting red and green to blue.

1. Before adjusting digital micromirror device (DMD) convergence, make sure the projector has reached a steady operational state.

If switching from a white or bright test pattern to a dark convergence test pattern or if warming up the projector after a shutdown, allow 15 minutes for stabilization so the optics can reach a steady state.

2. Make sure the electronic convergence (ECC) is defaulted before doing mechanical convergence.
3. In the right toolbar, select **Test Patterns**. 
4. Select the **RGB-4K-Convergence** test pattern and display it full screen. Make sure the **Uncorrected Color Box** option is selected.

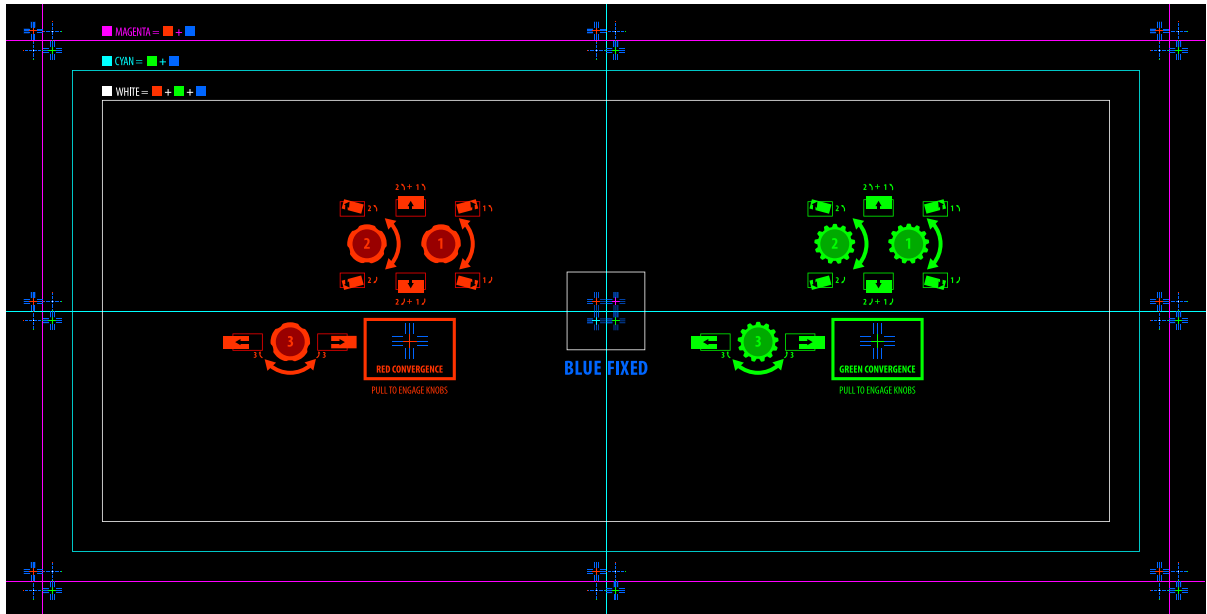

5. Open the Service door on the side of the projector.
6. To adjust the convergence knobs, use the 3 mm driver included with the projector.
If adjusting by hand without using the tool, pull out the convergence adjustment knobs to engage them.

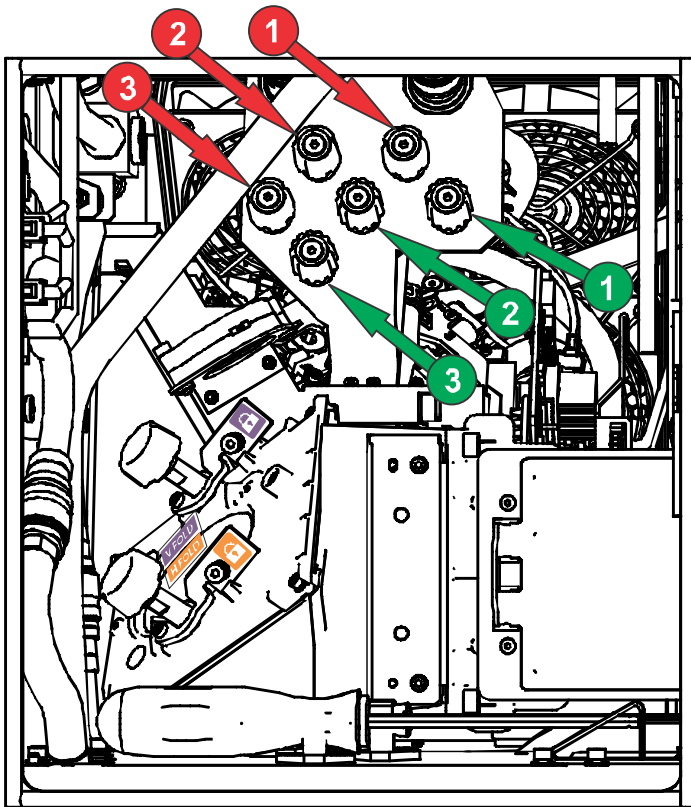

7. Use the Convergence test pattern to assist with adjusting the horizontal and vertical lines. Horizontal adjustments are controlled by adjusting knob 3. Vertical convergence and rotation are controlled by adjusting knobs 1 and 2. Christie recommends rotating a single knob a maximum of a quarter rotation before adjusting the second knob a quarter rotation. For example, if using one hand, turn the left knob a quarter rotation and then the right knob a quarter rotation, and so on. Adjusting a single knob for vertical or rotational adjustment to an extreme before adjusting the second knob may result in the convergence mechanism binding.



For the best stability, Christie recommends setting convergence while rotating the knobs in a clockwise direction. This may require first adjusting convergence by turning the knobs counter-clockwise and finalizing the convergence with a clockwise approach. This applies to all knobs.

8. When complete, push in all the convergence adjustment knobs to disengage them. If the colors at the corners of the screen require further correction, see *Electronically adjusting convergence* (on page 93).

Electronically adjusting convergence

Use the electronic convergence feature in the menu to adjust convergence. Only perform electronic convergence when satisfied with the position of the image on the screen.

1. In the left navigation menu, select **Image Settings > ILS File Setup**.
2. Use the arrow to select an ILS file to store the ECC settings.
3. On the ILS File Setup page, select **ECC**. 

Each corner of the screen displays three separate sprites, one for each primary color. The user interface displays the Test Pattern controls.

4. Set the Screen Type to **Flat** or **Scope**.
This sets the test pattern and the location of the sprites on the screen. Each sprite appears as the letter L.
5. Set the Sprite Color to **Move** and **Show**.
When first opening the ECC, all Show and all Move colors are selected, so all three sprites are displayed and all three sprites are moved by the directional pad.
6. Select a **Step Size** to control the granularity of the steps from coarse (1/8 pixel per step) to fine (1/64 pixel per step) when using the directional pad.
Sprites can be moved a maximum of 20 pixels.
7. Choose a corner by selecting the circle at a corner of the dashed rectangle.
The selected corner is indicated by a green circle. The X/Y pixel offset (from no correction) displays in red, green, and blue text corresponding to each sprite.
8. Use the directional pad to move the sprites towards the center of the screen.
9. Adjust each sprite so they overlap to create a single white sprite.
In the example below, the red sprite (in image 1 below) was moved down and the blue sprite (in image 1 below) was moved to the right so they overlap to create the single white sprite (image 2 below).

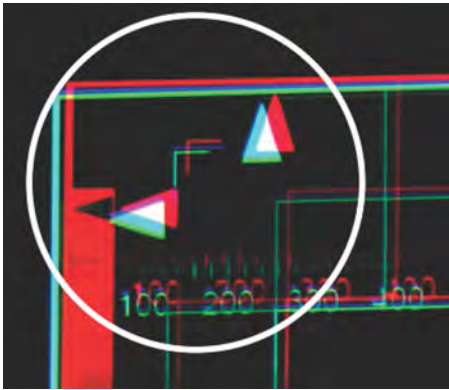

1

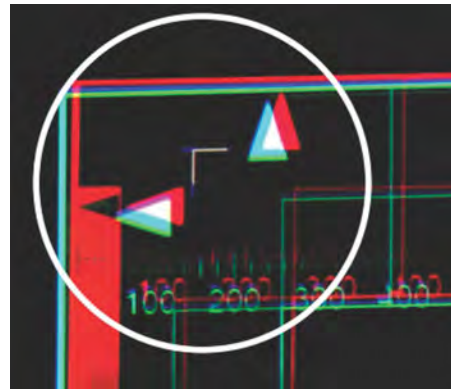

2

10. To set the convergence for that corner of the screen, select **Apply**.



11. Repeat steps 7 to 10 for the remaining corners.
12. If necessary, reset the correction back to zero (no correction) or the previously saved correction by selecting **Reset**.
In the Reset dialog, reset the current corner or all four corners. When the locations and value are set, select **Reset**.
13. To save the current ECC settings, when the convergence is complete, select **Save** beside the ILS file named at the top of the panel.

Regulatory

This product conforms to the latest regulations and standards related to product safety, environmental, and electromagnetic compatibility (EMC) requirements.

Safety

- ANSI Z136.1 (2014) – Safety of Lasers
- IEC 62368-1:2014 - Audio/Video, Information And Communication Technology Equipment - Part 1: Safety Requirements
- IEC/EN 60825-1 – Safety of Laser Products – Part 1: Equipment Classification and Requirements
- IEC 60950-1 IEC/EN 60950-1 – Information Technology Equipment – Safety – Part 1: General Requirements
- IEC 62471 – Photobiological safety of lamps and lamp systems
- IEC/EN 62471-5 – Photobiological Safety of Lamps and Lamp Systems – Part 5: Image projectors
- IEC 62368-1:2018
- EN 62368-1:2014 + A11:2017
- UL 62368-1 3rd Edition
- CSA CAN/CSA-C22.2 No. 62368-1 2nd Edition
- CSA C22.2 No. 62368-1:19
- AS/NZS 62368.1:2022
- EN IEC 62368-1:2020+A11:2020
- BS EN IEC 62368-1:2020+A11:2020

Electro-magnetic compatibility

Emissions

- CAN ICES-003 (A)/NMB-003 (A) – Information Technology Equipment (Including Digital Apparatus) – Limits and Methods of Measurement
- CISPR 32/EN 55032, Class A – Electromagnetic Compatibility of Multimedia Equipment – Emission Requirements
- FCC CFR47, Part 15, Subpart B, Class A – Unintentional Radiators
- IEC 61000-3-2/EN61000-3-2: Limits for harmonic current emissions for equipment with input current ≤ 16 A

- IEC 61000-3-3/EN 61000-3-3: Limitations of Voltage Changes, Voltage Fluctuations, and Flicker input current ≤ 16 A per phase and not subject to conditional connection

Immunity

- CISPR 35/EN 55035 Electromagnetic compatibility of multimedia equipment - Immunity requirements

California law on security

- California Law Requiring Internet Connected Devices To Include Reasonable Security Features (California Civil Code Section 1798.91.04)

Environmental

- China Ministry of Information Industry (along with 7 other Government Agencies) Order No.32 (01/2016) on the control of pollution caused by electronic information products, hazardous substances concentration limits (GB/T 26572 - 2011), and the applicable product marking requirement (SJ/T 11364 - 2014).
- EU Directive (2011/65/EU) on the restriction of the uses of certain hazardous substances (RoHS) in electrical and electronic equipment and the applicable official amendment(s).
- EU Directive (2012/19/EU) on waste and electrical and electronic equipment (WEEE) and the applicable official amendment(s).
- Regulation (EC) No. 1907/2006 on the registration, evaluation, authorization and restriction of chemicals (REACH) and the applicable official amendment(s).

