

Zoom Lens Motor kit installation

This instruction sheet describes how to install the Zoom Lens Motor kit.

Affected products

The Zoom Lens Motor kit is applicable for products that do not have an integrated zoom and focus on the lens.

- All Christie Series 2 Cinema projectors with 1.2" 2K DMD or 1.3" 4K DMD
- All Christie CineLife™ Series 3 Cinema projectors with 1.2" 2K DMD or 1.3" 4K DMD
- All Christie CineLife+™ Series 4 Cinema projectors with 1.2" 2K DMD or 1.3" 4K DMD
- E3LH+TPLS

Required tools and available components

The following tools are required to install one of the Zoom Lens Motor kits or assemblies.

Required tools

- 2.5 mm hex driver
- 3 mm hex driver

Available components

- Zoom Lens Motor assembly (P/N: 000-202552-XX)
- Zoom Motor kit (P/N: 003-202552-XX)
- Zoom Hardware kit (P/N: 003-007515-XX)

The following image shows the Zoom Lens Motor kit installed on the lens:

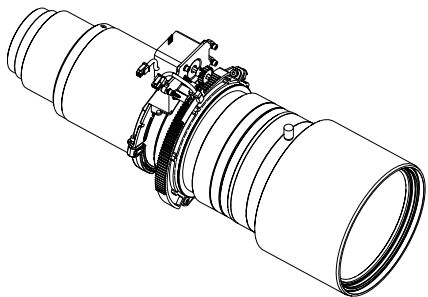

The following image shows the main components of the Zoom Lens Motor kit:

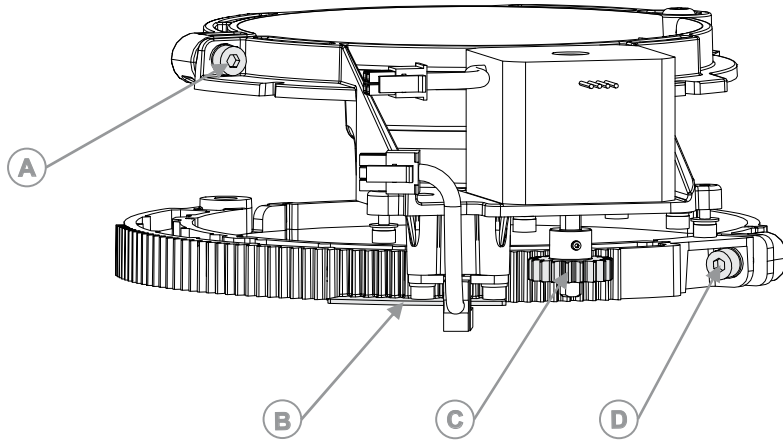

- A Motor clamp screws
- B Gear tab
- C Gear teeth
- D Gear clamp screw

Installing the Zoom Lens Motor kit

Follow these steps to install the Zoom Lens Motor kit.

1. Remove the three screws securing the zoom motor cover.

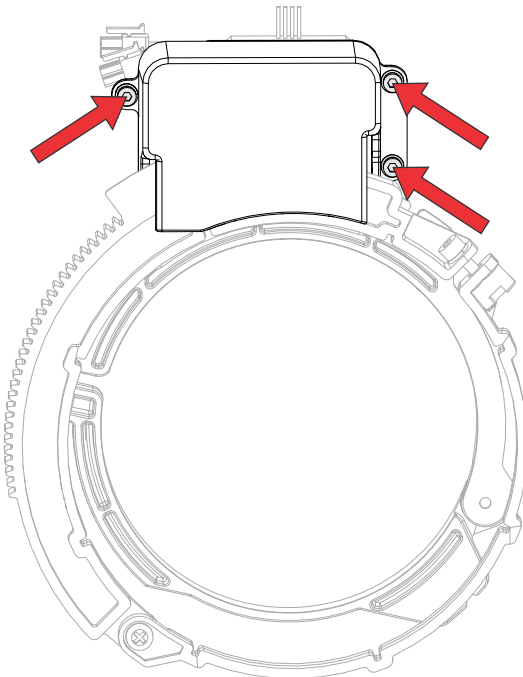

2. Slide the motor clamp onto the lens making sure to align the motor (arrow) with the lens center indicator or the UP label.

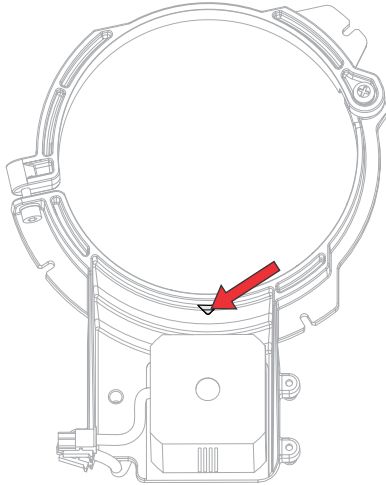

3. Determine the orientation for the position plate hooks.
 - For enhanced 4K lenses, use the A hooks (A in the image below).
 - For all non-enhanced lenses, use the B hooks (B in the image below).

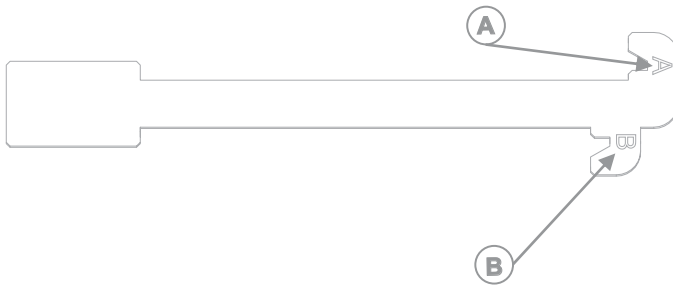

To determine if your lens is an enhanced lens, look for the word *enhanced* on the lens.

4. Install the alignment ring with the tabs pointing up and align the center mark to the motor ring arrow from step 2.

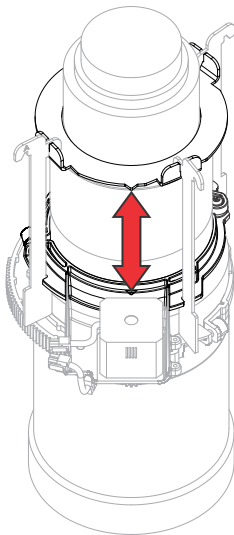

5. Use the alignment ring and the three position plates to position the motor clamp.

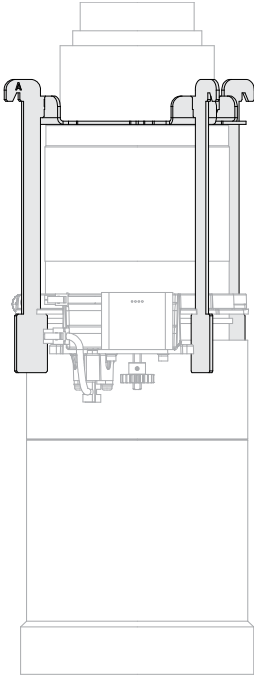

6. Adjust until the motor clamp is seated on the shoulder position plates.

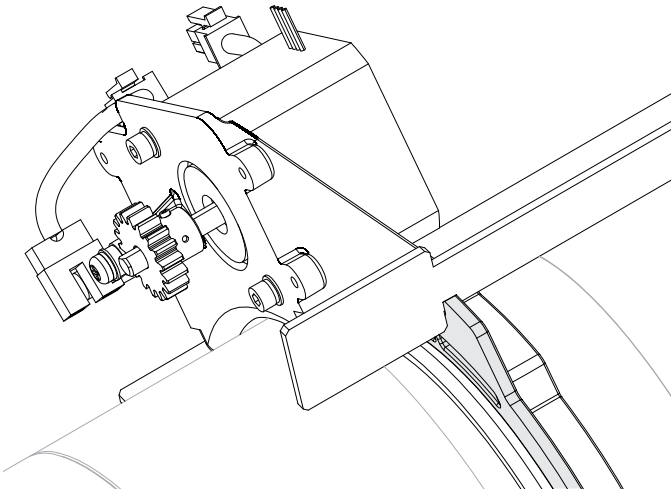

7. Tighten the screw securing the motor clamp (A in the image below).

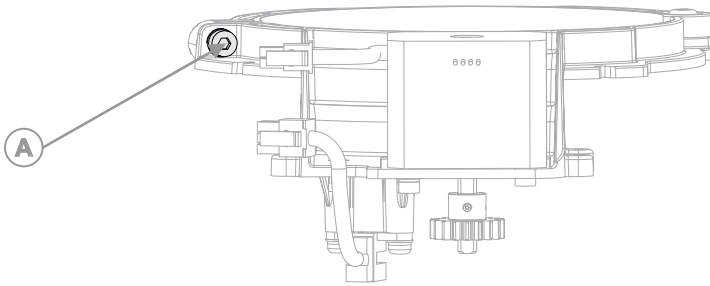

8. Rotate the zoom ring on the lens clockwise until it hits the stop.
To determine the rotation direction, stand at the rear of the lens (motor clamp is on the other side of the lens to you).

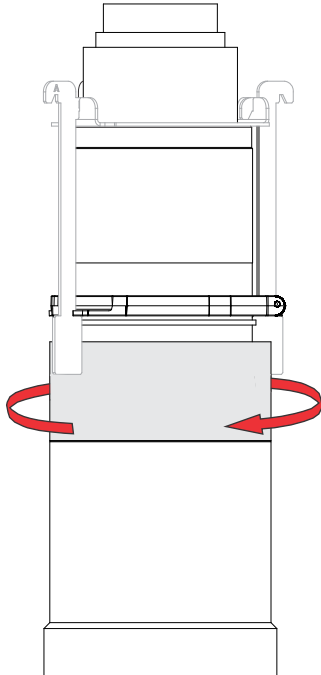

9. Install the adapter ring if required (applicable lenses).
 - 1.8-3.0:1 lens—Small (thin) adapter ring
 - 1.45-2.05, 2.15-3.6, and 1.25-1.83:1 lenses—Large (thick) adapter ring
 - Other lenses—No adapter ring

To install the adapter, place the two adapter rings inside the gear clamp.

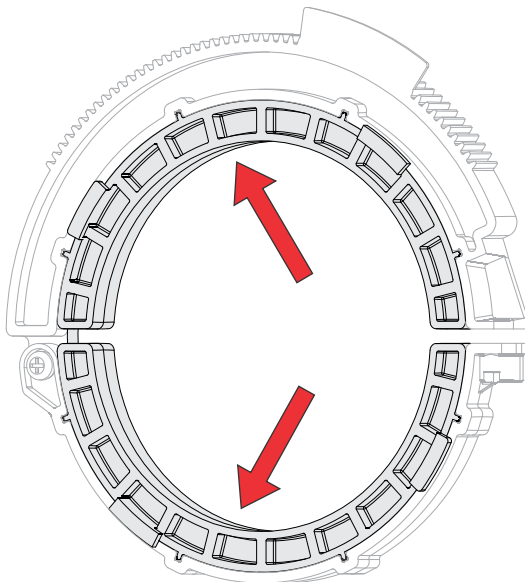

10. Install the two halves of the gear clamp onto the lens, making sure the gear tab (B in the image below) is facing down and goes through the opening in the sensor and when the zoom is at the end stop three to five gear teeth (C in the image below) are on the gear clamp to the right of the motor pinion teeth.

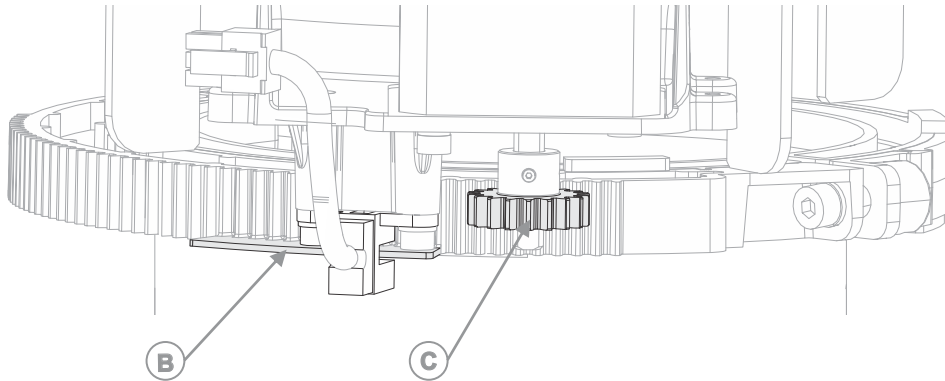

11. Loosely clamp the gear clamp into place until it is placed against the bottom of the position plates.

Note the tab as it will interact with the sensor on the motor clamp; therefore, orientation of the tab matters as it must be on the bottom. The three position plates must be flush and not sitting up (if the gear clamp is pushed too high).

12. Once in position, tighten gear clamp screw (D in the image below).

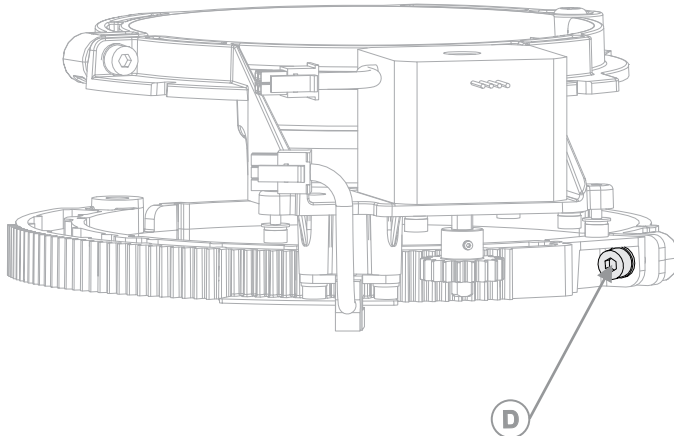

13. Remove the three position plates and alignment ring.
14. Verify you can rotate through the zoom range and the gears are always engaged throughout the rotation (especially for the hard stops at each end).
If the gears are not engaged throughout the rotation, rotate the gear clamp until the gears are engaged throughout.
15. If the gear is not engaged fully, adjust the zoom gear motor position by loosening the screw shown below.

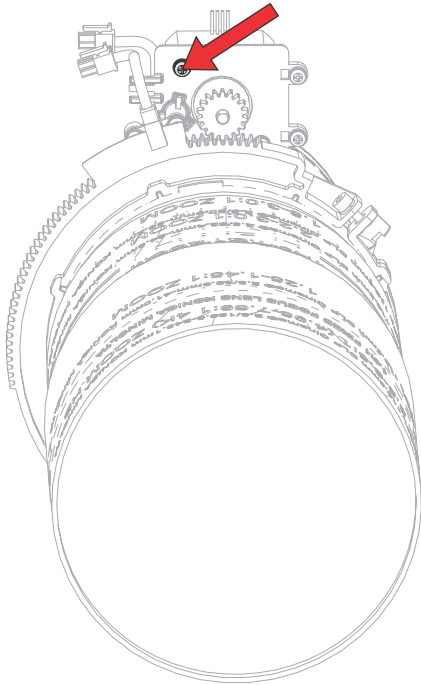

16. Rotate the zoom motor until the gear is fully engaged.
17. Tighten the screw shown in the image below.

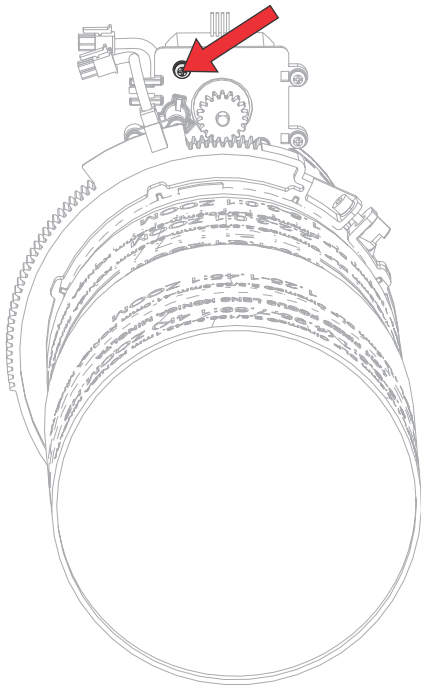

18. Install the zoom motor cover:
 - a) Rotate the zoom sensor harness to the rear of the lens.
 - b) Place the zoom motor cover over top of zoom motor and route the harness through the gap between the cover and the motor clamp so you do not crimp it.

- c) Install the three screws (removed in step 1) to secure the cover.

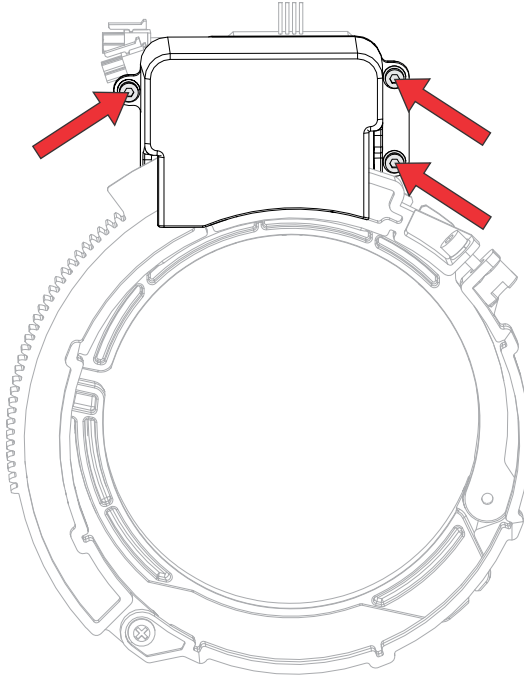

19. Install the lens in the projector.
20. Add the zoom motor and sensor harnesses to the lensmount of the projector.
21. Run an intelligent lens system (ILS) calibration.
Refer to the projector model's Service guide for information on how to perform an ILS calibration.

Replacing the motorized control assembly bottom enclosure

Follow these steps to replace the motorized control assembly (MCA) bottom enclosure.

The following projectors or accessories must use the new bottom enclosure for the motor control assembly:

- -01 and -02 Motor Upgrade kits (P/N: 127-102104-01 and 127-102104-02)
- CP2220 with motorized lens mount
- CP2230 with motorized lens mount
- CP4420
- CP4230
- E3LH
- CP42LH

All other projector models and the -03 Motor Upgrade kits (P/N: 127-102104-03) do not need to replace the bottom enclosure on the motor control assembly.

1. Remove the two M4 screws and washers securing the metal safety cover for the focus motor.

2. Disconnect all the harnesses.
3. Remove the motor control assembly from the lens mount by loosening the two screws and shifting the assembly up and pulling it away from the projector.

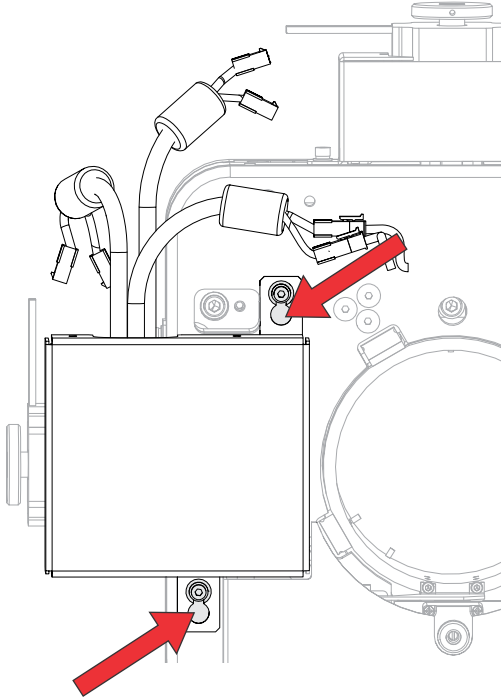

4. Remove the four screws securing the top cover of the motor control assembly and remove the cover.

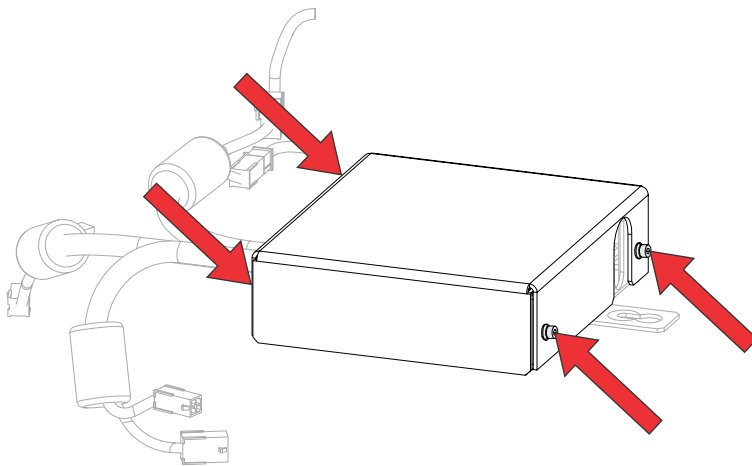

5. Loosen the screw securing the board to the bottom enclosure.

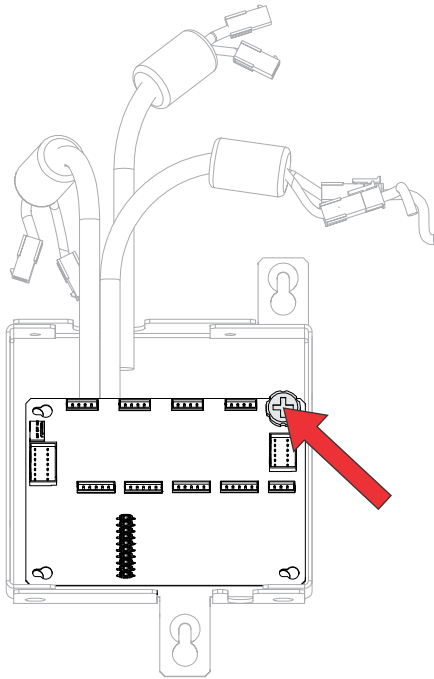

6. Slide the board with all the harnesses still connected to the left and pull it up.
7. Put the board into the new bottom enclosure, sliding it down and to the right.
8. Tighten the screw (from step 5) to secure the board to the bottom enclosure.
9. Ensure the grommets are in the slots.
10. Place the top cover on the MCA and install the four screws (removed in step 3) to secure the cover.
11. Install the MCA assembly by sliding the keyslots over the screws on the lens mount.
12. Connect harnesses from each stepper motor to their designated inline connector from the MCA.

Harnesses and motors are color coded (with a label) for ease of connection with motor control harnesses. When installing make sure of the following:

- | | | |
|---|--------------|------------|
| A | White label | Horizontal |
| B | Red label | Vertical |
| C | Green label | Zoom |
| D | Yellow label | Focus |

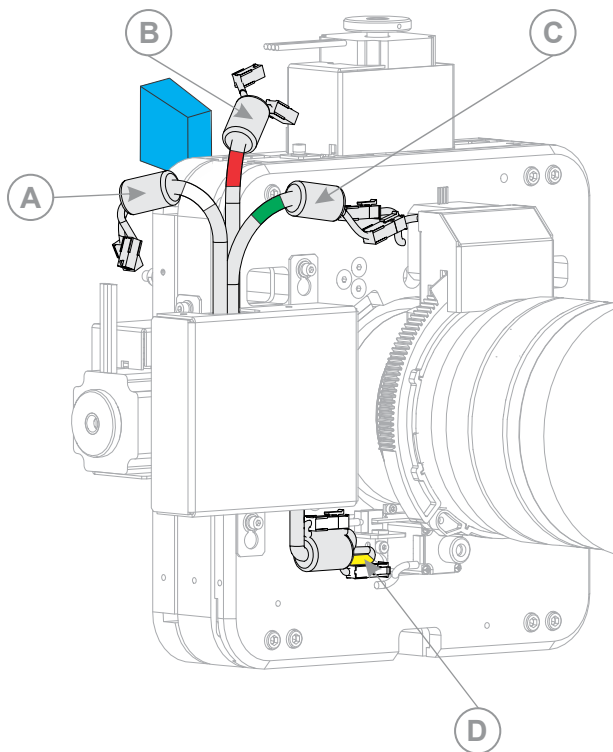

13. Connect the power harness from the MCA to the connector port on the projector (blue component in the image in step 11).
14. Re-install the focus motor metal safety cover using two M4 screws and washers.

Technical support

Technical support for Christie Cinema products is available at:

- Support.cinema@christiedigital.com
- +1-877-334-4267
- Christie Professional Services: +1-800-550-3061 or NOC@christiedigital.com