



Installation and Setup Guide

020-002066-05

# Christie CIC 1DLP Camera

**CHRISTIE®**

## NOTICES

### COPYRIGHT AND TRADEMARKS

Copyright ©2026 Christie Digital Systems USA Inc. All rights reserved.

All brand names and product names are trademarks, registered trademarks or trade names of their respective holders.

### GENERAL

Every effort has been made to ensure accuracy, however in some cases changes in the products or availability could occur which may not be reflected in this document. Christie reserves the right to make changes to specifications at any time without notice. Performance specifications are typical, but may vary depending on conditions beyond Christie's control such as maintenance of the product in proper working conditions. Performance specifications are based on information available at the time of printing. Christie makes no warranty of any kind with regard to this material, including, but not limited to, implied warranties of fitness for a particular purpose. Christie will not be liable for errors contained herein or for incidental or consequential damages in connection with the performance or use of this material. Our centers of excellence for manufacturing in Kitchener, Ontario, Canada and in Shenzhen, China are ISO 9001:2015 Quality Management System-certified.

Christie is committed to making our documents free from language bias; however, we are not responsible for the language used on any linked or third-party documentation.

For the most current technical documentation and office contact information, visit [www.christiedigital.com](http://www.christiedigital.com).

### WARRANTY

Products are warranted under Christie's standard limited warranty, the details of which are available at <https://www.christiedigital.com/help-center/warranties/> or by contacting your Christie dealer or Christie.

### PREVENTATIVE MAINTENANCE

Preventative maintenance is an important part of the continued and proper operation of your product. Failure to perform maintenance as required, and in accordance with the maintenance schedule specified by Christie, voids the warranty. For preventative maintenance schedules, refer to [www.christiedigital.com](http://www.christiedigital.com).

### REGULATORY (if applicable)

The product has been tested and found to comply with the limits for a Class A digital device, pursuant to Part 15 of the FCC Rules. These limits are designed to provide reasonable protection against harmful interference when the product is operated in a commercial environment. The product generates, uses, and can radiate radio frequency energy and, if not installed and used in accordance with the instruction manual, may cause harmful interference to radio communications. Operation of the product in a residential area is likely to cause harmful interference in which case the user will be required to correct the interference at the user's own expense. Changes or modifications not expressly approved by the party responsible for compliance could void the user's authority to operate the equipment.

### CAN ICES-3 (A) / NMB-3 (A)

이 기기는 업무용 (A 급) 으로 전자파적합등록을 한 기기이오니 판매자 또는 사용자는 이점을 주의하시기 바라며, 가정 외의 지역에서 사용하는 것을 목적으로 합니다.

### ENVIRONMENTAL



The product is designed and manufactured with high-quality materials and components that can be recycled and reused. This symbol  means that electrical and electronic equipment, at their end-of-life, should be disposed of separately from regular waste. Please dispose of the product appropriately and according to local regulations. In the European Union, there are separate collection systems for used electrical and electronic products.

If printing this document, consider printing only the pages you need and select the double-sided option.

Please help us to conserve the environment we live in!

### NOTATION

Learn the hazard and information symbols used in the product documentation.



**Danger!** If not avoided, the following could result in death or serious injury.



**Warning!** If not avoided, the following could result in death or serious injury.



**Caution!** If not avoided, the following could result in minor or moderate injury.



**Notice.** If not avoided, the following may result in equipment or property damage.



Information messages provide additional information, emphasize or provide a useful tip.

# Content

- Introduction ..... 4**
  - Safety and warning guidelines ..... 4
  - Product labels ..... 5
  - Product overview..... 5
  - List of components ..... 5
  - Technical support ..... 6
- Installation and setup ..... 7**
  - Physical operating environment ..... 7
  - Power connection ..... 7
  - Physical specifications ..... 7
  - Installing Christie CIC 1DLP Camera..... 8
  - Setup conditions..... 13
- Diagnostics and Control Interface ..... 14**
  - Troubleshooting ..... 14
  - RS232 commands..... 18
- Operation of camera ..... 19**
  - Setting the Wall color automatically..... 19
  - Setting the focus automatically..... 19
  - Setting the wall color uniformity..... 20
  - Auto color matching instructions..... 21
- Regulatory ..... 23**
  - Electro-magnetic compatibility..... 23
    - Emissions..... 23
    - Immunity..... 23
  - Environmental..... 24

# Introduction

This manual is intended for Christie CIC 1DLP Camera which can be installed in below models:

- DWU880-GS, DWU880A-GS, DWU1100-GS, DWU1100A-GS, DWU1400-GS, DWU1400A-GS
- DWU15-HS, DWU15A-HS, DWU19-HS, DWU19A-HS, DWU23-HS, DWU23A-HS
- 4K13-HS, 4K13A-HS, 4K22-HS, 4K22A-HS
- DWU760-iS, DWU760A-iS, DWU860-iS, DWU960-iS, DWU960A-iS, DWU960ST-iS, DWU960STA-iS, 4K860-iS, 4K860A-iS
- DWU2400-JS, DWU2400A-JS, DWU1800-JS, DWU1800A-JS, 4K2100-JS, 4K2100A-JS, 4K1600-LS, 4K1600A-JS
- 4K1400-KS, 4K1400A-KS, 4K1000-KS, 4K1000A-KS

For complete GS Series, HS Series, Inspire Series, JS Series, and KS Series product documentation and technical support, go to [www.christiedigital.com](http://www.christiedigital.com).

## Safety and warning guidelines

Read all safety and warning guidelines before installing or operating the Christie CIC 1DLP Camera. This product must be operated in an environment that meets the operating range specification.



**Warning!** If not avoided, the following could result in death or serious injury.

- Do not expose the product to moisture.
- Do not operate the product without all of its covers in place.
- Do not allow anything to rest on the power cord.
- Always provide proper ventilation for the product to prevent overheating.



**Caution!** If not avoided, the following could result in minor or moderate injury.

- Only Christie qualified technicians are permitted to open product enclosures.
- All procedures must be performed by Christie qualified technicians.
- ELECTRICAL and BURN HAZARD! Use caution when accessing internal components.



**Notice.** If not avoided, the following may result in equipment or property damage.

- SHOCK HAZARD! Only use the AC power sources recommended by Christie for use with the product.
- Do not insert foreign objects or liquids into the product.
- Do not use chemical cleaners to clean the product.
- Do not drop the product.
- Only use cleaning solutions recommended by Christie. All other cleaning solutions may cause product damage and void the warranty.

## Product labels

Learn about the labels that may be used on the product. Labels on your product may be yellow or black and white.

### General hazards

Hazard warnings also apply to accessories once they are installed in a Christie product that is connected to power.

#### Fire and Shock Hazard



To prevent fire or shock hazards, do not expose this product to rain or moisture.  
Do not alter the power plug, overload the power outlet, or use it with extension Cords.  
Do not remove the product enclosure.  
Only Christie qualified technicians are authorized to service the product.

#### Electrical Hazard



Risk of electric shock.  
Do not remove the product enclosure.  
Only Christie qualified technicians are authorized to service the product.

## Product overview

Christie CIC 1DLP Camera is designed for GS Series, HS Series, Inspire Series, JS Series, and KS Series projection systems. It supports Auto Focus (AF), Auto Wall Color (AC), Auto Color Uniformity (ACU), Auto Color Matching (ACM), and Auto Blend functions.

## List of components

The Christie CIC 1DLP Camera comes with all the items listed below. Check to make sure your package is complete.

If anything is missing, contact your dealer.

- Christie CIC 1DLP Camera (quantity 1)
- Bracket (quantity 2)

#### *GS/HS Series projector*

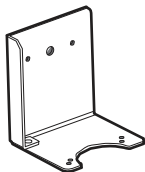

#### *Inspire/JS/KS Series projector*

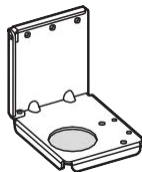

- 1.3 m (4.2 feet) USB-A to USB-B cable (quantity 1)
- M3L8 screw (quantity 4)
- Cable mount (quantity 6)
- Product information label (quantity 1)

## Technical support

Technical support for Christie Enterprise products is available at:

- North and South America: +1-800-221-8025 or [Support.Americas@christiedigital.com](mailto:Support.Americas@christiedigital.com)
- Europe, Middle East, and Africa: +44 (0) 1189 778111 or [Support.EMEA@christiedigital.com](mailto:Support.EMEA@christiedigital.com)
- Asia Pacific ([support.apac@christiedigital.com](mailto:support.apac@christiedigital.com)):
  - China: +86 10 6561 0240 or [tech-supportChina@christiedigital.com](mailto:tech-supportChina@christiedigital.com)
  - India: +91 (80) 6708 9999 or [tech-India@christiedigital.com](mailto:tech-India@christiedigital.com)
  - Japan: 81-3-3599-7481
  - Singapore: +65 6877-8737 or [tech-Singapore@christiedigital.com](mailto:tech-Singapore@christiedigital.com)
  - South Korea: +82 2 702 1601 or [tech-Korea@christiedigital.com](mailto:tech-Korea@christiedigital.com)

# Installation and setup

Learn how to install and connect to the projector.

## Physical operating environment

Provides specifications for the operating environment.

- Ambient temperature (operating): 0 to 50°C (32 to 122°F)
- Humidity (non-condensing): 20% to 80% RH

## Power connection

Connect the USB cable to the projector and use the cable mount to hold cable securely.

## Physical specifications

Learn the dimensions and weight of the **Christie CIC 1DLP Camera** before installation.

- Christie CIC 1DLP Camera (L x W x H): 93 x 84 x 48.5 mm (3.66 x 3.31 x 48.8 inches)
- Shipping size (L x W x H): 425 x 295 x 160 mm (16.73 x 11.61 x 6.3 inches)
- Weight: 0.2 kg (0.44 lbs)
- Shipping weight: 0.5 kg (1.1 lbs)

# Installing Christie CIC 1DLP Camera

To install and connect the Christie CIC 1DLP Camera to the projector, follow these steps:

## For GS/HS Series projector:

1. Align and secure the bracket to the rear side of the camera with the supplied screws.

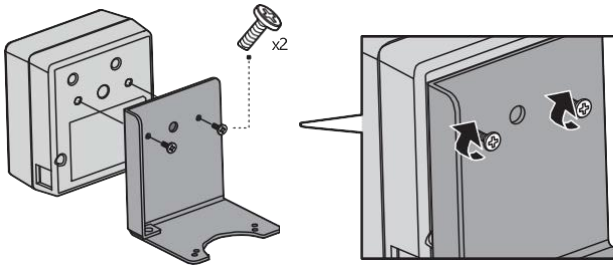

2. Align the holes marked A on the camera bracket with the holes on the bottom of the projector and secure the camera to the projector with the two M3L8 screws.

### GS Series projector

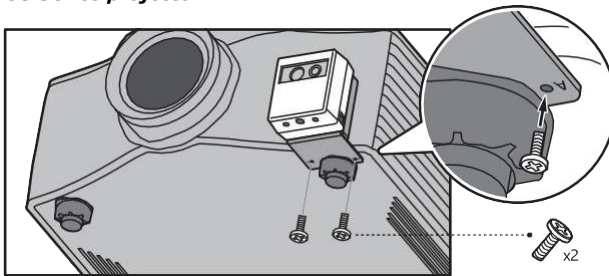

### HS Series projector

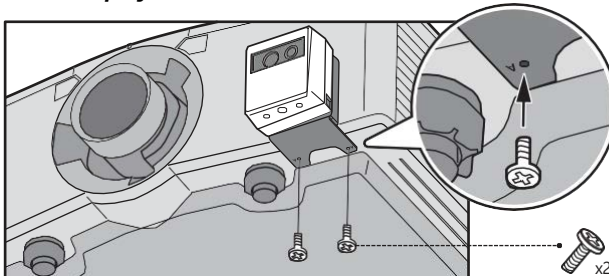

3. Connect the USB-B end of the supplied USB cable to the camera and the USB-A end to the projector.

4. Route and secure the USB cable to the supplied cable mounts.

**GS Series projector**

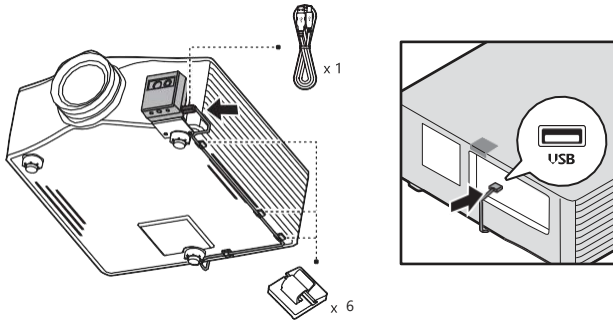

**HS Series projector**

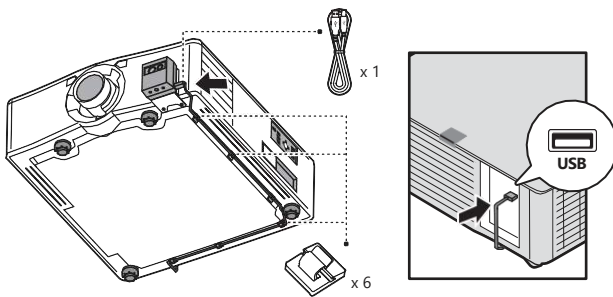

**For Inspire Series projector:**

1. Align and secure the bracket to the rear side of the camera with the supplied screws.

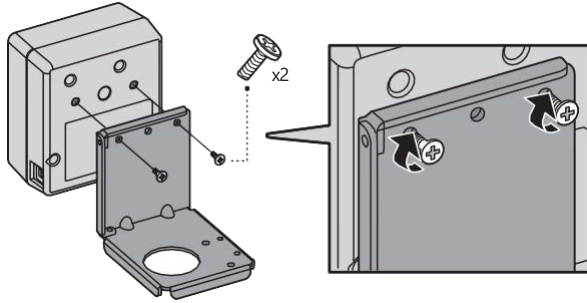

2. Align the holes on the camera bracket with the holes on the bottom of the projector and secure the camera to the projector with the two M3L8 screws.

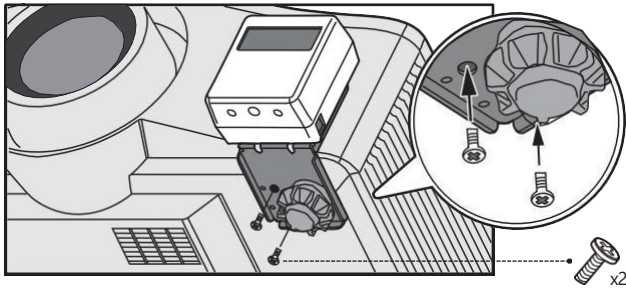

3. Connect the USB-B end of the supplied USB cable to the camera and the USB-A end to the projector.
4. Route and secure the USB cable to the supplied cable mounts.

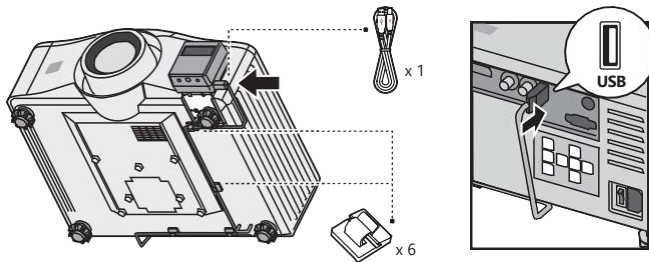

**For JS/KS Series projector:**

1. Align and secure the bracket to the rear side of the camera with the supplied screws.

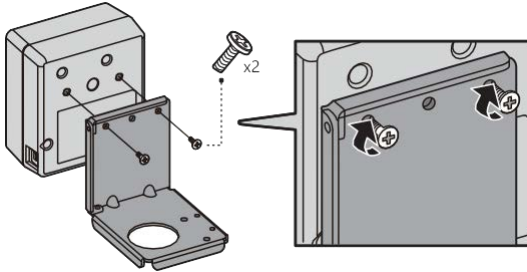

2. Align the holes marked B on the camera bracket with the holes on the bottom of the projector and secure the camera to the projector with the two M3L8 screws.

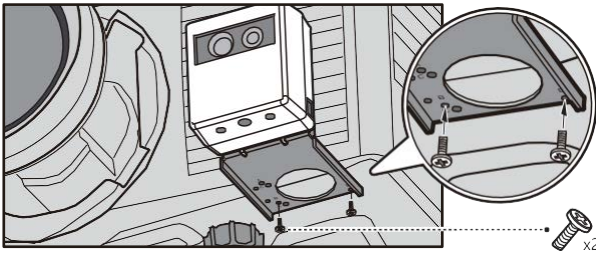
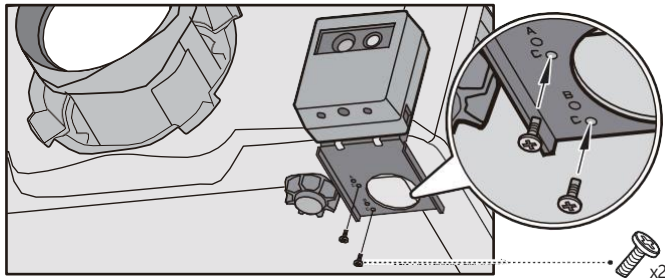
**JS Series projector****KS Series projector**

3. Connect the USB-B end of the supplied USB cable to the camera and the USB-A end to the projector.
4. Route and secure the USB cable to the supplied cable mounts.

**JS Series projector**

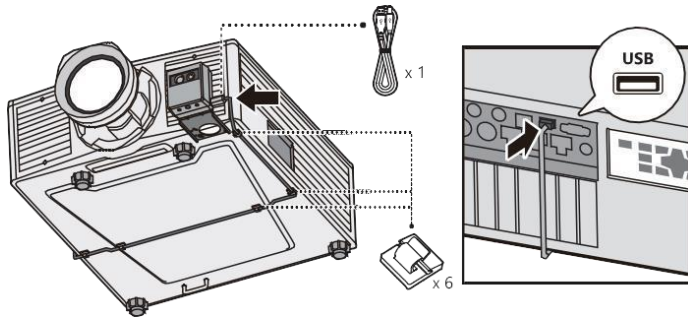

**KS Series projector**

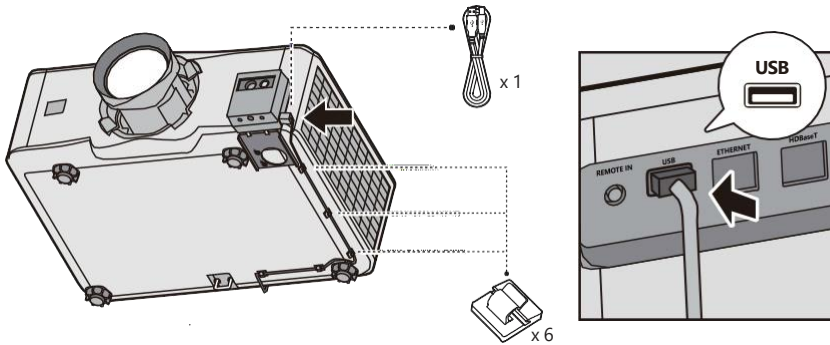

## Setup conditions

Note the following conditions before using the camera function:

- Each projector requires a CIC 1DLP camera.
- Camera function is supported only at the front and ceiling projections as illustrated below:

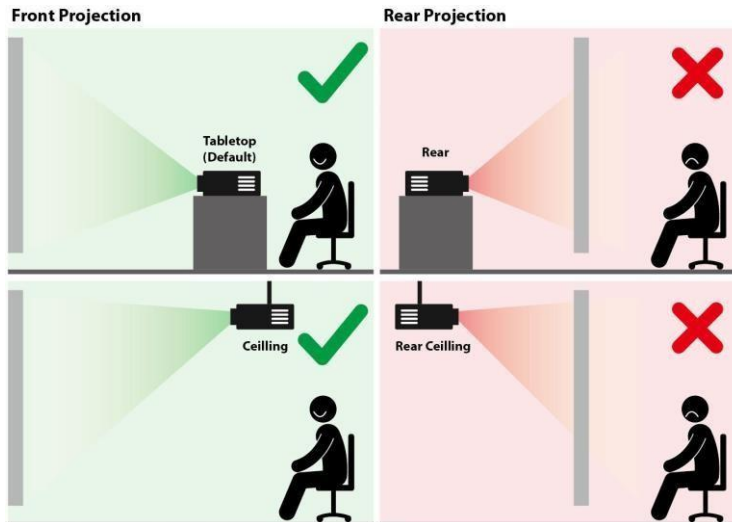

- Camera functions are available for the projection sizes from 304.8 to 762 cm (120 to 300 inches), except for 4K22-HS, 4K22A-HS, **4K2100-JS** and **4K1600-JS** the available projection sizes are from 381 to 762 cm (150 to 300 inches).
- Avoid any obstructions between the camera view and the projected image.
- Avoid using reflective surface and strong light between the camera view and the projected image.
- Camera function is not supported in 3D, 2D high speed, or high frame rate mode.
- The 2.90-5.50 zoom G lens (P/N: 140-107109-XX), 2.0-4.0:1 zoom H lens (P/N: **140-111104-XX**), and 4.0-7.2:1 zoom H lens (P/N: 140-116109-XX) do not support the auto focus function, as the zoom size changes when the auto focus function is applied.
- The 0.36-1 fixed ultra short throw GS Series lens (P/N: 140-133108-XX), 0.38:1 ultra short throw HS Series lens (P/N: 140-142108-XX), 0.37-0.4:1 zero offset GS Series lens (P/N: 140-153100-XX), and 0.34-0.37:1 ultra short throw JS/KS Series lens (P/N: **140-164102-XX**) do not support the camera function.

# Diagnostics and control interface

Learn how to diagnose common issues and communicate with the projector.

## Troubleshooting

Follow these procedures to help to solve issues with the Christie CIC 1DLP Camera.

Error message	Action
<b>Auto focus function errors:</b>	
Please connect the camera	Make sure the Christie CIC 1DLP Camera is connected to the projector and does not disconnect the CIC 1DLP camera from the projector during calibration.
Calibration failed	<ul style="list-style-type: none"> <li>• Ensure the Christie CIC 1DLP Camera is connected to the projector and does not disconnect the Christie CIC 1DLP Camera during calibration.</li> <li>• Christie CIC 1DLP Camera search ROI failure. Make sure no obstructions exist between the Christie CIC 1DLP Camera and the projection image.</li> <li>• Projection size is between 304.8 to 762 cm (120 to 300 inches), except for 4K22-HS and 4K22A-HS, which are from 381 to 762 cm (150 to 300 inches).</li> </ul>
Camera does not support this color wheel speed	Christie CIC 1DLP camera features do not support 3D, 2D high speed, or high frame rate mode.
Image recognition error	<p>Ensure the following:</p> <ul style="list-style-type: none"> <li>• Christie CIC 1DLP Camera is connected to the projector.</li> <li>• No obstructions and strong light between the Christie CIC 1DLP Camera and the projection image.</li> <li>• Projection size is between 304.8 to 762 cm (120 to 300 inches), except for 4K22-HS and 4K22A-HS, which are from 381 to 762 cm (150 to 300 inches).</li> <li>• If the error still persists, the auto focus peak value detection may have failed. Check the lens and motor status.</li> </ul>
Image is overexposed	Lower the projector power level or ensure the projection size is above 304.8 cm (120 inches) or above 381 cm (150 inches) for 4K22-HS and 4K22A-HS.
Image is underexposed	Increase the projector power level or make sure the projection size is below 762 cm (300 inches).
Image capture error	Make sure the Christie CIC 1DLP Camera is connected to the projector.
Camera is busy	Confirm if any other applications are using the Christie CIC 1DLP Camera.
Operation does not support lens lock	Ensure the CIC 1DLP Camera is connected to the projector and do not disconnect the Christie CIC 1DLP Camera during calibration.

<b>Error message</b>	<b>Action</b>
<b>Auto wall color errors:</b>	
Image recognition error	<p>Ensure the following:</p> <ul style="list-style-type: none"> <li>• Christie CIC 1DLP Camera is connected to the projector.</li> <li>• No obstructions and strong light between the Christie CIC 1DLP Camera and the projection image.</li> <li>• Projection size is between 304.8 to 762 cm (120 to 300 inches), except for 4K22-HS and 4K22A-HS are from 381 to 762 cm (150 to 300 inches).</li> </ul>
Camera does not support this color wheel speed	Christie CIC 1DLP Camera features do not support 3D, 2D high speed, or high frame rate mode.
Please connect the camera	Ensure the CIC 1DLP Camera is connected to the projector.
Camera is busy	Confirm if any other applications are using the Christie CIC 1DLP Camera.
Calibration failed	Make sure the Christie CIC 1DLP Camera is connected to the projector and calibrate again.
Please disable auto source before calibration	Disable the auto source function.
Image is overexposed	Lower the projector power level or ensure the projection size is above 304.8 cm (120 inches) or above 381 cm (150 inches) for 4K22-HS and 4K22A-HS.
Image is underexposed	Increase the projector power level or ensure the projection size is below 762 cm (300 inches).
Image capture error	Make sure the Christie CIC 1DLP Camera is connected to the projector.
<b>Auto color uniformity (ACU) errors:</b>	
Please connect the camera	Make sure the Christie CIC 1DLP Camera is connected to the projector and do not disconnect the Christie CIC 1DLP Camera from the projector during calibration.
System communication error	This error occurs because of the system DBUS error. Reboot the projector and calibrate again.
Calibration failed	Make sure the Christie CIC 1DLP Camera is connected to the projector and calibrate again.
Image recognition error	<p>Ensure the following:</p> <ul style="list-style-type: none"> <li>• Christie CIC 1DLP Camera is connected to the projector.</li> <li>• Christie CIC 1DLP Camera search ROI failure. No obstructions and strong light between the CIC 1DLP camera and the projection image.</li> <li>• Projection size is between 304.8 to 762 cm (120 to 300 inches), except for 4K22-HS and 4K22A-HS, which are from 381 to 762 cm (150 to 300 inches).</li> <li>• Avoid projection on the surface with deep color or wall with multiple colors.</li> </ul>
Image capture error	Make sure the Christie CIC 1DLP Camera is connected to the projector.
Camera is busy	Confirm if any other applications are using the Christie CIC 1DLP Camera.
Camera does not support this color wheel speed	Christie CIC 1DLP Camera features do not support 3D, 2D high speed, or high frame rate mode.
Operation does not support this gamma	Make sure the projector gamma is not set to blackboard, DICOM, or HDR.

<b>Error message</b>	<b>Action</b>
Out of calibration range	Ensure the following: <ul style="list-style-type: none"> <li>• No obstructions between the Christie CIC 1DLP Camera and the projection image.</li> <li>• Avoid projection on the surface with deep color or wall with multiple colors. If possible, project on the white wall in a dark environment.</li> <li>• If the error still persists, contact the service provider.</li> </ul>
Image is overexposed	Lower the projector power level or ensure the projection size is above 304.8 cm (120 inches) or above 381 cm (150 inches) for 4K22-HS and 4K22A-HS.
Image is underexposed	Increase the projector power level or ensure the projection size is below 762 cm (300 inches).
Please enable the function before calibration	Enable the function before calibration.
Target recognition error	Make sure no obstructions exist between the Christie CIC 1DLP Camera and the projection image.
Operation is not supported	Reset ACU and try again.
<b>Auto color matching errors:</b>	
Auto function fail	Check the auto color matching function error code.
Projector state is busy	Make sure all projectors are idle.
Projector state is invalid	Ensure the following: <ul style="list-style-type: none"> <li>• All projectors are powered on.</li> <li>• All projectors are idle.</li> </ul>
Projector connection fail	Make sure the IP addresses and network connections of all projectors are valid.
Projector remote connection fail	Verify the network connection of all projectors and make sure they are connected to the network.
Projector inner connection fail	Projector system error. Ensure the following: <ul style="list-style-type: none"> <li>• All projectors support auto color matching. If all projectors support auto color matching, wait for two minutes and try again.</li> </ul>
Command timeout	Make sure the IP addresses and network connections of all projectors are valid.
Command parameter error	Make sure JSON command parameters are correct.
Command slave not support	Ensure the following: <ul style="list-style-type: none"> <li>• All projectors support auto color matching.</li> <li>• All projectors are idle.</li> </ul>
Function is not running	The main projector is not processing the auto color matching function.
Command not support	Make sure the main projector supports the auto color matching function or any other requested command.
Result: Fail	Ensure the following: <ul style="list-style-type: none"> <li>• All projectors are the same model.</li> <li>• All projectors are idle.</li> </ul>

<b>Error message</b>	<b>Action</b>
Camera search ROI fail	Make sure no obstructions between the Christie CIC 1DLP Camera and the projection image.
Color wheel speed not support	Christie CIC 1DLP Camera features do not support 3D, 2D high speed, or high frame rate mode.
Camera is busy	Confirm if any other applications are using the Christie CIC 1DLP Camera.
Camera setting fail	Make sure the Christie CIC 1DLP Camera is connected to the projector and does not disconnect the Christie CIC 1DLP Camera from the projector during calibration.
Camera overexposure	Lower the projector power level or make sure the projection size is above 304.8 cm (120 inches) or above 381 cm (150 inches) for 4K22-HS and 4K22A-HS.
Set camera gain fail	This error occurs when auto tuning the Christie CIC 1DLP Camera fails. Make sure the Christie CIC 1DLP Camera is connected to the projector and try again.
Camera underexposure	Increase the projector power level or make sure the projection size is below 762 cm (300 inches).
Tuning over limit	This error indicates out of calibration range. Ensure the following: <ul style="list-style-type: none"> <li>• No obstructions between the Christie CIC 1DLP Camera and the projection image.</li> <li>• Avoid projection on the surface with deep color or wall with multiple colors. If possible, project on the white wall in a dark environment.</li> <li>• If the error still persists, contact the service provider.</li> </ul>
Connect camera fail	Make sure the Christie CIC 1DLP Camera is connected to the projector.
Init camera fail	Make sure the Christie CIC 1DLP Camera is connected to the projector.
USER_ABORT	The user has terminated the auto color matching process.

## RS232 commands

Use the following RS232 commands to control the Christie CIC 1DLP Camera:

Function	Command	Response	Value definition
Get camera status	(CST?)	CST!ab	00 = Camera disconnected
			01 = Camera supported
Do Auto Focus	(ATF1)	—	—
Get Auto Focus status	(ATF?)	ATF!ab	00 = Processing (recommended time out 330 seconds)
			01 = Adjustment success
			02 to n = Auto Focus error code
Do Auto Color	(ATF1)	—	—
Get Auto Color status	(ATW?)	ATW!ab	00 = Processing (recommended time out 330 seconds)
			01 = Adjustment success
			02 to n = Auto Wall error code
Enable Auto Color Uniformity	(ACEa)	—	0 (Off), 1 (On)
Do Auto Color Uniformity	(ACC1)	—	—
Select Auto Color Uniformity target	(ACTxy)	—	x = 1 to 9
		—	y = 1 to 7
Get Auto Color Uniformity status	(ACC?)	ACC!ab	00 = Processing (recommended time out 330 seconds)
			01 = Adjustment success
			02 to n = Auto Color Uniformity error code
Reset Auto Color Uniformity	(ACR1)	—	—

# Operation of camera

All settings for the camera are done in the Image settings menu of the projector. The screen size must be between 3 to 7.6 m (120 to 300 inches) diagonal measurement.

## Setting the wall color automatically

Automatically adjust image colors to match your wall color.

1. Select **MENU**.
2. Select **Input switching** > **Input key** > **Change sources** or **List all sources**.
3. Select **Image settings** > **Color matching** > **Auto Wall Color**.
4. Select **ENTER**.
5. When the Run Auto wall color message appears, select **OK**.

The displayed image should alternately flash with white, cyan, yellow and magenta colors. At the end of the color calibration the projector should prompt with a selection of **CURRENT** or **PREVIOUS**.

- To select the current setting (as adjusted by camera), select **CURRENT**.
- If the previous setting is required, select **PREVIOUS**.

## Setting the focus automatically

Automatically adjust the lens to achieve optimal image focus.



Boresight needs to be done prior to adjustment.

1. Select **MENU**.
2. Select **IMAGE SETTINGS** > **Auto Image Settings** > **Auto focus**.
3. Select **ENTER**.
4. When the Run Auto focus message appears, select **OK**.

The displayed image should alternately flash between a white and checkerboard pattern. The lens should focus automatically during this time. At the completion of the setting, the Calibrated message appears.

## Setting the wall color uniformity

Correct uneven color across the screen for a more uniform projected image.

1. Select **MENU**.
2. Select **IMAGE SETTINGS > Auto Image Settings > Auto color uniformity**.
3. Select the Target selection.  
A display appears with boxes showing in a grid pattern (representing 1 to 63 positions).

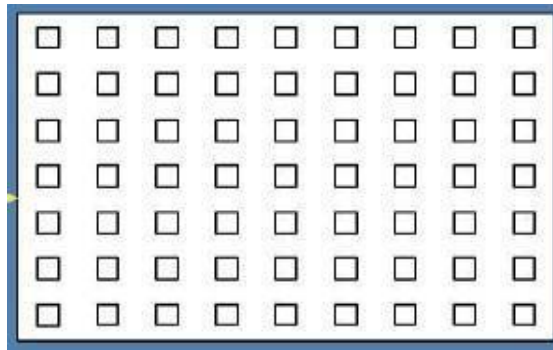

- a. If required, use your cursor to move the outlined box to another targeted area of the screen that needs uniformity adjustment.
- b. Alternatively, leave the box at the center position to perform a centered adjustment.
- c. Select the Calibration setting and select **ENTER**.
- d. When the Run auto color uniformity message appears, select **OK**.

The displayed image should alternately flash with various levels of white and checkerboard patterns. At the end of the color calibration the projector should prompt with a selection **CURRENT** or **PREVIOUS**.

- To select the current setting (as adjusted by camera), select **CURRENT**.
- If the previous setting is required, select **PREVIOUS**.

# Auto color matching instructions

Automatically align color output for consistent and accurate image reproduction. The required equipment is required to perform auto color matching.

- 1x PC
  - Christie Mystique™ Lite free software
  - 2-3x CIC-compatible projectors (same model)
  - 1x CIC 1DLP Camera per projector
  - Ethernet cables
  - Network switch
1. Power on the projector and set up the network configuration.
    - a. Connect and power on all projectors.
    - b. Set each projector's IP address to the same subnet.
    - c. Menu structures may vary by model.
    - d. Navigate to **Menu > Configuration > Communications > LAN** and configure the following:
      - **DHCP**—Enable or disable DHCP to automatically acquire network settings.
      - **IP Address**—Assign the appropriate network IP address.
      - **Subnet Mask**—Set the network subnet mask.
    - e. To confirm the settings, select **Apply**.
  2. Configure the PC network.
    - a. Make sure the PC is set to an IP address within the same subnet as the projectors.
    - b. Connect the projectors and PC to a network switch.
    - c. Verify successful network communication.
  3. Connect and position the camera.
    - a. Connect a Christie CIC 1DLP Camera to each projector using the supplied USB cable.
    - b. Make sure the camera captures the entire projector image for optimal calibration.
    - c. Calibrate the projectors minimal stray light in the room for optimal calibration.

4. Set up the software and perform calibration.
  - a. Launch Christie Mystique™ Lite software.
  - b. To detect cameras and projectors, select **Find More** from the menu.
  - c. Select the three horizontal lines to access the **Color Match** menu.
5. To perform calibration, select **Color Match**.

The projectors cycle through various colored test patterns. The Christie CIC 1DLP Camera measures and adjusts color output accordingly.
6. Optionally, complete the final adjustments if further manual calibration is needed.
  - a. To adjust brightness select **Menu > Light Source**
  - b. To fine-tune color settings. Select **Menu > Image Settings > Color Matching > HSG Adjustment**.

# Regulatory

This product conforms to the following regulations related to product safety, environmental requirements and electromagnetic compatibility (EMC).

## Electro-magnetic compatibility

### Emissions

- FCC CFR Title 47, Part 15, Subpart B, Section 15.107 and 15.109
- ICES-003 Issue 7: 2020 Class A
- VCCI-CISPR 32: 2016 / J55032(H29) Class A
- EN55032: 2015+A11: 2020 - Information Technology Equipment Radio Disturbance Characteristics – Limits and Methods of Measurements
- IEC 61000-3-2 / EN61000-3-2 - Limits for Harmonic Current Emissions
- IEC 61000-3-3 / EN61000-3-3 - Limitations of Voltage fluctuations and flicker in low-voltage supply systems.
- KS C 9832: 2019 - Electromagnetic interference prevention test for multimedia equipment

### Immunity

- EN 55035 : 2017+A11: 2020 - EMC Requirements - Information Technology Equipment – Immunity Characteristics – Limits and Methods of Measurements
- KS C 9835: 2019 - Electromagnetic wave immunity test for multimedia devices

## Environmental

- EU Directive (2011/65/EU) on the restriction of the uses of certain hazardous substances (RoHS) in electrical and electronic equipment and the applicable official amendment(s)
- EU Directive (2012/19/EU) on waste and electrical and electronic equipment (WEEE) and the applicable official amendment(s)
- Regulation (EC) No 1907/2006 concerning the Registration, Evaluation, Authorization and Restriction of Chemicals (REACH) and the applicable official amendment(s)
- China Ministry of Information Industry Order No.39 (02/2006) on the control of pollution caused by electronic information products, hazardous substances concentration limits (SJ/T11363-2006), and the applicable product marking requirement (SJ/T11364-2006)