

# User Manual

020-102150-03

## CP2208-LP



## NOTICES

### COPYRIGHT AND TRADEMARKS

Copyright © 2017 Christie Digital Systems USA Inc. All rights reserved.

All brand names and product names are trademarks, registered trademarks or trade names of their respective holders.

### GENERAL

Every effort has been made to ensure accuracy, however in some cases changes in the products or availability could occur which may not be reflected in this document. Christie reserves the right to make changes to specifications at any time without notice. Performance specifications are typical, but may vary depending on conditions beyond Christie's control such as maintenance of the product in proper working conditions. Performance specifications are based on information available at the time of printing. Christie makes no warranty of any kind with regard to this material, including, but not limited to, implied warranties of fitness for a particular purpose. Christie will not be liable for errors contained herein or for incidental or consequential damages in connection with the performance or use of this material. Canadian manufacturing facility is ISO 9001 and 14001 certified.

### WARRANTY

Products are warranted under Christie's standard limited warranty, the complete details of which are available by contacting your Christie dealer or Christie. In addition to the other limitations that may be specified in Christie's standard limited warranty and, to the extent relevant or applicable to your product, the warranty does not cover:

- a. Problems or damage occurring during shipment, in either direction.
- b. Problems or damage caused by combination of a product with non-Christie equipment, such as distribution systems, cameras, DVD players, etc., or use of a product with any non-Christie interface device.
- c. Problems or damage caused by misuse, improper power source, accident, fire, flood, lightning, earthquake, or other natural disaster.
- d. Problems or damage caused by improper installation/alignment, or by equipment modification, if by other than Christie service personnel or a Christie authorized repair service provider.
- e. Problems or damage caused by use of a product on a motion platform or other movable device where such product has not been designed, modified or approved by Christie for such use.
- f. Except where the product is designed for outdoor use, problems or damage caused by use of the product outdoors unless such product is protected from precipitation or other adverse weather or environmental conditions and the ambient temperature is within the recommended ambient temperature set forth in the specifications for such product.
- g. Defects caused by normal wear and tear or otherwise due to normal aging of a product.

The warranty does not apply to any product where the serial number has been removed or obliterated. The warranty also does not apply to any product sold by a reseller to an end user outside of the country where the reseller is located unless (i) Christie has an office in the country where the end user is located or (ii) the required international warranty fee has been paid.

The warranty does not obligate Christie to provide any on site warranty service at the product site location.

### PREVENTATIVE MAINTENANCE

Preventative maintenance is an important part of the continued and proper operation of your product. Failure to perform maintenance as required, and in accordance with the maintenance schedule specified by Christie, will void the warranty. For preventative maintenance schedules, refer to [www.christiedigital.com](http://www.christiedigital.com).

### REGULATORY

The product has been tested and found to comply with the limits for a Class A digital device, pursuant to Part 15 of the FCC Rules. These limits are designed to provide reasonable protection against harmful interference when the product is operated in a commercial environment. The product generates, uses, and can radiate radio frequency energy and, if not installed and used in accordance with the instruction manual, may cause harmful interference to radio communications. Operation of the product in a residential area is likely to cause harmful interference in which case the user will be required to correct the interference at the user's own expense.

CAN ICES-3 (A) / NMB-3 (A)

이 기기는 업무용(A급)으로 전자파적합등록을 한 기기이오니 판매자 또는 사용자는 이점을 주의하시기 바라며, 가정 외의 지역에서 사용하는 것을 목적으로 합니다.

### ENVIRONMENTAL

The product is designed and manufactured with high-quality materials and components that can be recycled and reused. This symbol  means that electrical and electronic equipment, at their end-of-life, should be disposed of separately from regular waste. Please dispose of the product appropriately and according to local regulations. In the European Union, there are separate collection systems for used electrical and electronic products. Please help us to conserve the environment we live in!

# Content

<b>Safety precautions.</b> . . . . .	<b>8</b>
Product labels. . . . .	8
General hazards. . . . .	8
Mandatory action. . . . .	9
Electrical labels. . . . .	9
Additional hazard labels. . . . .	9
Laser labels. . . . .	9
Important safeguards. . . . .	10
General safety precautions. . . . .	10
AC/power precautions. . . . .	11
Light intensity hazard distance. . . . .	11
<b>Introduction.</b> . . . . .	<b>14</b>
Projector components (front). . . . .	14
Projector components (rear). . . . .	15
<b>Accessing the projector and running diagnostics.</b> . . . . .	<b>16</b>
The touch panel controller. . . . .	16
Turning the projector on. . . . .	18
Logging on to the projector. . . . .	18
Viewing the status of projector components. . . . .	18
Running the projector interrogator. . . . .	19
Retrieving system logs. . . . .	19
Running a server test. . . . .	20
Responding to alarms. . . . .	20
Turning the projector off. . . . .	20
<b>Managing the Digital Light Processing.</b> . . . . .	<b>21</b>
Resetting the Digital Light Processing. . . . .	21
Running a Digital Light Processing self test. . . . .	21
Downloading an integrated cinema processor certificate. . . . .	22
Disabling the integrated cinema processor signature test. . . . .	22
<b>Managing the light source information.</b> . . . . .	<b>23</b>
Creating a new light source file. . . . .	23

Modifying an existing light source file. . . . .	24
Enabling or disabling LiteLOC on a light source file. . . . .	24
Adjusting light source power. . . . .	24
Verifying the light source sensor readings. . . . .	25
<b>Working with channels. . . . .</b>	<b>26</b>
Creating a new channel. . . . .	26
Activating a channel. . . . .	29
Restoring default channel settings. . . . .	29
Changing the channel icon. . . . .	29
Adding or removing preferred channels. . . . .	30
<b>Managing projector setting files. . . . .</b>	<b>31</b>
Creating a source file. . . . .	31
Modifying a source file. . . . .	31
Creating a screen file. . . . .	32
Modifying a screen file. . . . .	32
Creating a measured color gamut data file. . . . .	32
Modifying a measured color gamut data file. . . . .	33
Creating a target color gamut data file. . . . .	33
Modifying a target color gamut data file. . . . .	33
Creating a new intelligent lens system file. . . . .	34
Editing an existing intelligent lens system file. . . . .	34
Enabling automatic intelligent lens system adjustments on a channel. . . . .	34
Resetting intelligent lens system file settings. . . . .	35
Adding a lens serial number. . . . .	35
Enabling an automatic intelligent lens system on a lens. . . . .	35
Resetting the lens position on projector startup. . . . .	35
Completing a full lens calibration. . . . .	36
Resetting the intelligent lens system and the lens position. . . . .	36
<b>Scheduling events. . . . .</b>	<b>37</b>
Scheduling the projector to turn on or off. . . . .	37
Editing a scheduled event. . . . .	37
Deleting a scheduled event. . . . .	38
Deleting all scheduled events. . . . .	38
Turning off the scheduler. . . . .	38
<b>Viewing and modifying projector settings. . . . .</b>	<b>39</b>

Setting projector and touch panel controller preferences. . . . . 39

Adjusting projector time settings. . . . . 40

Adding or modifying projector communication settings. . . . . 40

Adding a network device. . . . . 41

Accessing a network device. . . . . 41

Calibrating the internal light meter. . . . . 41

Viewing processes and programs running on the projector. . . . . 41

Viewing local or remote computer settings. . . . . 42

Viewing the files on the projector. . . . . 42

Viewing and modifying network connections. . . . . 42

Viewing projector information. . . . . 42

**Managing user accounts. . . . . 43**

    Interpreting user access permissions. . . . . 43

    Adding a user account. . . . . 43

    Changing a user account password or permissions. . . . . 44

    Deleting a user account. . . . . 44

**Backing up, restoring, and upgrading projector files. . . . . 45**

    Adding an upgrade file. . . . . 45

    Removing an upgrade file. . . . . 45

    Installing an upgrade file. . . . . 45

    Backing up projector settings and information. . . . . 46

    Restoring a file. . . . . 46

    Restoring factory default settings. . . . . 47

    Moving files to the projector. . . . . 47

    Deleting projector files. . . . . 47

**Test patterns. . . . . 48**

    Adding or removing preferred test patterns. . . . . 48

    Turning a test pattern on or off. . . . . 48

    Displaying a full screen test pattern. . . . . 48

**Viewing 3D content. . . . . 49**

    Display requirements. . . . . 49

    3D sync terminal pin map. . . . . 49

    Setting up hardware. . . . . 51

    Creating a high frame rate 3D file. . . . . 51

    Editing the default 3D light file. . . . . 52

Defining a measured color gamut data file. . . . .	52
Editing the 3D flat 1998 x 1080 channel. . . . .	53
Editing the 3D scope 2048 x 858 channel. . . . .	53
Displaying 3D diagnostic test patterns. . . . .	54
Verifying 3D cinema content. . . . .	55
Troubleshooting 3D. . . . .	55
Reversed 3D effect (Pseudo 3D). . . . .	55
Image is too dark. . . . .	55
No 3D effect. . . . .	56
Ghosting / cross-talk. . . . .	56
Motion artifacts. . . . .	56
Disturbing flashing in one eye. . . . .	56
<b>Troubleshooting. . . . .</b>	<b>57</b>
Projector functionality. . . . .	57
Projector does not turn on. . . . .	57
Cannot establish communication with projector. . . . .	57
Display issues. . . . .	58
Flicker, shadows, or dimness. . . . .	58
Blank screen with no display of cinema image. . . . .	58
Severe motion artifacts. . . . .	58
Image is vertically stretched or squeezed. . . . .	58
Inaccurate display colors. . . . .	59
Display is not rectangular. . . . .	59
Display is noisy. . . . .	59
Display has suddenly frozen. . . . .	59
Projector does not display alternate content. . . . .	60
Display is unstable. . . . .	60
Portions of the display are cut off. . . . .	60
Inconsistent picture quality. . . . .	60
Touch panel controller issues. . . . .	61
Touch panel controller fails to initialize. . . . .	61
Button presses on the touch panel controller are not registering correctly. . . . .	61
<b>Specifications. . . . .</b>	<b>62</b>
Physical specifications. . . . .	62
Power specifications. . . . .	62
Environmental specifications. . . . .	63
Display specifications. . . . .	63

---

Control signal compatibility. . . . .	64
Touch panel controller specifications. . . . .	65
Accessories. . . . .	65
Regulatory. . . . .	66
Safety. . . . .	66
Electro-magnetic compatibility. . . . .	66
Environmental. . . . .	66

# Safety precautions

Learn about the safety precautions related to the Christie CP2208-LP projector.

## Product labels

Learn about the labels that may be used on the product. Labels on your product may be yellow or black and white.

### General hazards



General hazard.



Electric shock hazard. To avoid personal injury, disconnect all power sources before performing maintenance or service.



Electrocution hazard. To avoid personal injury, always disconnect all power sources before performing maintenance or service procedures.



Hot surface hazard. To avoid personal injury, allow the product to cool for the recommended cool down time before performing maintenance or service.



Pinch hazard. To avoid personal injury, keep hands clear and loose clothing tied back.



Fan hazard. To avoid personal injury, keep hands clear and loose clothing tied back. Always disconnect all power sources before performing maintenance or service procedures.



Voltage hazard. To avoid personal injury, always disconnect all power sources before performing maintenance or service procedures.



Not for household use.



## Mandatory action



Disconnect all power sources before performing maintenance or service procedures.



Consult the user manual.



Consult the service manual.

## Electrical labels



Indicates the presence of a protective earth ground.



Indicates the presence of an earth ground.

## Additional hazard labels

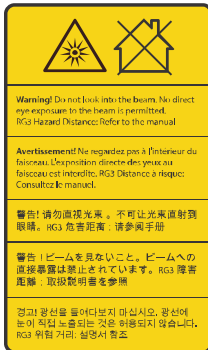

Indicates a light hazard. Do not look directly into the lens. The extreme high brightness can cause permanent eye damage. RG3 IEC 62471-5:2015

## Laser labels

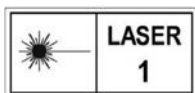

CLASS 1 LASER PRODUCT IEC 60825-1



FDA laser variance (US projectors only)

## Important safeguards

To prevent personal injury and to protect the device from damage, read and follow these safety precautions.

## General safety precautions

Read all safety and warning guidelines before installing or operating the projector.



**Warning!** If not avoided, the following could result in death or serious injury.

- TRIP OR FIRE HAZARD! Position all cables where they cannot contact hot surfaces, be pulled, be tripped over, or damaged by persons walking on or objects rolling over the cables.
- This product must be installed within a restricted access location not accessible by the general public.
- Only personnel who are trained on the precautions for the restricted access location can be granted entry to the area.
- Install the product so users and the audience cannot enter the restricted area at eye level.
- ELECTRICAL and BURN HAZARD! Use caution when accessing internal components.
- High leakage current present when connected to IT power systems.
- PERMANENT/TEMPORARY BLINDNESS HAZARD! No direct exposure to the beam must be permitted. RG3 IEC 62471-5:2015
- PERMANENT/TEMPORARY BLINDNESS HAZARD! Operators must control access to the beam within the hazard distance or install the product at the height (greater than or equal to 2.0 m or 2.5 m (US only) from the floor to the beam) that prevents exposure of spectators' eyes within the hazard distance.
- Possibly hazardous optical radiation emitted from this product. (Risk group 3 under IEC 62471-5:2015)
- For protection from ultraviolet radiation, keep all product housings intact during operation.
- FIRE AND SHOCK HAZARD! Use only the attachments, accessories, tools, and replacement parts specified by Christie.
- A minimum of four people or appropriately rated lift equipment is required to safely lift, install, or move the product.
- Always install safety straps when the frame and projector are installed overhead.
- Only Christie qualified technicians who are knowledgeable about the hazards associated with laser use, high-voltage, and high temperatures generated by the product are authorized to assemble, install, and service the Christie Laser Projection System.

## AC/power precautions

Read all safety and warning guidelines before connecting to AC power.



**Warning!** If not avoided, the following could result in death or serious injury.

- SHOCK HAZARD! Only use the AC power cord provided with the product or recommended by Christie.
- FIRE AND SHOCK HAZARD! Do not attempt operation unless the power cord, power socket, and power plug meet the appropriate local rating standards.
- SHOCK HAZARD! Do not attempt operation if the AC supply is not within the specified voltage and power range, as specified on the license label.
- SHOCK HAZARD! The AC power cord must be inserted into an outlet with grounding.
- SHOCK HAZARD! A dedicated, protected ground or earth wire must be installed on the product by Christie qualified technicians or electricians before it can be connected to power.
- SHOCK HAZARD! Disconnect the product from AC before moving, servicing, cleaning, removing components, or opening any enclosure. Inputs A and B must be removed prior to servicing.
- Install the product near an easily accessible AC receptacle.
- The appliance coupler and main power supply plug must be easily accessible for disconnecting the product from the power source.



**Caution!** If not avoided, the following could result in minor or moderate injury.

- FIRE HAZARD! Do not use a power cord, harness, or cable that appears damaged.
- FIRE OR SHOCK HAZARD! Do not overload power outlets and extension cords.
- SHOCK HAZARD! Power supply uses double pole/neutral fusing. Disconnect all power sources before opening the product.
- Only Christie qualified technicians are permitted to open product enclosures.

## Light intensity hazard distance

This projector has been classified as Risk Group 3 as per the IEC62471-5 standard due to possible hazardous optical and thermal radiation being emitted.



**Warning!** If not avoided, the following could result in serious injury.

- PERMANENT/TEMPORARY BLINDNESS HAZARD! No direct exposure to the beam must be permitted. RG3 IEC 62471-5:2015
- PERMANENT/TEMPORARY BLINDNESS HAZARD! Operators must control access to the beam within the hazard distance or install the product at the height (greater than or equal to 2.0 m or 2.5 m (US only) from the floor to the beam) that prevents exposure of spectators' eyes within the hazard distance.
- EXTREME BRIGHTNESS! Do not place reflective objects in the product light path.

The following diagram and table show the zones for optical and thermal radiation hazard distances:

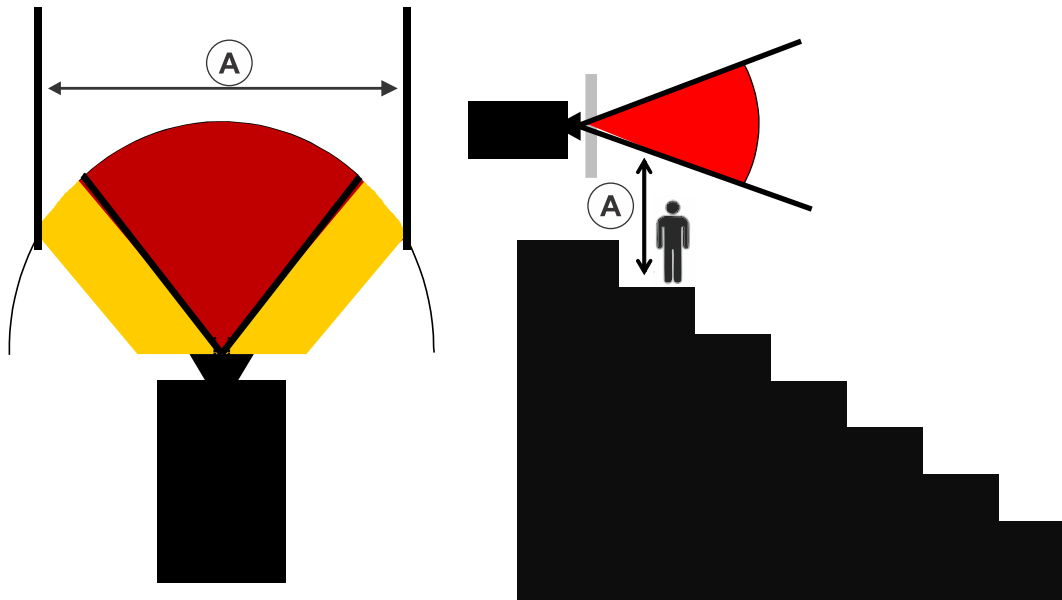

- Zone A—The light intensity may cause eye damage after a momentary or brief exposure (before a person can avert his or her eye away from the light source). The light may cause skin burns to occur.

Within Zone A, ensure the beam is at least 2.0 m, or 2.5 m (US only), above the floor where the audience is permitted to stand, with at least 1.0 m clearance below or lateral.

For US market only, hazard distances based upon FDA guidance document 1400056, *Classification and Requirements for Laser Illuminated Projectors (LIPs)*, dated February 18, 2015:

Projection lens	Part number	Zone A (m)
1.2-1.72:1, 0.69" DLPCine zoom lens	108-494108-XX	0 to 1.6
1.33-2.1:1, 0.69" DLPCine zoom lens	108-495109-XX	0 to 2.2
1.62-2.7:1, 0.69" DLPCine zoom lens	108-496100-XX	0 to 3.0
2.09-3.9:1, 0.69" DLPCine zoom lens	108-497101-XX	0 to 4.4

For all other markets, hazard distances based upon IEC 62471-5:2015, *Photobiological safety of lamps and lamp systems – Part 5: Image projectors*:

Projection lens	Part number	Zone A (m)
1.2-1.72:1, 0.69" DLPCine zoom lens	108-494108-XX	0 to 0.8
1.33-2.1:1, 0.69" DLPCine zoom lens	108-495109-XX	0 to 1.0
1.62-2.7:1, 0.69" DLPCine zoom lens	108-496100-XX	0 to 1.3

<b>Projection lens</b>	<b>Part number</b>	<b>Zone A (m)</b>
2.09-3.9:1, 0.69" DLPCine zoom lens	108-497101-XX	0 to 1.9

# Introduction

This manual is intended for operators of Christie CP2208-LP projection systems.

This manual provides operational instructions. For projector setup instructions, refer to the *CP2208-LP Setup and Installation Manual (P/N: 020-102152-XX)*.

## Projector components (front)

Learn about the components on the front of the projector.

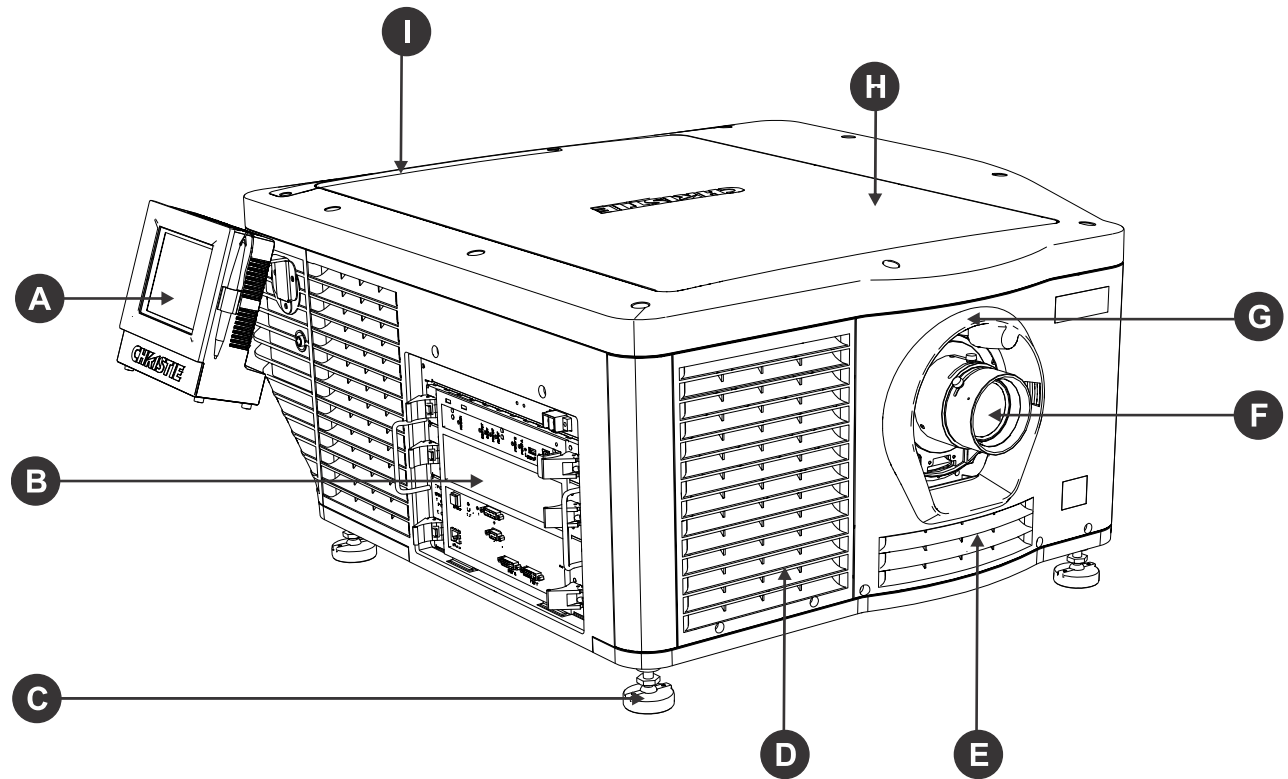

A	Touch panel controller (TPC) A touch-sensitive screen used to control the projector.
B	Communications panel External devices are connected here.
C	Adjustable feet

	Turn the adjustable feet to increase or decrease the projector height.
D	Air filter
E	Air intake with air filter behind it.
F	Projector lens A list of available lenses is available in the <i>projector specifications</i> (on page 62).
G	Lens surround
H	Top skin
I	Air filter

## Projector components (rear)

Learn about the components on the back of the projector.

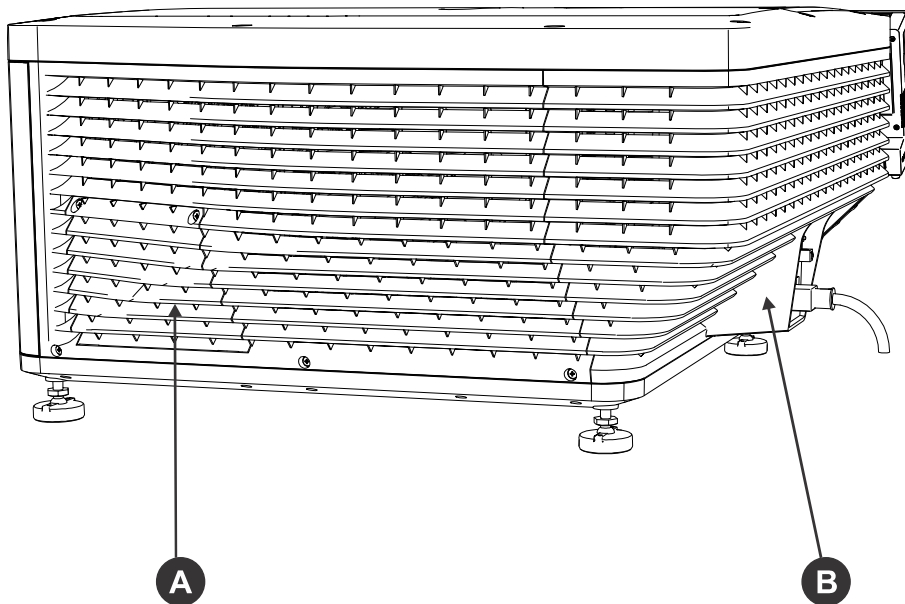

A	Service access door
B	Power cord and AC receptacle

# Accessing the projector and running diagnostics

Learn how to access the projector and run projector diagnostic utilities.

## The touch panel controller

The touch panel controller (TPC) is a touch-sensitive screen that you use to control the projector. You can use the TPC to turn the projector and light source on or off, select channels, and view status information. The TPC is mounted on the side of the projector. Use the USB port on the side of the TPC to download log files and install software upgrades.













If the TPC fails or is disconnected, tap the emergency start button on the communications panel. This starts the projector, turns the light source on, and opens the douser. When using the emergency start button, you cannot change channels.



Use the main screen of the TPC to access power, light source, douser, channel, and test pattern settings.



Control	Image	Description
<b>System status</b>		



Control	Image	Description
Status LED		Displays a green, yellow, or red LED. A green LED indicates that the projector is operating properly. If a monitored system falls below a normal reading, the LED is yellow or red. A yellow LED indicates a warning, and a red LED indicates a critical error that you must correct. Tap the status LED to open the Status window and resolve issues.
<b>Preferred channels</b>		
Channel buttons		Displays custom projector settings.
All channels button		Displays 64 saved channels.
<b>Power</b>		
Power off		Turns the projector on or off. Tap off to place the projector in stand-by mode. To prevent accidental activation, tap and hold the on or off buttons. A message displays in the title bar when the projector turns on or off.
Power on		
<b>Light</b>		
Light off		Turns the light source on or off. To prevent accidental activation, tap and hold the on or off buttons. A boot delay occurs if you turn the light source on before turning on the projector power.
Light on		
<b>Douser</b>		
Douser closed		Opens or closes the douser.
Douser opened		
<b>Lens adjust</b>		
Lens adjust		Controls the Intelligent Lens System (ILS) lens motors. Tap to open the ILS File Setup window.
<b>Test pattern</b>		
Disable pattern		Selects or disables test patterns.
Select test pattern		
<b>Operational status</b>		
Status LED		Displays the status of projector functions including the Projector Intelligence Board (PIB), the Integrated Cinema Processor Board (ICP), Integrated Media Block (IMB), standby power, main power, run, and marriage. A green LED indicates the system is functioning correctly. A red LED indicates a critical error that you must correct. Tap the status LED to open the Status window and resolve issues.
<b>Bottom bar</b>		

Control	Image	Description
Menu		Tap the Menu button to access projector menus.
Status icons		These icons change as these elements update from changes on the projector. The current time also displays.
Select test pattern		Tap the Select Test Pattern icon to open the Preferred Test Patterns window and select a test pattern to display.

## Turning the projector on

The projector is turned on using the touch panel controller (TPC).



**Warning!** If not avoided, the following could result in death or serious injury.

- SHOCK HAZARD! Do not attempt operation if the AC supply is not within the specified voltage and power range, as specified on the license label.

1. Ensure that the circuit breaker for the projector is on.
2. On the TPC, tap and hold **Power On**. 

## Logging on to the projector

Log on to the projector to access the touch panel controller (TPC) functions.

1. On the TPC, tap **Menu > Login**.
2. From the Username list, select a user name.  
Each user account has set user access permissions.
3. In the Password field, type the password.
4. Tap **Login**.

### Related information

*Interpreting user access permissions* (on page 43)

## Viewing the status of projector components

The Status window displays information about the status of projector components.

The left pane lists projector components and their status. The right pane displays detailed information about individual projector items.

A green LED indicates the item is functioning correctly. A yellow LED is a warning that a projector item requires attention. A red LED indicates a projector item requires immediate attention.



If the Interlocks status LED is yellow or red, contact Christie technical support.

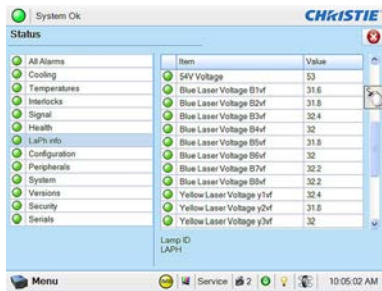

1. On the touch panel controller (TPC), tap **Menu > Status**.
2. Tap an item in the left pane to view its detailed information.

If the Item or Value descriptions are too long for the cell, tap the description to view the full description at the bottom of the window. To adjust the width of a column in the left pane, tap and drag the column border. When you close the Status window, the column widths return to their default size.

## Running the projector interrogator

The interrogator captures diagnostic information that you can use to assist Christie service technicians diagnose and correct projector issues.

Image disruption can occur if you run the interrogator during a show. When you run the interrogator, you cannot modify projector settings.

Log files are compressed into a 7z or 7-zip file format. A tool for opening these archives can be downloaded from <http://www.7-zip.org>.

1. On the touch panel controller (TPC), *log on to the projector* (on page 18) with operator, administrator, or service permissions.
2. Tap **Menu > Diagnostics > Interrogator**.
3. Tap one of the following options:
  - **Basic Mode**—A basic projector interrogation that returns only projector log files.
  - **Enhanced Mode**—An enhanced interrogation that returns projector log files and registered batch files.
4. Tap **Yes**.
5. Insert a USB flash drive into the TPC USB port.
6. Tap **Download to USB**.

## Retrieving system logs

System logs can help you identify and correct projector issues.

1. On the touch panel controller (TPC), *log on to the projector* (on page 18) with operator, administrator, or service permissions.
2. Tap **Menu > Diagnostics > System Logs**.
3. From the From list, select a start date for the logs.
4. From the To list, select an end date for the logs.

5. From the Type list, select a log type.
6. From the Severity list, select the severity type.
7. Tap **Retrieve Logs**.
8. Insert a USB flash drive into the TPC USB port.
9. Tap **Download to USB**.

## Running a server test

You can run a server test to search the subtitle and metadata XML files for errors in content or in transmission from the server.

You cannot use a server test to turn metadata or subtitling off or on.

1. On the touch panel controller (TPC), tap **Menu > Diagnostics > Server Test**.
2. If you are searching a metadata file, in the Meta File URI field, enter the location of the file.
3. If you are searching a subtitle file, in the Subtitling URI field, enter the location of the file.

## Responding to alarms

When an alarm occurs, an Alarms window with a red border appears with a description of the alarm condition, state, and time and date of the alarm.

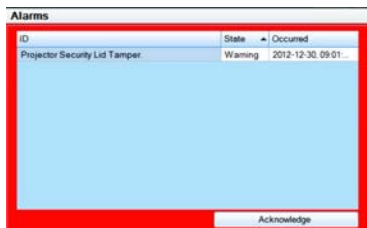

The window only displays alarms you have not previously acknowledged.



1. To acknowledge an alarm and remove it from the Alarms window, tap **Acknowledge**.
2. To view all alarms, in the left pane tap **Menu > Status > All Alarms**.

## Turning the projector off

Complete the following procedure to turn off the projector.

1. On the touch panel controller (TPC), to turn off the light source, tap and hold **Light Off**. 
2. Tap and hold **Power Off**. 

The projector enters a cool down mode and the fans and electronics stay on for 5 minutes. After this cool down period, the projector enters standby mode.
3. If you are servicing the projector or removing the protective cover, disconnect the AC power and turn the breaker off.

# Managing the Digital Light Processing

Learn how to manage the integrated cinema processor (ICP) electronics.

To access the Digital Light Processing (DLP) menus, you need administrator or service permissions.

## Resetting the Digital Light Processing

To remove image artifacts from the screen, try resetting the Digital Light Processing (DLP) before restarting the projector.

Do not reset the DLP if content is playing.

1. On the touch panel controller (TPC), *log on to the projector* (on page 18) with administrator or service permissions.
2. Tap **Menu > Diagnostics > DLP Management**.
3. Tap **Reset DLP**.
4. Tap **Yes**.
5. If an alarm appears, tap **Acknowledge**.

## Running a Digital Light Processing self test

Run a Digital Light Processing (DLP) self test to test the functionality of the Integrated Cinema Processor (ICP) and DLP.

1. On the touch panel controller (TPC), *log on to the projector* (on page 18) with administrator or service permissions.
2. Tap **Menu > Diagnostics > DLP Management**.
3. Tap **DLP Self Test**.
4. Tap **Yes**.
5. To close the results pane, tap **Clear Results**.

## Downloading an integrated cinema processor certificate

The integrated cinema processor (ICP) certificate is used in the creation of key delivery messages (KDM) for the integrated media block (IMB). The ICP certificate represents the projector identity, and is included in the trusted device list portion of the KDM.

1. On the touch panel controller (TPC), *log on to the projector* (on page 18) with administrator or service permissions.
2. Insert a USB flash drive into the touch panel controller (TPC) USB port.
3. Tap **Menu > Diagnostics > DLP Management**.
4. Tap **Download ICP Certificate**.
5. Tap **Close**.

## Disabling the integrated cinema processor signature test

Error messages that appear when the integrated cinema processor (ICP) is turned on and the ICP signature test is run, can disrupt projector network monitoring. Use this procedure to disable the signature test.

1. On the touch panel controller (TPC), *log on to the projector* (on page 18) with administrator or service permissions.
2. Tap **Menu > Diagnostics > DLP Management**.
3. Tap **DLP Self Test**.
4. Tap **Yes**.

To re-enable the ICP signature test, clear the **Bypass Signature Test** check box.

# Managing the light source information

Learn how to manage the settings for the light source.

## Creating a new light source file

Create a light source file to store power settings for the light source.

A colorimeter is required to complete this procedure.



Do not take any on screen measurements while on the Light Power/LiteLOC Setup screen. The on-screen color is corrected and does not show the native output.

1. On the touch panel controller (TPC), tap **Menu > Advanced Setup > MCGD File Setup**.
2. To display the white test pattern, in the white area of the chromaticity image, tap the option button.
3. Using the colorimeter, measure the on-screen luminance at the center of the screen.
4. Write down the X and Y values.
5. Tap **Menu > Advanced Setup > Light Power/LiteLOC Setup**.

The following adjustable fields are available:

Field	Description
Power %	Sets the percentage of power to supply to the light source.
Advanced Power Adjust	Enables or disables advanced power adjust mode. When enabled, you can adjust the percentage of power to supply to the yellow laser and blue laser individually.
Enable LiteLOC™	Enables or disables LiteLOC™. LiteLOC™ is a power control algorithm that increases the power level to maintain brightness.
Light Meter - Set Target	Enables LiteLOC™ and maintains the current brightness level for as long as possible. The light meter value is an arbitrary unit of measure, not lumens or fL.

6. Adjust the value in the Power % field and repeat steps 1 to 4, until the measured luminance is close, but slightly higher than, the required luminance from the DCI specifications.  
Tap **Save** and return to the MCGD File Setup screen each time an on-screen measurement is taken, to ensure uncorrected colors are being read.

Always set measured luminance value higher than the specified value prior to color correction, as color correction decreases light output.

7. Tap **Advanced Power Adjust**.
8. Individually adjust the Yellow and Blue power settings, returning to the MCGD File Setup screen after each adjustment to measure the uncorrected color on-screen.
9. On the Light Power/LiteLOC Setup screen, tap **Save As**.
10. In the Filename field, type a name for the light source file.
11. Tap **OK**.

## Modifying an existing light source file

You can change the settings for an existing light source file.

1. On the touch panel controller (TPC), tap **Menu > Advanced Setup > Light Power/LiteLOC Setup**.
2. From the Current Light File list, select a light source file.
3. Modify the file settings as required.
4. Tap **Save**.  
If you want to revert your changes, tap **Revert** before you tap **Save**.

## Enabling or disabling LiteLOC on a light source file

LiteLOC™ is a power control algorithm that increases the power level to maintain brightness.

1. On the touch panel controller (TPC), tap **Menu > Advanced Setup > Light Power / LiteLOC Setup**.
2. In the Current Light File list, select a light file.
3. Tap **Enable LiteLOC** to enable LiteLOC or clear the **Enable LiteLOC** check box to disable LiteLOC.
4. Tap **Save**.

## Adjusting light source power

You can increase or decrease the percentage of power to supply to the light source.

If LiteLOC™ is enabled, entering a new power percentage temporarily disables LiteLOC™ settings.

1. Tap **Menu > Advanced Setup > Light Power/LiteLOC Setup**.
2. Increase or decrease the **Power %** value.
3. Tap **Set Target**.
4. Select **Enable LiteLOC**.



## Verifying the light source sensor readings

Check the light sensor readings that appear on the Light Power/LiteLOC Setup screen.

1. On the touch panel controller (TPC), tap **Menu > Advanced Setup > Light Power/LiteLOC Setup**.
2. Check the following fields:

Field	Description
~fL or ~cd/m <sup>2</sup>	Displays the approximate Foot Lamberts reading on the light sensor. This assumes a calibration was performed.
Hours	Displays the number of hours the light source has operated.
Target %	Displays the percentage of power of the yellow and blue laser that is read on the light sensor.
Current	Displays the current of the yellow and blue laser that is read on the light sensor.
Intensity	Displays the current light sensor reading in arbitrary units of measure; it does not represent actual lumens or fL.

# Working with channels

Create channels to store customized projector settings for different inputs.

## Creating a new channel

You can create a maximum of 64 channels.

1. On the touch panel controller (TPC), *log on to the projector* (on page 18) with advanced, administrator, or service permissions.
2. Tap **Menu > Channel Setup**.
3. From the Channel Name list, select a channel.
4. Tap the **Launch Dialog** icon:



5. Enter a name for the channel and tap **Enter**.
6. On the Config 1 screen, complete the following fields:

Field	Description
Icon	The icon associated with the channel.
Input	The location or connection for the current input.
Data Format	The source color depth (8-10-12 bit) for the channel.
Source File	The resolution and aspect ratio for the channel.
Screen File	The screen type, masking, cropping, and lens settings for the channel.
Use PCF	Associates the channel with a projector configuration file (PCF) and prevents channel adjustments.
PCF	The PCF file associated with the channel.
Light File	The light file associated with the channel. To edit the light file settings, tap the <b>Launch Dialog</b> icon:  Any changes made to the light file settings are applied to all channels that use this light file.
ILS File	The intelligent lens system (ILS) file associated with the channel. The ILS file automatically adjusts the lens position so

Field	Description
	<p>the content displays correctly. To edit ILS file settings, tap the <b>Launch Dialog</b> icon:</p>  <p>Any changes made to the ILS file settings are applied to all channels that use this ILS file.</p>



7. In the left pane, tap **Config 2**.
8. Complete the following fields:

Field	Description
Measured Color	The measured color gamut data (MCGD) file used to calculate target color processing.
Target Color	The target color gamut data (TCGD) value. This option is not available when Use PCF is selected in the Config 1 screen.
Color Space	The method of color decoding for the current source. The default is YCbCr for all DVI sources. The default for all cinema sources is Unity RGB. This option is not available when Use PCF is selected in the Config 1 screen.
Gamma	The gamma correction required for the proper tonal range of the source material. This option is not available when Use PCF is selected in the Config 1 screen.
LUT_CLUT	Look up table (LUT) or color look up table (CLUT). Applies a 3D color cube for increased color accuracy. This option is not available when Use PCF is selected in the Config 1 screen.
Scan Type	The video scan type. The default is <b>Progressive</b> .
Automatic Scan Type Detection	Automatically performs scan type detection. This feature is supported for PIBS1 inputs only.
Use PCT	Applies Christie Pureformity Color Technology (PCT) to the channel.
PCT File	Identifies the Christie Pureformity Color Technology (PCT) file associated with the channel.
HDMI EDID Type	Identifies the extended display identification data (EDID) type used by the channel when playing content from a device connected to the HDMI A/LEFT or HDMI B/RIGHT ports.
Enable 3D Dual Measured Color	Enables 3D Dual Measured Color on the channel. Select the color files for the left and right eyes.

9. If the channel is being created to display 3D content, tap **3D Control** in the left pane.
10. Complete the following fields:

Field	Description
Enable 3D	Enables 3D.
3D Test Patterns	Displays 3D test patterns.

Field	Description
3D Sync Input Mode	<p>Specifies whether a specific frame of input data has left eye or right eye data.</p> <p>Select <b>Use White Line Code (true and inverted)</b> if you are using a single 3D input signal in which an embedded white line at the bottom of each frame identifies left and right, and an additional separate 3D stereo sync input at the GPIO port is not present. The bottom row of the left-eye sub-field should be pure white for the left-most 25% of the pixel row and pure black for the remainder of the row. The bottom row of the right-eye sub-field should be pure white for the left-most 75% of the pixel row and pure black for the remainder of the row.</p> <p>Select <b>Use Line Interleave for 3D source data only</b>. When specified, the ICP will de-interleave each line into the left image or right image in memory as specified. Line interleave can be used with PsF 3D data (left and right data for one field, then left and right data for second field).</p>
L/R Display Reference	<p>Specifies which frame of eye data to display during a specific display frame. This signal is referenced to the display frame rate which is specified by the Frame Rate N:M.</p>
Frame Rate N:M	<p>Sets how many frames to display per number of frames that form one complete image. Increase the display frame rate to reduce flicker from your source(s).</p>
L/R Display Sequence	<p>Defines the frame order (L-R or R-L) required for 3D perspective. This option only has meaning when the Frame Rate factor M is equal to 2. For this case, two input frames of data are required to constitute a complete frame of image data. This parameter tells the system which frames go together to make a complete image. When using Line Interleave as the 3D Sync Input Mode, ensure that Left (L1R1 L2R2) is selected.</p>
3D Sync Polarity	<p>Keeps 3D stereo sync output the same as input (true) or reversed (inverted).</p> <p>True: 3D L/R sync output from GPO will match L/R sync input.            Inverted: 3D L/R sync output from GPO will be the opposite of sync input (left = right, right = left).</p>
Dark Time	<p>Creates a blank time interval between left and right frames to allow for LCD shutter glasses, Z screen, or rotating 3D wheel to synchronize the output. See Output Delay information below. Values between 0 and 65535 are accepted. To enter the dark time value, tap the <b>Launch Dialog</b> icon:</p> 
Output Delay	<p>The non-image time in Microseconds (<math>\mu</math>). Offset 3D stereo sync output in relation to dark time interval. Acceptable values are between -32768 and 32767 are accepted where a positive offset = delay and negative offset = start early. To enter the output delay value, tap the <b>Launch Dialog</b> icon:</p>

Field	Description
	
Phase Delay	The degree of reference between the left and right sync output. Values between -180 and 180 are accepted. To enter the phase delay value, tap the <b>Launch Dialog</b> icon: 

11. To activate the channel, tap **Activate**.

## Activating a channel

To use the customized projector settings saved in a channel, activate the required channel.

1. On the touch panel controller (TPC), *log on to the projector* (on page 18) with advanced, administrator, or service permissions.
2. Tap **Menu > Channel Setup**.
3. From the Channel Name list, select a channel.
4. To activate the channel, tap **Activate**.

## Restoring default channel settings

Complete the following procedure to restore default channel settings.

1. On the touch panel controller (TPC), *log on to the projector* (on page 18) with advanced, administrator, or service permissions.
2. Tap **Menu > Channel Setup**.
3. From the Channel Name list, select a channel.
4. Tap **Defaults**.
5. Do one of the following:
  - To restore the default settings to the selected channel, tap **Default Current Channel**.
  - To restore the default settings to all channels, tap **Default All Channels**.
6. Tap **OK**.

## Changing the channel icon

Complete the following procedure to change the channel icon.

1. On the touch panel controller (TPC), *log on to the projector* (on page 18) with advanced, administrator, or service permissions.
2. Tap **Menu > Channel Setup**.
3. From the Channel Name list, select a channel.
4. Tap **Icon**.

5. Tap an icon.
6. Tap **OK**.

## Adding or removing preferred channels

Complete the following procedure to add or remove channels from the Preferred Channels pane.

1. On the touch panel controller (TPC), *log on to the projector* (on page 18) with administrator or service permissions.
2. Tap **Menu > Administrator Setup > Preferred Channel Setup**.
3. To add a channel to the Preferred Channels pane, tap and drag a channel from the **All Channels** list to the **Selected Channel Buttons (Drag and Drop)** pane.
4. To remove a channel from the Preferred Channels pane, tap and drag a channel from the **Selected Channel Buttons (Drag and Drop)** pane to the recycle bin in the bottom right corner.

# Managing projector setting files

Learn how to create and modify the projector settings files.

## Creating a source file

Create source files to store resolution, offset, and aspect ratio settings for input devices.

1. On the touch panel controller (TPC), tap **Menu > Advanced Setup > Source File Setup**.
2. Tap **Save As**.
3. In the **Filename** field type a name for the source file.
4. Tap **OK**.
5. Enter values in these areas:
  - **Resolution**—The X and Y resolution of the incoming signal. For example, 2048 (X) and 858 (Y) or 1920 (X) and 1080 (Y). The resolution must match the incoming signal format.
  - **Offset**—The amount of incoming data to discard. Set the values to zero to process all incoming data. The allowable X range is -4096 to 4096 pixels and Y range of -2160 to 2160 pixels.
  - **Aspect ratio**—The aspect ratio for the incoming signal. The allowable range is 0 to 7.99.
6. Tap **Save**.

## Modifying a source file

You can change the settings in a source file after it is created.

1. On the touch panel controller (TPC), tap **Menu > Advanced Setup > Source File Setup**.
2. From the Current Source File list, select the source file to edit.
3. Modify the **Resolution**, **Offset**, or **Aspect Ratio** values.
4. Tap **Save**.

## Creating a screen file

Use screen files to define the size of the display panel and image cropping.

The same screen file can be assigned to multiple input devices.

1. On the touch panel controller (TPC), tap **Menu > Advanced Setup > Screen File Setup**.
2. Tap **Save As**.
3. In the **Filename** field type a name for the screen file.
4. Tap **OK**.
5. Enter values in these areas:
  - **Letter Box**—All image data is displayed and the aspect ratio is maintained.
  - **Lens Factor**—The amount to stretch an image horizontally. Allowable values can range from 0.00 to 7.99. Type 1 if you are not using an anamorphic lens.
  - **Presentation**—The size and location of the image. By default, the projector uses a 2048 x 1080 panel.
  - **Cropping**—Hides unwanted image data.
6. Tap **Save**.

## Modifying a screen file

You can change the settings in a screen file after it is created.

1. On the touch panel controller (TPC), tap **Menu > Advanced Setup > Screen File Setup**.
2. From the Current Screen File list, select the screen file to edit.
3. Modify the screen file settings.
4. Tap **Save**.

## Creating a measured color gamut data file

Create measured color gamut data (MCGD) files to correct on-screen colors.

A colorimeter is required to complete this procedure.

1. Turn on the light source and allow it to operate for 20 minutes.
2. On the touch panel controller (TPC), tap **Menu > Advanced Setup > MCGD File Setup**.
3. Tap **Save As**.
4. In the **Filename** field type a name for the MCGD file.
5. Tap **OK**.
6. To display the red test pattern, in the red area of the chromaticity image tap the option button.
7. Measure the red chromaticity with the colorimeter.
8. Record the red chromaticity value.
9. Repeat steps 6 to 8 for the green, blue, white, and black chromaticity measurements.  
Select the test pattern that matches the color you are measuring.



10. Enter the chromaticity measurements you recorded in step 7 in the red, green, blue, white, and black **x** and **y** fields.
11. If the MCGD file will be associated with a 3D channel, tap **Enable 3D** and select a frame rate.
12. Tap **Save**.

## Modifying a measured color gamut data file

You can change the settings in a measured color gamut data (MCGD) file after it is created.

1. On the touch panel controller (TPC), tap **Menu > Advanced Setup > MCGD File Setup**.
2. From the Current Measured (MCGD) File list, select the MCGD file to edit.
3. Modify the MCGD file settings.
4. Tap **Save**.

## Creating a target color gamut data file

Create a target color gamut data (TCGD) file with the settings defined by your content provider.

A colorimeter is required to complete this procedure.

1. Turn on the light source and allow it to operate for 20 minutes.
2. On the touch panel controller (TPC), tap **Menu > Advanced Setup > TCGD File Setup**.
3. Tap **Save As**.
4. In the **Filename** field type a name for the TCGD file.
5. Tap **OK**.
6. Tap **Display Test Pattern**.
7. To display the red test pattern, in the red area of the chromaticity image tap the option button.
8. Measure the red chromaticity with the colorimeter.
9. Enter the red chromaticity values in the **x**, **y**, and **Gain** fields.
10. Select the test pattern that matches the color you are measuring and repeat steps 6 to 8 for the magenta, blue, white, yellow, and green chromaticity measurements.
11. Tap **Save**.

## Modifying a target color gamut data file

You can change the settings in a target color gamut data (TCGD) file after it is created.

1. On the touch panel controller (TPC), tap **Menu > Advanced Setup > TCGD File Setup**.
2. From the Current Target (TCGD) File list, select the TCGD file to edit.
3. Modify the TCGD file settings.
4. Tap **Save**.

## Creating a new intelligent lens system file

Create a new file for the intelligent lens system (ILS).

You must *calibrate the lens* (on page 36) before creating a new ILS file.

1. On the touch panel controller (TPC), tap **Menu > Advanced Setup > ILS File Setup**.
2. Tap **Save As**.
3. In the **Filename** field, enter a name for the ILS file.
4. Tap **OK**.
5. To adjust the focus of the image on the screen, in the Focus area, tap the left or right icons.
6. To adjust the image size, in the Zoom area, tap the positive or negative icons.
7. To move the position of the image on the screen, in the Offset area, tap the forward, backward, left, or right arrow icons.
8. Tap **Save**.

## Editing an existing intelligent lens system file

You can change an existing intelligent lens system (ILS) file if required.

1. On the touch panel controller (TPC), tap **Menu > Advanced Setup > ILS File Setup**.
2. From the Current ILS File list, select an ILS file.
3. To adjust the focus of the image on the screen, in the Focus area, tap the left or right icons.
4. To adjust the image focus, in the Zoom area, tap the positive or negative icons.
5. To move the position of the image on the screen, in the Offset area, tap the forward, backward, left, or right arrow icons.
6. Tap **Save**.

## Enabling automatic intelligent lens system adjustments on a channel

Enable or disable automatically adjusting the intelligent lens system (ILS) on a channel.

1. On the main screen of the touch panel controller (TPC), in the Preferred Channels pane, tap a channel.
2. Tap **Lens Adjust**.
3. Select **Enable Automatic ILS**.
4. Tap **OK**.

## Resetting intelligent lens system file settings

Reset the intelligent lens system (ILS) file settings to the default settings.

You must reset the ILS when you move the lens, you have manually adjusted horizontal or vertical offset, focus, or zoom or when a power outage occurs during a channel change.

1. On the touch panel controller (TPC), tap **Menu > Advanced Setup > ILS File Setup**.
2. From the Current ILS File list, select an ILS file.
3. Tap **Quick Reset**.
4. Tap **Yes**.

## Adding a lens serial number

Add the serial number for the lens to help identify it.

1. On the touch panel controller (TPC), tap **Menu > Advanced Setup > Lens Setup**.
2. From the Primary Lens list, select a lens.
3. In the Serial Number field, tap the **Launch Dialog** (□) icon.
4. Enter the serial number for the lens.
5. Tap **Enter**.
6. Tap **Save**.

## Enabling an automatic intelligent lens system on a lens

Use this procedure to move the lens to a position specified by the channel settings.

1. On the touch panel controller (TPC), tap **Menu > Advanced Setup > Lens Setup**.
2. From the Primary Lens list, select a lens.
3. In the Intelligent Lens System area, tap **Enable Automatic ILS**.

## Resetting the lens position on projector startup

You can reset the lens position to a default location each time the projector starts up.

We recommend performing this task daily to reduce the risk of large variations in image position and quality.

1. On the touch panel controller (TPC), tap **Menu > Advanced Setup > Lens Setup**.
2. From the Primary Lens list, select a lens.
3. In the Intelligent Lens System area, tap **Reset on Startup**.

## Completing a full lens calibration

Ensure the lens is calibrated before using the projector.

Complete this task whenever a projection lens is installed.

1. On the touch panel controller (TPC), tap **Menu > Advanced Setup > Lens Setup**.
2. From the Primary Lens list, select a lens.
3. In the Intelligent Lens System area, tap **Full Calibration**.
4. Tap **Yes**.

## Resetting the intelligent lens system and the lens position

Reset the intelligent lens system (ILS) and the lens to the default position.

1. On the touch panel controller (TPC), tap **Menu > Advanced Setup > Lens Setup**.
2. From the Primary Lens list, select a lens.
3. In the Intelligent Lens System area, tap **Quick Reset**.
4. Tap **Yes**.

# Scheduling events

Use the scheduler to determine when the projector turns on or off.

## Scheduling the projector to turn on or off

Set up an automatic schedule for when the projector turns on or off.

1. On the touch panel controller (TPC), *log on to the projector* (on page 18) with administrator or service permissions.
2. Tap **Menu** > **Administrator Setup** > **Scheduler**.
3. Tap **Enable Scheduler**.
4. To view the available dates, tap and drag the scroll bar.
5. Tap a square below the date and next to the time that you want the projector to turn on or off.
6. Tap **New**.
7. Determine when the projector turns on or off.
  - To turn the projector off at a specific date and time, tap **Power Off**.
  - To turn the projector on at a specific date and time, tap **Power On**.
8. To enable or disable the scheduled event, tap **Start**.  
New scheduled events are enabled by default.
9. Select a date and a time for the scheduled event.
10. To determine when the event occurs, do one of the following:
  - To have the scheduled event occur weekly, tap **Weekly** and then select the days that you want the event to occur.
  - To have the scheduled event occur once at a specific date and time, tap **Once**.
11. Tap **Expire**.
12. Select the date you want a weekly event to expire.
13. Tap **Save**.
14. To return to the calendar view, tap **OK**.

## Editing a scheduled event

You can change a an event after it has been scheduled.

1. On the touch panel controller (TPC), *log on to the projector* (on page 18) with administrator or service permissions.
2. Tap **Menu > Administrator Setup > Scheduler**.
3. To view the available dates, tap and drag the scroll bar.
4. Tap the event you want to edit.
5. Tap **Edit**.
6. Adjust the settings for the event.
7. Tap **Save**.
8. To return to the calendar view, tap **OK**.

## Deleting a scheduled event

Delete a scheduled event if it is no longer required.

1. On the touch panel controller (TPC), *log on to the projector* (on page 18) with administrator or service permissions.
2. Tap **Menu > Administrator Setup > Scheduler**.
3. To view the available dates, tap and drag the scroll bar.
4. Tap the event you want to delete.
5. Tap **Delete**.
6. To return to the calendar view, tap **OK**.

## Deleting all scheduled events

If all of the scheduled events are no longer required, you can delete them.

1. On the touch panel controller (TPC), *log on to the projector* (on page 18) with administrator or service permissions.
2. Tap **Menu > Administrator Setup > Scheduler**.
3. Tap **Delete All**.
4. Tap **Yes**.

## Turning off the scheduler

Turn off scheduler if you do not plan to use this feature.

1. On the touch panel controller (TPC), *log on to the projector* (on page 18) with administrator or service permissions.
2. On the touch panel controller (TPC), tap **Menu > Administrator Setup > Scheduler**.
3. Tap to clear the **Enable Scheduler** check box.

# Viewing and modifying projector settings

Learn how to modify projector settings including the touch panel controller (TPC) language, TPC screen brightness, and time settings.

## Setting projector and touch panel controller preferences

You can adjust various administrator preferences for the projector and touch panel controller (TPC).

1. On the touch panel controller (TPC), *log on to the projector* (on page 18) with administrator or service permissions.
2. Tap **Menu > Administrator Setup > Preferences**.
3. Adjust the following settings as required:

Field	Description
Temperature Units	Displays temperature information in Celsius or Fahrenheit.
Image Orientation	Sets the direction of the on-screen image.
Luminance Units	Displays luminance information in Foot Lamberts or Candela.
Language	Sets the language for the TPC and online help.
Beep on Screen Press	Plays a sound when you tap the TPC screen.
Enable Screen Saver / Screen Saver Delay	Enables a screen saver and determines the frequency that the screen saver appears.
Over Temperature, Fan Failure, Light Intensity Warning	Opens an alarm window when a pre-defined event occurs.
Brightness	Adjusts the brightness of the TPC display.
Calibrate Screen	Opens the Calibrate window and starts the TPC calibration.
IMB Powered in Standby Mode	Sets whether or not the Integrated Media Block (IMB) is powered when the standby power supply is active.

## Adjusting projector time settings

You can adjust various time settings for the projector.

1. On the touch panel controller (TPC), *log on to the projector* (on page 18) with administrator or service permissions.
2. Tap **Menu > Administrator Setup > Time Setup**.
3. Adjust the following settings as required:

Field	Description
Time Zone	Sets the time zone where the projector is installed.
24 Hour Time	Displays time in a 24-hour format.
Adjust for Daylight Savings Time	Automatically adjusts the time for daylight savings.
Time Offset	Increases or decreases the projector time.
Apply Time Adjustment	Applies time adjustment settings.

## Adding or modifying projector communication settings

To allow a computer or other devices to communicate with the projector, add the projector to a network. You can also modify the communication settings if any network information changes.

1. On the touch panel controller (TPC), *log on to the projector* (on page 18) with administrator or service permissions.
2. Tap **Menu > Administrator Setup > Communications Configuration**.
3. Complete these fields:

Field	Description
Device Name	The name of the projector.
IP Address	The IP address of the projector.
Subnet Mask	The subnet mask to which the address belongs.
Gateway	The IP address for the network gateway.
Apply	Applies Ethernet settings.
Serial Speed (Baud)	The baud rate of the serial port. The default is 115200.
Enable SNMP	Enables SNMP.
SNMP V2 / SNMP V3	The SNMP protocol type. Contact Christie for the SNMP V3 user ID and password.
Management IP	The IP address where SNMP information and notifications are sent.
Download MIB to USB	Sends the SNMP Management Information Base (MIB) file to a USB flash drive.
Apply	Applies SNMP settings.



Field	Description
Serial Access	Grants access to serial connections.
Ethernet Access	Grants access to Ethernet connections.

## Adding a network device

Learn how to add a network device.

1. On the touch panel controller (TPC), *log on to the projector* (on page 18) with administrator or service permissions.
2. Tap **Menu** > **Administrator Setup** > **Network Devices Setup**.
3. Tap the check box.  
If the check box is not selected, the device does not appear in the **Network Devices** menu.
4. Tap the **Launch Dialog** (☐) icon in the **Device Name** field and type a name for the network device.
5. Tap **Enter**.
6. Tap the **Launch Dialog** icon in the URL field and type the URL for the network device.
7. Tap **Enter**.

## Accessing a network device

Learn how to interact with network devices.

1. On the touch panel controller (TPC), tap **Menu** > **Network Devices** > **Christie ACT**.
2. To interact with the device tap ☐ in the top-right corner of the window.

## Calibrating the internal light meter

Calibrate the internal light meter to Foot Lamberts with the Foot Lamberts Calibration wizard.

If content is playing when you run the Foot Lamberts Calibration wizard, playback stops.

1. On the touch panel controller (TPC), *log on to the projector* (on page 18) with administrator or service permissions.
2. Tap **Menu** > **Administrator Setup** > **Foot Lamberts Calibration**.
3. Tap **Next** and complete the Foot Lamberts Calibration wizard.

## Viewing processes and programs running on the projector

Use the Microsoft Task Manager to view information about performance measures and programs or processes running on your projector.

1. On the touch panel controller (TPC), tap **Menu** > **Service Setup** > **System Access**.

2. Tap **Task Manager**.
3. Tap **OK**.

## Viewing local or remote computer settings

Use the Microsoft Windows Computer Management console to manage local or remote computer settings.

1. On the touch panel controller (TPC), tap **Menu > Service Setup > System Access**.
2. Tap **Computer Management**.
3. Tap **OK**.

## Viewing the files on the projector

Microsoft Windows Explorer displays the hierarchical structure of files, folders, and drives on your projector.

1. On the touch panel controller (TPC), tap **Menu > Service Setup > System Access**.
2. Tap **Windows Explorer**.
3. Tap **OK**.

## Viewing and modifying network connections

Use the Microsoft Network Connections window to view and modify network connections.

1. On the touch panel controller (TPC), tap **Menu > Service Setup > System Access**.
2. Tap **Network Connections**.
3. Tap **OK**.

## Viewing projector information

The About window provides projector information including the serial number, the current software version, the digital light processing (DLP) version, and the lens type.

- On the touch panel controller (TPC), tap **Menu > About**.

# Managing user accounts

You can add, delete, and modify user accounts.

## Interpreting user access permissions

This table lists the touch panel controller (TPC) permissions.

Permission	Description
Status	Can view basic projector status, diagnostic information and software version information. This is the default level for Serial Communication sessions.
Operator	Can activate channels and test patterns, view detailed diagnostic logs for in-depth troubleshooting and view server errors. This is the default level at the TPC.
Advanced	Can define all display setups such as source resolution, aspect ratio, image cropping, and color gamut information, optimize light output, record light changes, and define setup files as selectable choices for processing a variety of incoming signals.
Administrator	Can perform screen Foot Lambert calibration, define Ethernet settings (IP network address), restore backup files, and upgrade the system software. Administrators can add users and set user access rights from its own level and below only.
Service	Can access all windows on the TPC, except marriage.
Marriage	Can access all windows on the TPC, including marriage.

## Adding a user account

You can create a new user account.

1. On the touch panel controller (TPC), *log on to the projector* (on page 18) with administrator or service permissions.
2. Tap **Menu > Administrator Setup > User Accounts**.
3. Tap **Add**.
4. In the Username field, tap the **Launch Dialog** icon:



5. Enter the user name and tap **Enter**.
6. Repeat steps 3 and 4 for the Password and Confirm Password fields.
7. In the Permissions list, select **access permissions for the user**.
8. Tap **Accept**.

## Changing a user account password or permissions

You can update the password or access permissions of a user account.

1. On the touch panel controller (TPC), *log on to the projector* (on page 18) with administrator or service permissions.
2. Tap **Menu > Administrator Setup > User Accounts**.
3. From the Username list, tap a user name.
4. Tap **Edit**.
5. Change the password or the access permissions.
6. Tap **Accept**.

## Deleting a user account

You can delete a user account when it is no longer needed.

1. On the touch panel controller (TPC), *log on to the projector* (on page 18) with administrator or service permissions.
2. Tap **Menu > Administrator Setup > User Accounts**.
3. From the Username list, tap a user name.
4. Tap **Delete**.
5. Tap **Yes**.

# Backing up, restoring, and upgrading projector files

Learn how to manage projector files.

## Adding an upgrade file

You can add an upgrade file to the projector.

1. On the touch panel controller (TPC), *log on to the projector* (on page 18) with administrator or service permissions.
2. Tap **Menu** > **Administrator Setup** > **Upgrade**.
3. Tap **Upload**.
4. In the Drive Letter list, select the location of the upgrade file.
5. In the Folder list, browse to the location of the upgrade file.
6. Tap the upgrade file and then tap **Open**.

## Removing an upgrade file

You can remove an upgrade file if it is not required.

1. On the touch panel controller (TPC), *log on to the projector* (on page 18) with administrator or service permissions.
2. Tap **Menu** > **Administrator Setup** > **Upgrade**.
3. In the Available Upgrade Files list, tap an upgrade file.
4. Tap **Remove**.

## Installing an upgrade file

Complete the following procedure to install an upgrade file.

1. On the touch panel controller (TPC), *log on to the projector* (on page 18) with administrator or service permissions.

2. Tap **Menu > Administrator Setup > Upgrade.**
3. In the Available Upgrade Files list, tap an upgrade file.
4. Tap **Next.**
5. In the Component list, tap a component.
6. Select one of these options:

Option	Description
Upgrade Different Components Only	Upgrades system components that are newer or older than the currently installed version.
ICP Only Force Install	Forces an ICP install regardless of what current version is installed.
Force Upgrade All	Upgrades all components in the upgrade package.
Factory Install	Removes all configurations and upgrades all components.

7. Tap **Next.**

## Backing up projector settings and information

You can back up the current projector settings in case you must restore these settings at a later time.

1. On the touch panel controller (TPC), *log on to the projector* (on page 18) with service permissions.
2. Tap **Menu > Service Setup > File Management.**
3. Tap **Backup.**

## Restoring a file

You can restore configuration, preference, channel, user, and ICP files.

1. On the touch panel controller (TPC), *log on to the projector* (on page 18) with service permissions.
2. Tap **Menu > Service Setup > File Management.**
3. To the right of the **File to restore** field, tap **Browse.**
4. In the Drive Letter list, select the location of the upgrade file.
5. In the Folder list, browse to the location of the upgrade file.
6. Tap the upgrade file and then tap **Open.**
7. In the Select type list, select the type of file to restore.
8. Tap **Restore.**
9. Tap **Yes.**

## Restoring factory default settings

You can restore configuration, reference, channel, and user files.

1. On the touch panel controller (TPC), *log on to the projector* (on page 18) with service permissions.
2. Tap **Menu > Service Setup > File Management**.
3. In the Select type list, select a file type to restore.
4. Tap **Reset Defaults**.
5. Tap **Yes**.

## Moving files to the projector

You can move files onto the projector from a USB flash drive.

1. Insert the USB flash drive into the USB port on the side of the touch panel controller (TPC).
2. Tap **Menu > Service Setup > File Maintenance**.
3. In the File Type list, select a file type.
4. Tap and drag a file from the **TPC Files** pane to the **Projector Files** pane.

## Deleting projector files

You can delete files when required.

1. On the touch panel controller (TPC), tap **Menu > Service Setup > File Maintenance**.
2. In the File Type list, select a file type.
3. Tap and drag a file from the **Projector Files** pane to the trash can icon.
4. Tap **Yes**.

# Test patterns

Use the projector to assist with configuration of the projector and to diagnose any issues that may occur.

## Adding or removing preferred test patterns

Add or remove test patterns from the Preferred Test Patterns pane.

1. On the touch panel controller (TPC), *log on to the projector* (on page 18) with administrator or service permissions.
2. Tap **Menu** > **Administrator Setup** > **Preferred Test Pattern Setup**.
3. To add a test pattern to the Preferred Test Pattern pane, tap and drag a test pattern from the Unselected Patterns list to User Selected pane.
4. To remove a test pattern from the Preferred Test Pattern pane, tap and drag a test pattern from the User Selected pane to the recycle bin in the bottom right corner.

## Turning a test pattern on or off

Test patterns are available to assist with the configuration of the projector and to diagnose any issues that may occur.

1. In the touch panel controller (TPC) task bar, tap the **Test Pattern** icon:  

2. Tap **All Test Patterns**.
3. To turn a test pattern on, in the Preferred Test Patterns pane, tap the test pattern.
4. To turn the test pattern off, tap **Test Pattern Off**.

## Displaying a full screen test pattern

Some test patterns fill the screen instead of a portion of it.

1. In the touch panel controller (TPC) task bar, tap the **Test Pattern** icon:  

2. Tap **All Test Patterns**.
3. To turn the test pattern on, in the Preferred Test Patterns pane, double-tap the test pattern.
4. Tap **Full Screen (Ignore screen file settings)**.



# Viewing 3D content

Configure the hardware and software for viewing 3D presentations.

## Display requirements

To display 3D images with the CP2208 projector, you require the following items.

- A 3D hardware system:
  - Pi-Cell polarizer for display on a screen that has a silver polarization-preserving surface for use with passive glasses (RealD).
  - Rotating polarizing wheel (external) with passive circular polarizing glasses (MasterImage). Requires a silver screen.
  - IR emitter for controlling the left eye/right eye gating (switching) of active glasses (Xpand).
  - Dual projector 3D - passive glasses (circular or linear). Requires a silver screen.
- A 3D connection cable.
- Power supply for your synchronization output device. The 3D sync port can power output devices.

## 3D sync terminal pin map

The 3D Sync terminal is a 15-pin D-sub connector (female) located on the projector communications panel.

This table lists the control functions available through the 3D connector.

Pin	Signal name	Direction	Description
1	+12V	Out	Power to 3D device. Maximum 1A (total between both +12V pins).
2	GND	/	Ground
3	GND	/	Ground
4	RS232_RX	In	Data to projector from 3D device. 1200 Baud, 8 bits, no parity. Currently unsupported.

Pin	Signal name	Direction	Description
5	RS232_TX	Out	Data to projector from 3D device. 1200 Baud, 8 bits, no parity. Currently unsupported.
6	CONN_3D_MODE+	Out	SYNC from projector. To projector GPO collector. Compatible with current projector GPIO requirements and restrictions. (24VDC max, 50mA max) 3D ON = Hi logic level = O/P transistor ON 3D OFF = Low logic level = O/P transistor OFF
7	CONN_SYNC+	Out	SYNC from projector. To projector GPO collector. Compatible with current projector GPIO requirements and restrictions. (24VDC max, 50mA max)
8	3D_INPUT_REFERENCE+	In	3D L/R Input Reference (P) (Voltage Limit: 2 VDC to 12VDC)
9	+12V	Out	Power to 3D system. Maximum 1A (Total between both +12V pins)
10	3D_INPUT_REFERENCE-	In	3D L/R Input Reference (N) (Voltage limit: 1.4VDC to 12VDC)
11	3D_DISPLAY_REFERENCE+	In	3D L/R Input Reference (P) (Voltage limit: 1.4VDC to 12VDC)
12	3D_DISPLAY_REFERENCE-	In	3D L/R Input Reference (P) (Voltage limit: 1.4VDC to 12VDC)
13	CONN_3D_MODE-	Out	3D mode state from projector. From projector GPO emitter. Compatible with current projector GPIO requirements and restrictions. (24VDC max, 50mA max)
14	CONN_SYNC-	Out	SYNC from projector. From projector GPO emitter. Compatible with current projector GPIO requirements and restrictions. (24DC max, 50mA max)
15	Not connected		

## Setting up hardware

Use an infrared emitter to control gating in active glasses, a polarizing Z-screen (Pi-cell) with passive glasses or filter wheel with passive glasses.

	RealD Z-screen	RealD XL box	Xpand	Master image	Dual projector
Installed/ mounted components	Z-screen mounted in front of the projection lens	XL box mounted in front of the projection lens	None	Wheel installed in front of the projector	Polarizing plates in front of lenses
Silver screen	Yes	Yes	No	Yes	Yes
3D glasses	Polarizing circular glasses	Polarizing circular glasses	Active glasses	Circular polarized glasses	Polarizing circular or linear glasses

## Creating a high frame rate 3D file

Use this procedure to create 24Hz, 48Hz, and 60Hz high frame rate 3D files. These files allow you to display content with different frame rates consecutively.

1. Tap **Menu > Advanced Setup > High Frame Rate 3D File Setup**.
2. From the Current 3D File list, select a 3D frame rate file.
3. Complete these fields:

Field	Description
3D Sync Input Mode	<p>Specifies whether a specific frame of input data has left eye or right eye data.</p> <p>Select <b>Use White Line Code (true and inverted)</b> if you are using a single 3D input signal in which an embedded white line at the bottom of each frame identifies left and right, and an additional separate 3D stereo sync input at the GPIO port is not present. The bottom row of the left-eye sub-field should be pure white for the left-most 25% of the pixel row and pure black for the remainder of the row. The bottom row of the right-eye sub-field should be pure white for the left-most 75% of the pixel row and pure black for the remainder of the row.</p> <p>Select <b>Use Line Interleave for 3D source data only</b>. When specified, the ICP will de-interleave each line into the left image or right image in memory as specified. Line interleave can be used with PsF 3D data (left and right data for one field, then left and right data for second field).</p>
L/R Display Reference	Specifies which frame of eye data to display during a specific display frame. This signal is referenced to the display frame rate which is specified by the Frame Rate N:M.
Frame Rate N:M	Sets how many frames to display per number of frames that form one complete image. Increase the display frame rate to reduce flicker from your source(s).
L/R Display Sequence	Defines the frame order (L-R or R-L) required for 3D perspective. This option only has meaning when the Frame Rate factor M is equal to 2. For

Field	Description
	this case, two input frames of data are required to constitute a complete frame of image data. This parameter tells the system which frames go together to make a complete image. When using <b>Line Interleave</b> as the 3D Sync Input Mode, ensure that <b>Left (L1R1 L2R2)</b> is selected.
3D Sync Polarity	Keeps 3D stereo sync output the same as input (true) or reversed (inverted). True: 3D L/R sync output from GPO will match L/R sync input. Inverted: 3D L/R sync output from GPO will be the opposite of sync input (left = right, right = left).
Dark Time	Creates a blank time interval between left and right frames to allow for LCD shutter glasses, Z screen, or rotating 3D wheel to synchronize the output. See Dark Time and Output Delay Notes below. Values between 0 and 65535 are accepted. To enter the dark time value, tap the <b>Launch Dialog</b> icon: 
Output Delay	The non-image time in Microseconds ( $\mu$ ). Offset 3D stereo sync output in relation to dark time interval. Acceptable values are between -32768 and 32767 are accepted where a positive offset = delay and negative offset = start early. Tap <b>Launch Dialog</b> to enter the output delay value.
Phase Delay	The degree of reference between the left and right sync output. Values between -180 and 180 are accepted. Tap <b>Launch Dialog</b> to enter the phase delay value.

4. Tap **Save**.

## Editing the default 3D light file

For 3D images to display correctly, you must edit the default 3D light file to match the specifications of your 3D hardware.

1. Tap **Menu > Advanced Setup > Light Power / LiteLOC™ Setup**.
2. From the Current Light File list, select **Default 3D**.
3. In the Power % field, set the brightness percentage for the light source.
4. Tap **Save**.

## Defining a measured color gamut data file

For 3D images to display correctly, you must define an MCGD file to match the specifications of your 3D hardware.

1. Turn the light on and allow it to operate for 20 minutes.
2. Tap **Menu > Advanced Setup > MCGD File Setup**.
3. Hold a pair of 3D glasses in front of the light meter to determine the new x and y color coordinates for Red, Green, Blue, and White.  
Use the same light path that you use to display a show.

4. In the Red, Green, Blue and White fields, enter the x and y values.
5. Tap **Save As**.
6. In the File Name field, enter **3D Onsite**.
7. Tap **Save**.

## Editing the 3D flat 1998 x 1080 channel

Edit the projector settings in the 3D channels to ensure the 3D content is displayed correctly.

1. Tap **Menu** > **Channel Setup**.
2. From the Channel Name list, select **3D Flat 1998x1080**.
3. In the left pane, tap **Config 1** and edit these settings:
  - a) From the Input list, select **292-Dual**.
  - b) From the Data Format list, select **YCrCb 4:2:2 10 bits x2**.
  - c) From the Source File list, select **1998x1080 1.85 Flat**.
  - d) From the Screen File list, select **Flat**.
4. In the left pane, tap **Config 2** and edit these settings:
  - a) From the Measured Color list, select **3D Onsite**.  
If this option is not available, *define a measured color gamut data file* (on page 52).
  - b) From the Target Color list, select **DC28\_DCIXYZE\_314\_351**.
  - c) From the Color Space list, select **YCxCz Inverse ICT**.
  - d) From the Gamma list, select **Gamma 2.6**.
  - e) From the LUT-CLUT list, select **Linear\_9x9x9**.
5. In the left pane, tap **3D Control** and edit these settings:
  - a) From the 3D Sync Input Mode list, select **Line Interleave**.
  - b) From the Frame Rate N:M list, select a frame rate suitable to your 3D system.  
For example, for 24Hz 3D, select 2:2, 4:2, or 6:2 for single, double, and triple flash.
  - c) From the L/R Display Sequence list, select **Left (L1R1 L2R2)**.
  - d) From the 3D Sync Polarity list, select **True**.
  - e) In the Dark Time field, enter **430** or a value appropriate for your 3D hardware.
  - f) In the Output Delay field, enter **-120** or a value appropriate for your 3D hardware.
  - g) In the Phase Delay field, enter **0** or a value appropriate for your 3D hardware.

## Editing the 3D scope 2048 x 858 channel

Edit the projector settings in the 3D channels to ensure the 3D content is displayed correctly.

1. Tap **Menu** > **Channel Setup**.
2. From the Channel Name list, select **3D Scope 2048x858**.
3. In the left pane, tap **Config 1** and edit these settings:
  - a) From the Input list, select **292-Dual**.

- b) From the Data Format list, select **YCrCb 4:2:2 10 bits x2**.
- c) From the Source File list, select **2048x858 2.39 Scope**.
- d) From the Screen File list, select **Scope**.
- 4. In the left pane, tap **Config 2** and edit these settings:
  - a) From the Measured Color list, select **3D Onsite**.  
If this option is not available, *define a measured color gamut data file* (on page 52).
  - b) From the Target Color list, select **DC28\_DCIXYZE\_314\_351**.
  - c) From the Color Space list, select **YxCz Inverse ICT**.
  - d) From the Gamma list, select **Gamma 2.6**.
  - e) From the LUT-CLUT list, select **Linear\_9x9x9**.
- 5. In the left pane, tap **3D Control** and edit these settings:
  - a) From the 3D Sync Input Mode list, select **Line Interleave**.
  - b) From the Frame Rate N:M list, select **6:2**.
  - c) From the L/R Display Sequence list, select **Left (L1R1 L2R2)**.
  - d) From the 3D Sync Polarity list, select **True**.
  - e) In the Dark Time field, enter **430** or a value appropriate for your 3D hardware.
  - f) In the Output Delay field, enter **-120** or a value appropriate for your 3D hardware.
  - g) In the Phase Delay field, enter **0** or a value appropriate for your 3D hardware.

## Displaying 3D diagnostic test patterns

You can use 3D test patterns to verify your 3D hardware is functioning correctly.

1. Tap **Menu > Channel Setup**.
2. From the Channel Name list, select a 3D channel.
3. Tap **3D Test Patterns**.
4. Tap a test pattern.
5. Put on a pair of 3D glasses.
6. Look at the on-screen image, and then close your left eye and look at the image through your right eye. Switch when the image alternates.

3D Test Pattern	Action
RGB-12bit -3D Dynamic Range	Alternates between two images.
RGB-12bit-3D Four Quadrant	Alternates between two images.
RGB-12bit-3D Full White	Alternates between two 100% white images.
RGB-12bit-3D Half Descending	Alternates between four images.
RGB-12bit-3D Horizontal Ramp	Alternates between two horizontal ramp images.
RGB-12bit-3D L-Pattern	Alternates between two images.

## Verifying 3D cinema content

Check the 3D content to verify that it displays correctly.

1. Put on a pair of 3D glasses.
2. Play the 3D content.
3. Verify the left and right eye display correctly.
4. If the image is reversed:
  - a) Tap **Menu** > **Channel Setup** on the TPC.
  - b) From the Channel Name list, select a 3D channel.
  - c) From the 3D Sync Polarity list, select **Inverted**.

## Troubleshooting 3D

In addition to the information provided in the troubleshooting topics, we recommend that you consult the documentation provided with your 3D hardware to help resolve issues.

### Reversed 3D effect (Pseudo 3D)

The 3D effect looks reversed or broken up.

#### Resolution

1. Put your 3D glasses on upside down so the left lens is over your right eye and the right lens is over your right eye.
2. If the image appears correct:
  - a. Tap **Menu** > **Channel Setup**.
  - b. From the Channel Name list, select a 3D channel.
  - c. From the 3D Sync Polarity list, select **Inverted** or **True**.
3. If you see image breakup:
  - a. Tap **Menu** > **Channel Setup**.
  - b. From the Channel Name list, select a 3D channel.
  - c. In the left pane, tap **3D Control**.
  - d. Lower the Dark Time field value to match the values of your 3D system.

### Image is too dark

The light source power for 3D content is typically twice as high as for 2D content except when you are using a RealD XL device.

#### Resolution

1. Tap **Menu** > **Advanced Setup** > **Light Power/LiteLOC™ Setup**.
2. Increase the value in the Power % field.

## No 3D effect

When viewing 3D content, I cannot see the 3D effect.

### Resolution

1. Tap **Menu** > **Channel Setup**.
2. From the Channel Name list, select a 3D channel.
3. In the left pane, tap **3D Control**.
4. Verify that **Enable 3D** is selected.

## Ghosting / cross-talk

When viewing 3D content, I see blurred edges and misaligned images.

### Resolution

1. Tap **Menu** > **Channel Setup**.
2. From the Channel Name list, select a 3D channel.
3. In the left pane, tap **3D Control**.
4. Raise or lower the Dark Time field value.
5. Raise or lower the Output Delay field value to match the values of your 3D system.

## Motion artifacts

When viewing 3D content, I see motion artifacts.

### Resolution

1. Tap **Menu** > **Channel Setup**.
2. From the Channel Name list, select a 3D channel.
3. In the left pane, tap **3D Control**.
4. From the L/R Display Sequence list, select **Left (L1R1 L2R2)**.

## Disturbing flashing in one eye

When viewing 3D content, I see distracting flashing in one eye.

### Resolution

1. Tap **Menu** > **Channel Setup**.
2. From the Channel Name list, select a 3D channel.
3. In the left pane, tap **3D Control**.
4. From the L/R Display Sequence list, select **Left (L1R1 L2R2)**.



# Troubleshooting

The following topics cover common projector issues and their solutions. If an issue cannot be resolved, contact a Christie qualified technician.

## Projector functionality

The following topics cover common projector issues and their solutions.

### Projector does not turn on

When I attempt to power on the projector, it does not turn on.

#### Resolution

- Verify the power cord is connected to the projector and the AC power supply correctly and the input selector switch is in the correct position.
- Verify the wall circuit breaker is on. If there is a problem with the wall circuit breaker turning off, contact a certified electrician.
- Verify the touch panel controller (TPC) is on and the LEDs on the input panel are illuminated. If the TPC is off and there are no LEDs illuminated, verify the connected AC outlet is working and the TPC is connected to the projector. If the AC outlet is working and the TPC is connected to the projector, contact Christie support.
- If the TPC is connected to the projector and the LEDs on the input panel are illuminated on the TPC, verify that the Operational Status region of the Main panel does not indicate a PIB failure.

### Cannot establish communication with projector

The input devices cannot communicate with the projector.

#### Resolution

- Verify all input devices have the same subnet mask and gateway, and unique IP addresses.

## Display issues

The following topics cover common display issues and their solutions.

### Flicker, shadows, or dimness

The projected image flickers, contains shadows, or is dim.

#### Resolution

- Verify that the douser is open.
- Tap **Menu > Advanced Setup > Light Power/LiteLOC Setup**. Monitor the **Power %** field to determine if the power is consistent or if it varies. Increase the power.
- A fold mirror, light module, or integrator rod misalignment could exist. Contact your Christie qualified service technician to resolve the issue.

### Blank screen with no display of cinema image

When the projector is turned on, nothing is displayed.

#### Resolution

- Ensure the lens cap is not on either end of the lens.
- Ensure the light module is on.
- Confirm all power connections are still OK.
- Ensure the douser is **open** by verifying the state of the douser on Main panel.
- Ensure any test pattern other than the full black test pattern displays properly.
- Verify the correct display file is selected.
- For cinema connections, verify the correct port is selected.

### Severe motion artifacts

The displayed image has artifacts such as smearing and double image perception.

#### Resolution

- Verify if there is a synchronization problem with reversed 3-2 pull-down in the 60Hz-to-24Hz film-to digital conversion, and correct it at the source.

### Image is vertically stretched or squeezed

The image appears vertically stretched or squeezed into the center of the screen.

#### Resolution

## Inaccurate display colors

The colors in the image are not what I expected to see.

### Resolution

1. In the left navigation menu, tap **Channel Setup**.
2. Tap **Config 1**.
3. In the PCF list, verify that the correct value is selected
4. Tap **Config 2**.
5. In the **Color Space** field, verify that correct value is selected.

## Display is not rectangular

The shape of the display is not correct.

### Resolution

- Verify that the projector is level and the lens surface and screen are parallel to one another.
- Adjust the vertical offset of the lens mount with the vertical offset knob.
- Verify that the settings for the screen file are correct by tapping **Menu > Advanced Setup > Screen File Setup**.

## Display is noisy

The projected image contains noise.

### Resolution

- Adjust the input source pixel tracking, phase, and filter.
- Verify that the cables connecting the input device to the projector meet the minimum requirements and are undamaged.
- Add signal amplification or conditioning if the distance between the input device and the projector exceeds 25 feet.
- Turn the projector off and then on again.

## Display has suddenly frozen

The image on the screen has frozen.

### Resolution

- Turn off the projector and unplug the power cord from the power source.
- Plug the projector power cord into a power source and turn the projector on.

## Projector does not display alternate content

The projector is on, but alternate content does not display

### Resolution

- Verify that the lens cover is removed from the lens.
- Verify that the light module is on.
- Verify that the douser is open.
- On the projector touch panel, tap the **light on** icon.
- Verify that the correct channel is selected and the settings are correct by tapping **Menu > Channel Setup**.
- Verify that an active source is connected properly. Check the cable connections and make sure the alternative source is selected.
- Verify that you can select test patterns. If you can, check your source connections again.

## Display is unstable

The display is jittery or unstable.

### Resolution

- Verify that the input device is connected properly. If the input device is not connected properly, the projector repeatedly attempts to display an image.
- The horizontal or vertical scan frequency of the input signal may be out of range for the projector.
- The sync signal may be inadequate. Correct the source problem.

## Portions of the display are cut off

Parts of the image do not appear on the screen.

### Resolution

If you have resized the image, adjust the resizing settings until the entire image is visible and centered.

## Inconsistent picture quality

The quality of the projected image keeps changing.

### Resolution

Verify the quality of the signal from the input source.

## Touch panel controller issues

The following topics cover common touch panel controller issues and their solutions.

### Touch panel controller fails to initialize

The touch panel controller does not start up successfully.

#### Resolution

- Restart the projector.
- Make sure the compact flash on the left side is installed correctly.
- Make sure the touch panel controller is connected to the projector.

### Button presses on the touch panel controller are not registering correctly

Pressing buttons on the touch panel controller behave as if a different button was pressed.

#### Details

If the location of button presses on the screen are not interpreted correctly, the TPC screen may need recalibrating.

#### Resolution

1. Tap **Menu > Administrator Setup > Preferences**.
2. Tap **Calibrate Screen** and follow the onscreen instructions.

# Specifications

Learn about the product specifications. Due to continuing research, specifications are subject to change without notice.

## Physical specifications

Learn the dimensions and weight of the projector.

Item	Description
Size (L x W x H) (without the lens, and with the feet at minimum length)	828 mm (32.6 inches) x 822 mm (32.4 inches) x 414 mm (16.3 inches)
Weight (with lens removed)	73 kg (161 lbs)
Shipping weight	101 kg (223 lbs)
Touch panel controller (W x H x D)	195 mm (7.68 inches) x 148 mm (5.83 inches) x 44.4 mm (1.75 inches)

## Power specifications

Learn the power requirements for the projector.

### AC input (A)

Item	Description
Voltage range	200 - 240 VAC
Line frequency	50/60 Hz
Inrush current	100 A maximum (at 240 VAC)
Current consumption	10 A maximum (at 200 VAC)
Power consumption	2000 W maximum
Current rating of AC input	IEC-320-C19/16 A of IEC inlet

### UPS AC input (B)

Item	Description
Activation	Discrete switch
UPS inlet connector (rating for powering main electronics)	IEC-320-C13/10 A, 240 VAC
UPS type	Universal 100-240 VAC
Line frequency	50/60 Hz
Inrush current	100 A maximum (at 240 VAC)
Current consumption	3 A maximum (at 100 VAC)
Power consumption	300 W maximum

## Environmental specifications

Learn about the environment requirements for the projector while operating and not operating.

### Operating environment

Item	Description
Temperature	15°C to 35°C (59°F to 95°F) from 0 - 500 meters, 15°C to 28°C (59°F to 82°F) from 500 - 3000 meters
Humidity (non-condensing)	20% to 85%
Altitude	0 - 3000 meters

### Non-operating environment

Item	Description
Temperature	-20°C to 60°C (-4°F to 140°F)
Humidity (non-condensing)	0% to 85%
Altitude	0 - 15000 meters

## Display specifications

Learn the display specifications of the projector.

### Panel resolution and refresh rate

Pixel format (H x V square pixels)	2048 x 1080
Processing path	23.97 - 240Hz

**Achievable contrast ratio**

400:1 ANSI
1700:1 Full Frame ON/OFF

**Color and gray scale**

Displayable colors	35.2 trillion
Gray scale resolution	45 bits total linear, 15 bits per RGB component

**White point**

<b>Nominal White (full white, after calibration to telecine mode, theaters)</b>	
x	$x = 0.314 \pm 0.006$
y	$y = 0.351 \pm 0.006$

**Gamma**

Theater (nominal)	$2.6 \pm 5\%$
-------------------	---------------

## Control signal compatibility

Learn the control signal compatibility for the projector.

**Ethernet port**

Interface	10Base-T/100-Base-TX
Connector	Female RJ-45
Bit Rate	10 Mbps or 100 Mbps half and full duplex

**RS232-PIBS1**

Interface	TIA-232
Connector	9-pin subminiature D, female
Bit Rate	115,200 (default) bps
Flow Control	Hardware (RTS/CTS)
Data Format	1 start bit, 8 data bits, 1 stop bit, no parity
Communication Protocol	Christie Serial Protocol



### 3D terminal

Interface	Proprietary 3D connector
Connector	15-pin subminiature D, female
Bit Rate	1,200 bps
Data Format	1 start bit, 8 data bits, 1 stop bit, no parity
Communication Protocol	RS232 and GPIO

### Related information

*3D sync terminal pin map* (on page 49)

## Touch panel controller specifications

Learn the specifications of the touch panel controller.

Type of Display	Color VGA TFT LCD, backlit
Display Size	144.8 mm (5.7 inches) diagonal
Display Resolution (H x V pixels)	640 x 480
Maximum Dimensions (W x H x D)	195 mm x 148 mm x 44.4 mm
Integrated Operating System	Microsoft Windows® XPe
Communication Interface with Projector	10/1000Base-T Ethernet
Power Requirement	1.02 A maximum at 24 VDC (+/- 10%)
Interface Connector	12-pin Circular connector (push-pull)

## Accessories

Learn what accessories are available for the projector.

### Standard (sold with product)

- Touch panel controller (TPC) with interface cable
- Product Safety Guide (with USB containing additional technical documentation)
- Power cord
- Air filters

### Zoom lenses

- 1.2-1.72 .69" DLPCine Zoom (108-494108-XX)
- 1.33-2.1 .69" DLPCine Zoom (108-495109-XX)
- 1.62-2.7 .69" DLPCine Zoom (108-496100-XX)

- 2.09-3.9 .69" DLPCine Zoom (108-497101-XX)

### Miscellaneous

- Rack stand (108-416102-XX)
- Ball joint and arm assembly (159-101103-XX)

## Regulatory

This product conforms to the following regulations related to product safety, environmental requirements and electromagnetic compatibility (EMC).

### Safety

- CAN/CSA C22.2 No. 60950-1
- ANSI/UL 60950-1
- IEC 60950-1
- EN 60950-1
- IEC 60825
- IEC 62471-5

## Electro-magnetic compatibility

### Emissions

- FCC CFR47, Part 15, Subpart B, Class A
- CAN ICES-3 (A) / NMB-3 (A)
- CISPR 22/EN 55022, Class A

### Immunity

- CISPR 24/EN55024

## Environmental

EU Directive (2011/65/EU) on the restriction of the uses of certain hazardous substances (RoHS) in electrical and electronic equipment and the applicable official amendment(s).

EU Regulation (EC) No. 1907/2006 on the registration, evaluation, authorization and restriction of chemicals (REACH) and the applicable official amendment(s).

EU Directive (2012/19/EU) on waste and electrical and electronic equipment (WEEE) and the applicable official amendment(s).

China Ministry of Information Industry (along with 7 other Government Agencies) Order No.32 (01/2016) on the control of pollution caused by electronic information products, hazardous substances concentration limits (GB/T 26572 - 2011), and the applicable product marking requirement (SJ/T 11364 - 2014)

#### Corporate offices

---

USA – Cypress  
ph: 714-236-8610

Canada – Kitchener  
ph: 519-744-8005

#### Consultant offices

---

Italy  
ph: +39 (0) 2 9902 1161

#### Worldwide offices

---

Australia  
ph: +61 (0) 7 3624 4888

Brazil  
ph: +55 (11) 2548 4753

China (Beijing)  
ph: +86 10 6561 0240

China (Shanghai)  
ph: +86 21 6278 7708

Eastern Europe and  
Russian Federation  
ph: +36 (0) 1 47 48 100

France  
ph: +33 (0) 1 41 21 44 04

Germany  
ph: +49 2161 664540

India  
ph: +91 (080) 6708 9999

Japan (Tokyo)  
ph: 81 3 3599 7481

Korea (Seoul)  
ph: +82 2 702 1601

Republic of South Africa  
ph: +27 (0)11 510 0094

Singapore  
ph: +65 6877-8737

Spain  
ph: +34 91 633 9990

United Arab Emirates  
ph: +971 4 3206688

United Kingdom  
ph: +44 (0) 118 977 8000