The top half of the page features a complex, abstract background of overlapping, semi-transparent blue triangles and polygons in various shades of blue, creating a dynamic, crystalline effect. This pattern transitions into a clean white background at the bottom.

Installation and Setup Guide  
020-102647-09

# Crimson Series

**CHRISTIE®**

## NOTICES

### COPYRIGHT AND TRADEMARKS

Copyright © 2023 Christie Digital Systems USA Inc. All rights reserved.

All brand names and product names are trademarks, registered trademarks or trade names of their respective holders.

### GENERAL

Every effort has been made to ensure accuracy, however in some cases changes in the products or availability could occur which may not be reflected in this document. Christie reserves the right to make changes to specifications at any time without notice. Performance specifications are typical, but may vary depending on conditions beyond Christie's control such as maintenance of the product in proper working conditions. Performance specifications are based on information available at the time of printing. Christie makes no warranty of any kind with regard to this material, including, but not limited to, implied warranties of fitness for a particular purpose. Christie will not be liable for errors contained herein or for incidental or consequential damages in connection with the performance or use of this material. Our centers of excellence for manufacturing in Kitchener, Ontario, Canada and in Shenzhen, China are ISO 9001:2015 Quality Management System-certified.

Christie is committed to making our documents free from language bias; however, we are not responsible for the language used on any linked or third-party documentation.

For the most current technical documentation and office contact information, visit <http://www.christiedigital.com>.

### Warranty

Products are warranted under Christie's standard limited warranty, the details of which are available at <https://www.christiedigital.com/help-center/warranties/> or by contacting your Christie dealer or Christie.

### PREVENTATIVE MAINTENANCE

Preventative maintenance is an important part of the continued and proper operation of your product. Failure to perform maintenance as required, and in accordance with the maintenance schedule specified by Christie, voids the warranty. For preventative maintenance schedules, refer to [www.christiedigital.com](http://www.christiedigital.com).

### REGULATORY

The product has been tested and found to comply with the limits for a Class A digital device, pursuant to Part 15 of the FCC Rules. These limits are designed to provide reasonable protection against harmful interference when the product is operated in a commercial environment. The product generates, uses, and can radiate radio frequency energy and, if not installed and used in accordance with the instruction manual, may cause harmful interference to radio communications. Operation of the product in a residential area is likely to cause harmful interference in which case the user will be required to correct the interference at the user's own expense. Changes or modifications not expressly approved by the party responsible for compliance could void the user's authority to operate the equipment

CAN ICES-3 (A) / NMB-3 (A)

이 기기는 업무용(A급)으로 전자파적합등록을 한 기기이오니 판매자 또는 사용자는 이점을 주의하시기 바라며, 가정 외의 지역에서 사용하는 것을 목적으로 합니다.

### ENVIRONMENTAL



The product is designed and manufactured with high-quality materials and components that can be recycled and reused. This symbol  means electrical and electronic equipment, at their end-of-life, should be disposed of separately from regular waste. Please dispose of the product appropriately and according to local regulations. In the European Union, separate collection systems are for used electrical and electronic products.

If printing this document, consider printing only the pages you need and select the double-sided option.

Please help us to conserve the environment we live in!

### Notation

Learn the hazard and information symbols used in the product documentation.



Danger messages indicate a hazardous situation which, if not avoided, results in death or serious injury.



Warning messages indicate a hazardous situation which, if not avoided, could result in death or serious injury.



Caution messages indicate a hazardous situation which, if not avoided, could result in minor or moderate injury.



Notice messages indicate a hazardous situation which, if not avoided, may result in equipment or property damage.



Information messages provide additional information, emphasize or provide a useful tip.

# Content

<b>Introduction</b>	<b>6</b>
Model name	6
Safety and warning guidelines	6
Installation safety and warning guidelines	7
AC power precautions	8
Laser safety precautions	8
Light intensity hazard distance	9
Product labels	11
Projector overview	13
Contact your dealer	13
Key features	14
How the projector works	14
List of components	14
Product documentation	15
Related documentation	15
<b>Installation and setup</b>	<b>16</b>
Site requirements	16
Physical operating environment	16
Power connection	16
Projector components	17
Display panel components	18
IR/wired remote keypad	19
Positioning the projector	21
Leveling the projector	22
Installing a projection lens	22
Calibrating the lens motor	24
Removing the lens	24
Connecting to AC power	25
Turning on the projector	25
Projector LED status indicators	26
Projector LED shutter indicators	27
Turning off the projector	27
Aligning the image	27

Adjusting offset. . . . .	28
Resetting the lens to home position. . . . .	28
Selecting a test pattern. . . . .	28
Aligning the boresight. . . . .	28
Optimizing the Integrator Focus and Zoom. . . . .	31
Adjusting the fold mirror. . . . .	32
Adjusting digital micromirror device (DMD) convergence. . . . .	33
Configuring Crimson Series to work with Christie Link. . . . .	34
Disposing of the product packaging. . . . .	35
<b>Connecting devices and establishing communication. . . . .</b>	<b>36</b>
IMXB ports. . . . .	36
Connecting a video source using 3G input card. . . . .	37
Connecting a video source using DVI. . . . .	37
Connecting a video source using DisplayPort. . . . .	38
Connecting a video source using HDMI. . . . .	38
Connecting a video source using HBMIC. . . . .	39
Connecting a video source using TSIC. . . . .	39
Connecting a video source using HDBaseT. . . . .	40
Selecting a video source. . . . .	40
Connecting to a computer or server. . . . .	40
Configuring the RS232 port. . . . .	41
Setting up the Ethernet. . . . .	41
<b>3D setup for Mirage projectors. . . . .</b>	<b>42</b>
3D requirements. . . . .	42
Hardware requirements. . . . .	42
Software and content requirements. . . . .	42
Active stereo 3D configuration. . . . .	43
3D system timing. . . . .	43
3D input video configurations. . . . .	43
Setting up a single projector to display 3D content. . . . .	44
Enabling 3D mode. . . . .	44
Confirming the emitter setup. . . . .	44
Configuring the projector for the 3D source. . . . .	45
Connecting devices to the 3D sync ports. . . . .	45
<b>Signal connectivity specifications for Mirage HD25 and Mirage WU25. . . . .</b>	<b>46</b>
HBMIC video formats for Mirage projectors. . . . .	46

TSIC video formats for Mirage projectors. . . . .	47
TDPIC video formats for Mirage projectors. . . . .	48
DDIC video formats for Mirage projectors. . . . .	48
THIC video formats for Mirage projectors. . . . .	49
3GIC video formats for Mirage projectors. . . . .	49
HDBase-T video formats for Mirage projectors. . . . .	50
Dual-input 3D for Mirage projectors. . . . .	50
<b>Signal connectivity specifications for Crimson HD and WU. . . . .</b>	<b>53</b>
HBMIC video formats. . . . .	53
TSIC video formats. . . . .	54
TDPIC video formats. . . . .	54
DDIC video formats. . . . .	55
THIC video formats. . . . .	55
HDBase-T video formats. . . . .	55
3GIC video formats. . . . .	56
<b>Regulatory. . . . .</b>	<b>57</b>
Safety. . . . .	57
Electro-magnetic compatibility. . . . .	57
Emissions. . . . .	57
Immunity. . . . .	57
Environmental. . . . .	58

# Introduction

This manual is intended for professionally trained operators of Christie high-brightness projection systems.



The illustrations in this document are for representation only and may not depict your projector model exactly.

Only Christie qualified technicians who are knowledgeable about the hazards associated with laser use, high-voltage, and the high temperatures generated by the projector lasers are authorized to assemble, install, and service the projector.

For complete Crimson Series product documentation and technical support, go to [www.christiedigital.com](http://www.christiedigital.com).

## Model name

- Crimson HD25
- Crimson WU25
- Crimson HD31
- Crimson WU31
- Crimson WU32
- Mirage HD25
- Mirage WU25

## Safety and warning guidelines

Read all safety and warning guidelines before installing or operating the projector.

This projector is intended for use in a non-cinema environment.

This projector must be operated in an environment that meets the operating range specification. Use only the attachments and/or accessories recommended by Christie. Use of others may result in the risk of fire, shock, or personal injury.



**Warning!** If not avoided, the following could result in death or serious injury.

- This product must be operated in an environment that meets the operating range as specified in this document.
- FIRE HAZARD! Keep hands, clothes, and all combustible material away from the concentrated light beam of the projector.
- Keep fingers and other body parts away from the moving parts in the product. Tie back long hair, and remove jewelry and loose clothing before manually adjusting the product.
- FIRE AND SHOCK HAZARD! Use only the attachments, accessories, tools, and replacement parts specified by Christie.
- Do not operate the product without a lens installed.
- Always use a lens plug when installing or moving the product. This prevents contaminants from entering the product.
- RADIATION HAZARD! Use of controls or adjustments, or performing procedures other than those specified may result in hazardous radiation exposure.



**Caution!** If not avoided, the following could result in minor or moderate injury.

- TRIP OR FIRE HAZARD! Position all cables where they cannot contact hot surfaces, be pulled, be tripped over, or damaged by persons walking on or objects rolling over the cables.

## Installation safety and warning guidelines

Read all safety and warning guidelines before installing the projector.



**Warning!** If not avoided, the following could result in death or serious injury.

- Possible hazardous optical radiation emitted from this product. (Risk group 3)
- High leakage current present when connected to IT power systems.
- Christie products must be installed and serviced by Christie qualified technicians.
- Do not operate the product without all of its covers in place.
- A minimum of four people or appropriately rated lift equipment is required to safely lift, install, or move the product.
- Always install safety straps when the frame and projector are installed overhead.
- Observe load ratings and applicable local safety codes.
- When installing the projector in portrait mode, the rigging device must have a sufficient load rating, as identified in this manual.
- Do not stack more than three projectors in landscape orientation.
- This product must be installed within a restricted access location not accessible by the general public.
- Install the product so users and the audience cannot enter the restricted area at eye level.
- Only personnel who are trained on the precautions for the restricted access location can be granted entry to the area.
- Only Christie qualified technicians are permitted to open product enclosures.



**Caution!** If not avoided, the following could result in minor or moderate injury.

- ELECTRICAL and BURN HAZARD! Use caution when accessing internal components.
- Only Christie qualified technicians are authorized to use the tools provided in the toolbox.

## AC power precautions

Read all safety and warning guidelines before connecting to AC power.



**Warning!** If not avoided, the following could result in death or serious injury.

- SHOCK HAZARD! Only use the AC power cord provided with the product or recommended by Christie.
- FIRE AND SHOCK HAZARD! Do not attempt operation unless the power cord, power socket, and power plug meet the appropriate local rating standards.
- SHOCK HAZARD! Do not attempt operation if the AC supply is not within the specified voltage and current, as specified on the license label.
- SHOCK HAZARD! The AC power cord must be inserted into an outlet with grounding.
- SHOCK HAZARD! Disconnect the product from AC before installing, moving, servicing, cleaning, removing components, or opening any enclosure.
- Install the product near an easily accessible AC receptacle.
- The appliance coupler and main power supply plug must be easily accessible for disconnecting the product from the power source.



**Caution!** If not avoided, the following could result in minor or moderate injury.

- FIRE HAZARD! Do not use a power cord, harness, or cable that appears damaged.
- FIRE OR SHOCK HAZARD! Do not overload power outlets and extension cords.
- SHOCK HAZARD! Power supply uses double pole/neutral fusing.

## Laser safety precautions

Read all safety and warning guidelines before operating the projector laser.



**Warning!** If not avoided, the following could result in death or serious injury.

- PERMANENT/TEMPORARY BLINDNESS HAZARD! No direct exposure to the beam must be permitted. Class 1 Laser Product - Risk Group 3 according to IEC 60825-1:2014 and IEC 62471-5:2015.
- LASER RADIATION HAZARD! This projector has a built-in Class 4 laser module. Never attempt to disassemble or modify the laser module.
- Possible hazardous optical radiation emitted from this product. (Risk group 3)
- Only Christie qualified technicians who are knowledgeable about the hazards associated with laser use, high-voltage, and high temperatures generated by the product are authorized to assemble, install, and service the Christie Laser Projection System.
- Do not look directly into the lens when the light source is on. The extremely high brightness can cause permanent eye damage.
- Do not operate the product without all of its covers in place.



## Light intensity hazard distance

This projector has been classified as Risk Group 3 as per the IEC 62471-5:2015 standard due to possible hazardous optical and thermal radiation being emitted.



**Warning!** If not avoided, the following could result in serious injury.

- PERMANENT/TEMPORARY BLINDNESS HAZARD! No direct exposure to the beam must be permitted. Class 1 Laser Product - Risk Group 3 according to IEC 60825-1:2014 and IEC 62471-5:2015.
- PERMANENT/TEMPORARY BLINDNESS HAZARD! Operators must control access to the beam within the hazard distance or install the product at the height that prevents exposure of spectators' eyes within the hazard distance. The hazard zone must be no lower than 3.0 meters above the floor and the horizontal clearance to the hazard zone must be a minimum 2.5 meters.
- EXTREME BRIGHTNESS! Do not place reflective objects in the product light path.

The following show the zones for ocular and skin hazard distances.

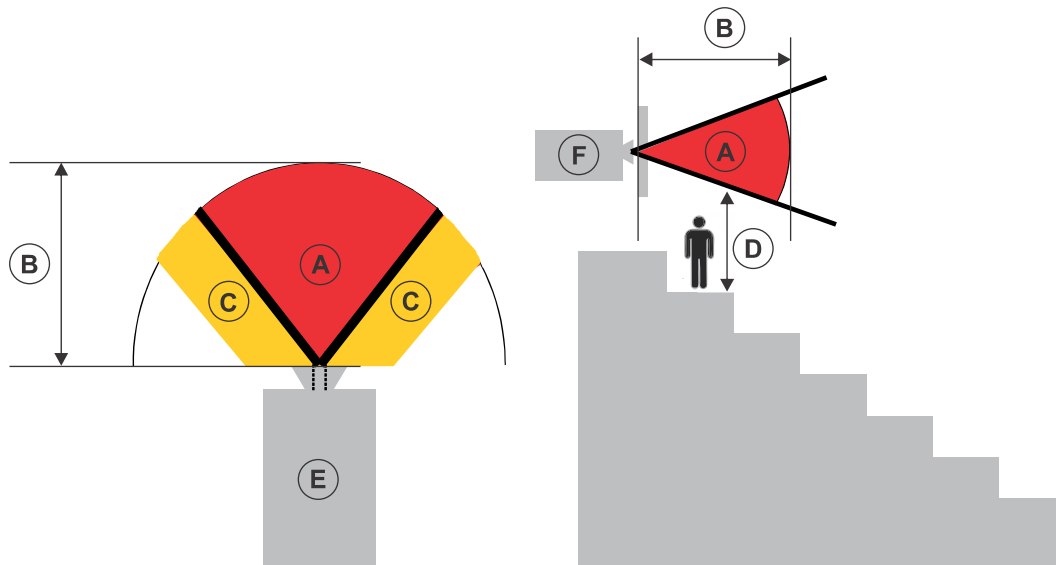

- A—Hazard zone. The region of space where the projection light from the laser-illuminated projector is above emission limits for Risk Group 2. The light intensity may cause eye damage after a momentary or brief exposure (before a person can avert their eyes away from the light source). The light may cause skin burns to occur.
- B—Hazard distance. Operators must control access to the beam within the hazard distance or install the product preventing potential exposure of the spectators' eyes from being in the hazard distance.
- C—No access zone. Horizontal clearance of the no access zone must be a minimum of 2.5 meters (8.2 feet).
- D—Vertical distance to hazard zone. The hazard zone must be no lower than 3.0 meters (9.8 feet) above the floor.  
If the vertical distance to hazard zone requirement (Zone D) is satisfied, the horizontal clearance distance (Zone C) is not needed.
- E—Represents the top view of the projector.
- F—Represents the side view of the projector.

The following table lists the hazard distance for the Christie projector lens with the zoom adjusted to its most hazardous position.

For US and international hazard distances based upon IEC 62471-5:2015, *Photobiological Safety of Lamps and Lamp Systems – Part 5: Image Projectors*.

Projection lens	Part number	Hazard distance (m)	
		Crimson/Mirage 25K	Crimson 31K/32K
0.37:1 HD ILS	118-131106-XX	1.0	1.0
0.67:1 HD ILS	118-100110-XX	1.0	1.0
0.8-1.16:1 HD ILS	118-130105-XX	1.0	1.2
1.1:1 HD ILS	118-100117-XX	1.0	1.2
1.16-1.49:1 HD ILS	118-100111-XX	1.0	1.6
1.4-1.8:1 HD ILS	118-100112-XX	1.1	1.9
1.8-2.6:1 HD ILS	118-100113-XX	1.8	2.7
2.6-4.1:1 HD ILS	118-100114-XX	2.3	4.5
4.1-6.9:1 HD ILS	118-100115-XX	6.3	7.6
6.9-10.4:1 HD ILS	118-100116-XX	12.6	11.2

### For Installations in the United States

The following must be in place for laser-illuminated projector installations in the United States:

- Any human access to the hazard zone, if applicable, must be restricted by barriers to enforce the no access zone.
- Permanent show installations containing Risk Group 3 laser-illuminated projectors must meet the following conditions:
  - Installed by Christie or by Christie-authorized and trained installers.  
Refer to the EXTERNAL - Laser safety awareness training (Course code: CS-ELSA-01) on the <http://www.christieuniversity.com> site.
  - Performed according to instructions provided by Christie.
  - Make sure the projection system is securely mounted or immobilized to prevent unintended movement or misalignment of the projections.
- A copy of the FDA variance approval letter must be with the operator or other responsible individual.
- Temporary show installations containing Risk Group 3 laser-illuminated projectors may be installed by Christie or sold or leased only to valid laser light show variance holders (laser light show manufacturers) for image projection applications. Such manufacturers may currently hold a valid variance for production of Class IIIb and IV laser light shows and/or for incorporation of the Risk Group 3 laser-illuminated projectors into their shows. This requirement applies also to dealers and distributors of these laser-illuminated projectors.
- For temporary installations, the FDA variance holder must maintain complete records of all show itineraries with dates, locations, operator name, and contact information clearly and completely identified.



- The Christie Laser Projection System Installation Checklist must be fully completed after the installation and sent to [lasercompliance@christiedigital.com](mailto:lasercompliance@christiedigital.com). A copy can remain on-site. This checklist can be found as a separate document in the accessory box with the manual.
- Certain US states have additional laser regulatory requirements. Contact [lasercompliance@christiedigital.com](mailto:lasercompliance@christiedigital.com) for additional regulatory requirements.

## Product labels

Learn about the labels that may be used on the product. Labels on your product may be yellow or black and white.

### General hazards

Hazard warnings also apply to accessories once they are installed in a Christie product connected to power.

Fire and Shock Hazard	
	<p>To prevent fire or shock hazards, do not expose this product to rain or moisture.</p> <p>Do not alter the power plug, overload the power outlet, or use it with extension cords.</p> <p>Do not remove the product enclosure.</p> <p>Only Christie qualified technicians are authorized to service the product.</p>
Electrical Hazard	
	<p>Risk of electric shock.</p> <p>Do not remove the product enclosure.</p> <p>Only Christie qualified technicians are authorized to service the product.</p>



**Warning!** If not avoided, the following could result in death or serious injury.



Electric shock hazard. To avoid personal injury, disconnect all power sources before performing maintenance or service.



Electrocution hazard. To avoid personal injury, always disconnect all power sources before performing maintenance or service procedures.



Voltage hazard. To avoid personal injury, always disconnect all power sources before performing maintenance or service procedures.



**Caution!** If not avoided, the following could result in minor or moderate injury.



Hot surface hazard. To avoid personal injury, allow the product to cool for the recommended cool down time before touching or handling for maintenance or service.



Burn hazard. To avoid personal injury, allow the product to cool for the recommended cool down time before handling for maintenance or service.



Moving parts hazard. To avoid personal injury, keep hands clear and loose clothing tied back.



Moving fan blades. To avoid personal injury, keep hands clear and loose clothing tied back. Always disconnect all power sources before performing maintenance or service procedures.



Cut hazard. To avoid personal injury, keep hands clear or wear protective gloves.



**Notice.** If not avoided, the following could result in property damage.



General hazard.



Not for household use.

### Mandatory action



**Caution!** If not avoided, the following could result in minor or moderate injury.



Consult the service manual.



SHOCK HAZARD! Disconnect all power sources before performing maintenance or service procedures.

### Electrical labels



Indicates the presence of a protective earth ground.

## Laser labels



FDA laser variance (US projectors only)

This product conforms with performance standards for laser products under 21 CFR Part 1040 except with respect to those characteristics authorized by Variance Number 2016-V-1838 effective on June 20, 2017.

Indicates a light hazard. Do not look directly into the lens. The extreme high brightness can cause permanent eye damage. Class 1 Laser Product - Risk Group 3 according to IEC 60825-1: 2014 and IEC 62471-5:2015

## Projector overview

Learn about the Crimson Series projector.

Crimson Series is a professional quality 3DLP® laser phosphor projector. The high-brightness Crimson Series is designed to meet the special demands found in large venues, live events, and high-usage environments. Featuring an IP5X-sealed, solid-state laser light source in a rugged and compact chassis, Crimson Series provides years of reliable and virtually maintenance-free operation. Add to this the enhanced color performance of Christie BoldColor Technology and the ultra-fast processing of Christie TruLife™ electronics making Crimson Series the go-to solution for demanding, large venue events and applications.

## Contact your dealer

Record the information about your projector and keep this information with your records to assist with the servicing of your projector. If you encounter a problem with your Christie projector, contact your dealer.

Purchase record
Dealer:
Dealer or Christie Sales/Service contact phone number:
Projector serial number: The serial number can be found on the license label located on the display panel
Purchase date:
Installation date:

Ethernet settings	
Default gateway:	
Projector IP address:	
Subnet mask:	

## Key features

Understand the important features of the projector.

- Long-life laser source of up to 20,000 hours of virtually maintenance-free operation
- Features enhanced color performance and saturation over standard laser phosphor projection with Christie BoldColor technology
- Compatible with existing suite of M and J Series fixed and zoom lenses
- Compatible with Christie Mystique for simplified design, installation, and maintenance of complex setups
- Omnidirectional operation for unrestricted design and installation flexibility
- Side access to optical adjustments
- TruLife electronics provide for ultra-fast processing up to 60 Hz
- Built-in warp and blend capabilities
- Full-color LCD display to provide information at-a-glance
- Integrated keypad control interface
- Electromechanical shutter

## How the projector works

Crimson Series accepts a variety of input signals for projection on front or rear projection screens, typical in commercial or other large screen applications.

High-brightness light is generated by a laser phosphor system, then modulated by three Digital Micromirror Device (DMD) panels responding to incoming data streams of digitized red, green and blue color information. As these digital streams flow from the source, light from the corresponding “on” pixels of each panel is reflected, converged and then projected to the screen through one or more projection lenses, where all pixel reflections are superimposed in sharp full-color images.

## List of components

Verify all components were received with the projector.

- Power cord for full brightness
- Power cord for limited power
- IR remote keypad

## Product documentation

For installation, setup, and user information, see the product documentation available on the Christie Digital Systems USA Inc. website. Read all instructions before using or servicing this product.

### Crimson HD25, Crimson WU25, Crimson HD31, Crimson WU31, Crimson WU32

1. Access the documentation from the Christie website:
  - Go to this URL:[bit.ly/2nOpICa](https://bit.ly/2nOpICa).
  - Scan the QR code using a QR code reader app on a smartphone or tablet.

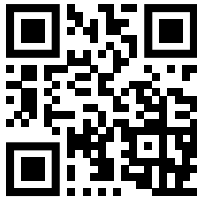

2. On the product page, select the model and switch to the **Downloads** tab.

### Mirage HD25, Mirage WU25

1. Access the documentation from the Christie website:
  - Go to this URL:[bit.ly/2C6H4HZ](https://bit.ly/2C6H4HZ).
  - Scan the QR code using a QR code reader app on a smartphone or tablet.



2. On the product page, select the model and switch to the **Downloads** tab.

## Related documentation

Additional information on the projector is available in the following documents.

- *Crimson Series User Guide (P/N: 020-102649-XX)*
- *Crimson Series Product Safety Guide (P/N: 020-102648-XX)*
- *Crimson Series Specifications Guide (P/N: 020-102724-XX)*
- *Crimson Series Service Guide (P/N: 020-102733-XX)*
- *Crimson Series Serial Commands Guide (P/N: 020-102660-XX)*
- *Crimson Series Status System Guide (P/N: 020-102661-XX)*

# Installation and setup

Learn how to install, connect, and optimize the projector display.

## Site requirements

To safely install and operate the projector, the installation location must have restricted access for authorized personnel only and meet these minimum requirements.

### Physical operating environment

Provides specifications for the operating environment.

- Crimson and Mirage HD25/WU25: Ambient temperature (operating) 5 to 40°C (41 to 104°F) up to 457.2 m (1500 feet)
- Crimson HD31/WU31/WU32: Ambient temperature (operating) 5 to 40°C (41 to 104°F) up to 304.8 m (1000 feet)
- Humidity (non-condensing) 10 to 80%
- Operating altitude: 3,000 m (10,000 feet) maximum at 5 to 25°C (41 to 77°F) ambient

### Power connection

The projector uses an innovative dual AC inlet power system that offers two power modes.

To operate at full brightness, power the projector using AC Input 1 if the appropriate high power source is available. To operate in limited power mode, power the projector using standard lower power sources using AC Input 2. A different power cord is provided for each power source. A 20 A rated wall breaker is required at the installation when using Input 1. A 15 A rated wall breaker is required at the installation when using Input 2.



# Projector components

Identify the main components of the projector.

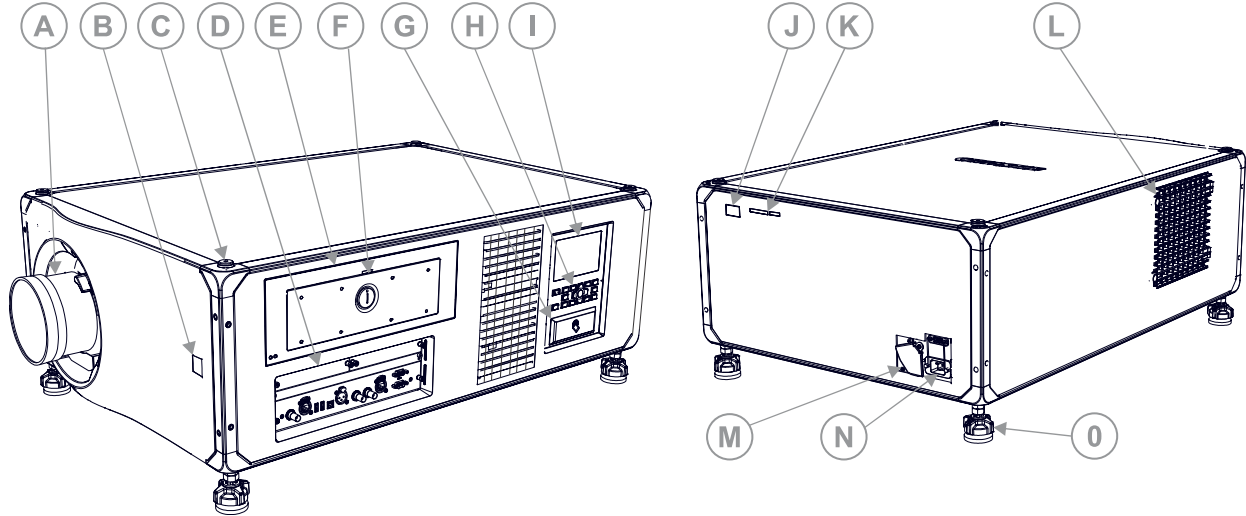

ID	Component	Description
A	Projection lens	A variety of lenses can be used with the projector. Available lenses are listed in the <i>Crimson and Mirage Specifications Guide (P/N: 020-102724-XX)</i> .
B	Front IR	Receives transmissions from the IR remote.
C	Mounting and rigging holes.	M12 x 1.75 holes for projector feet installation and offer mounting and rigging points. Four holes located on the top, and four located on the bottom.
D	Communication and input panel	Connects media sources to either the ports on the option cards or the IMXB.
E	Service compartment	Access to fold mirror, optical zoom/focus, and digital micromirror device (DMD) convergence adjustments.
F	Tool box	Provides tools for Christie qualified technicians.
G	Christie TAP	Enables Android devices to communicate with the projector using near field communication.
H	Keypad interface	Controls the projector.
I	Display panel	Displays the projector menus and status.
J	Rear IR	Receives transmissions from the IR remote.
K	LED and shutter LED status indicator	Indicates power status and shutter status.
L	Air Filter door	Provides access to the air filter.
M	AC Input 2: limited power	For use in limited power mode.
N	AC Input 1: full power	For use in full power mode.

ID	Component	Description
O	Adjustable feet	Raise or lower these feet when positioning the projector to make sure it is level on all sides so the displayed image appears rectangular without any keystone.

## Display panel components

Identify the main components of the display panel (also known as the home page).

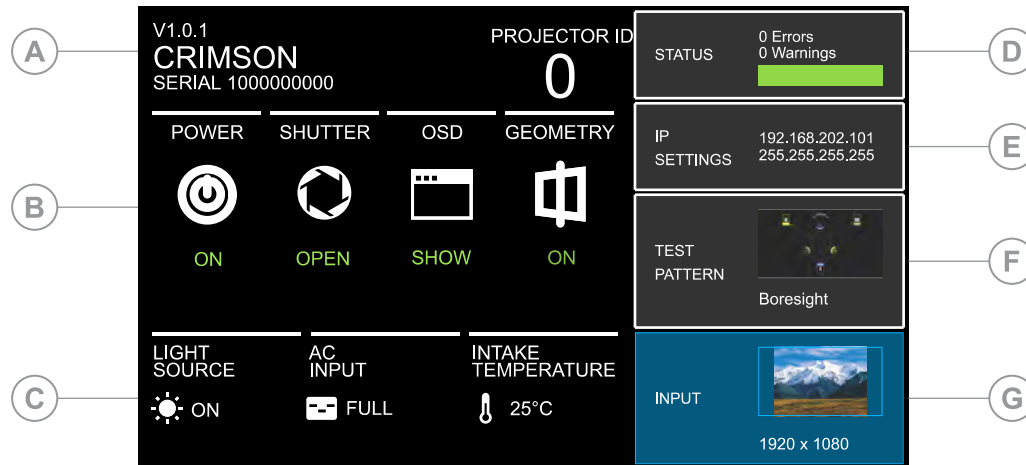

ID	Component	Description
A	Projector Information	Provides information about the projector such as the projector name, serial number, software version, and projector ID.
B	Projector and Component Controls	Indicates the states of the projector and its components.
C	Power and Temperature	Indicates the light source mode, power mode, and intake temperature.
D	Status	Contains information about the health of the projector including the number of warnings and errors. Provides access to the status system.
E	IP Settings	Displays the IP address and subnet values. Provides access to changing the IP settings.
F	Test Pattern	Displays the currently selected test pattern. If no test pattern is selected, Off is displayed. Provides access to the list of test patterns.
G	Input	Displays the signal for the currently selected input. Provides access to the list of input signals.

## IR/wired remote keypad

The IR/wired remote keypad controls the projector by way of either wireless communications from a battery-powered infrared (IR) transmitter or a wired interface.

To use the IR remote, direct the keypad toward the projector's front or rear IR sensor and select a function key. One of the two IR sensors on the projector detect the signal and relay the commands for internal processing. The remote also offers a connector for wired connections to the projector.



Only use the wired connection to the projectors for setup and service.

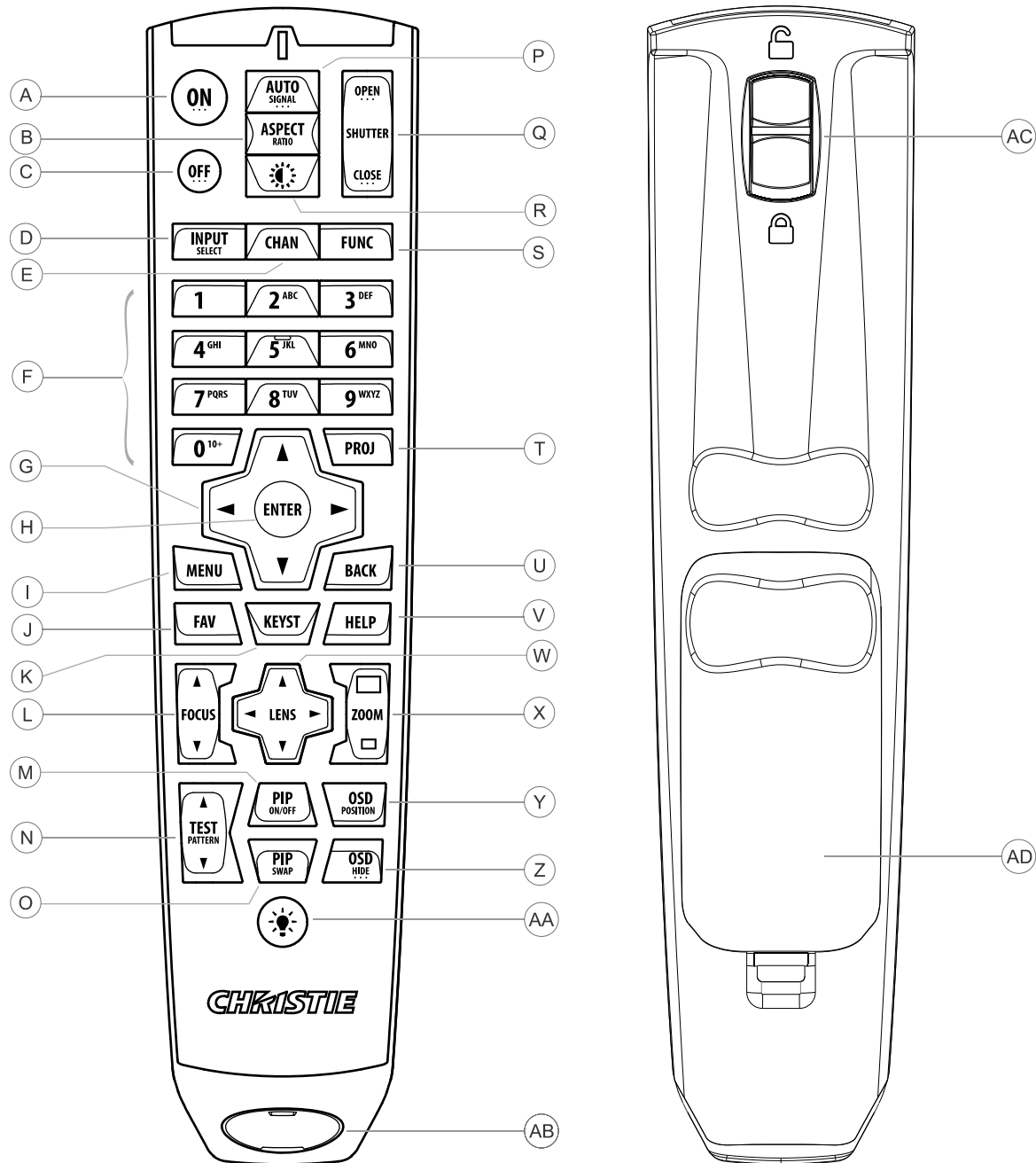

Button	Description
A	Powers on the projector light source.
B	Opens the aspect ratio dialog.
C	Turns off the light source and puts the projector in standby.
D	Selects an active or inactive input on any slot.
E	Not supported.

Button	Description
F	Enter a number, such as menu, item index or value.
G	Use the arrows to navigate within a menu or to adjust settings.
H	Selects a highlighted menu item and changes or accepts a value.
I	Toggles the menus on/off.
J	Not supported.
K	Opens the keystone dialog.
L	Adjusts the lens focus.
M	Not supported.
N	Displays a test pattern.
O	Not supported.
P	Optimizes the image automatically.
Q	Opens or closes the shutter.
R	Not supported.
S	Initiates a custom action when a number is selected.
T	Selects a projector in multi-projector installations.
U	Returns to the previous menu level or exits menus if at the top level.
V	Displays context-sensitive help.
W	Arrows adjust the lens offset.
X	Adjust the lens zoom.
Y	Opens the on-screen display position menu.
Z	Shows or hides the on-screen display menus.
AA	Turns the remote backlight on.
AB	Male 3-pin XLR connector for wired option.
AC	Lock/unlock the keypad.
AD	Battery door.

## Positioning the projector

Position the projector in relation to the screen.

For information on positioning the projector in a rigging frame, refer to the *Assembling the Precision 1 Rigging Frame (P/N: 020-102719-XX)* or *Upgrading the Boxer Rigging Frame (P/N: 020-102746-XX)* instruction sheet.

1. Position the projector with the lens perpendicular to the screen.  
Keep the projector lens as perpendicular to the screen as possible, even if significantly above the screen center. When a particularly short throw distance combines with a wide screen, you

may have to forfeit some aim and stay more perpendicular to the screen. In such cases, some lens offset can reduce the keystone distortion.

2. Center the projector with the screen.

## Leveling the projector

Use the projector feet to level the projector.

1. To adjust the vertical position of the projector, extend or retract the adjustable feet on the bottom of the projector using the adjustable knobs on the feet.

Christie recommends adjusting the feet from the side or rear of the projector and not the front to avoid exposure to the output light.

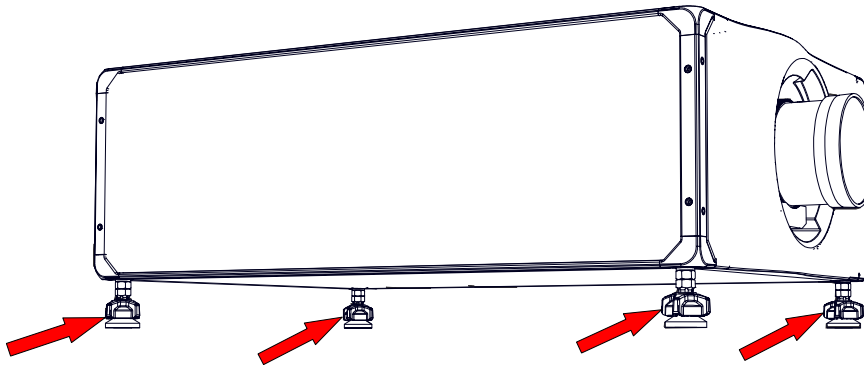

2. Once the required adjustment is made, using a wrench, tighten the lock nut against the bottom of the projector.

## Installing a projection lens

The projection lens, shipped separately from the projector, must be installed prior to setting up the projector.



**Notice.** If not avoided, the following could result in property damage.

- Always use a lens plug when installing or moving the product. This prevents contaminants from entering the product.
- Do not insert the lens into the product at an angle. This can damage the lens and the optical components inside the product.
- Always place the lens cap onto the lens when moving the projector to avoid scratching the lens.
- Remove the lens cap before turning on the product to avoid damaging the lens.

The projector includes a motorized lens mount that allows automated lens control and adjustment: vertical and horizontal offsets, zoom, and focus. The projection lens is shipped separately from the projector. Use the lens cap when transporting the lens to avoid scratching and damaging the lens, which could affect your displayed image.

- **Zoom and Focus**—Two internal lens motors allow for quick motorized adjustment of zoom and focus. Adjust zoom to fit the displayed image on the screen and adjust focus to improve the clarity of the image.
- **Lens Offset**—The motorized lens mount allows vertical and horizontal offset of the displayed image.

- **Shutter**—Sets the screen to absolute black, when in the closed state.

Do not adjust motorized lenses by hand without first setting them for manual operation; otherwise, the zoom and focus motors may be damaged.

1. Make sure the lens cap is on the lens.
2. Rotate the lens clamp to the open position.

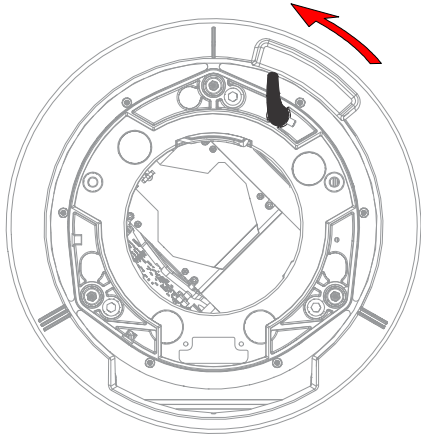

3. Align the lens interface plate with the lens mount and align the lens electrical connector with the mating connector on the lens mount.
4. Fully insert the assembly straight into the lens mount opening without turning and press with your hand as shown.

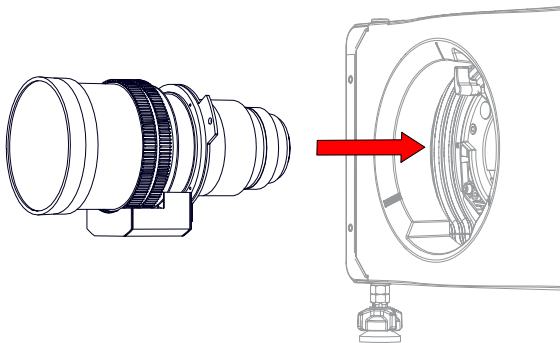

5. To lock the lens assembly in place, while holding the lens flat against the lens mount, push the lens clamp down.
6. Remove the front lens cap.
7. For added stability and safety such as motion applications, or if the projector is hoisted or installed in an overhead position, use a 5 mm hex driver to fasten the security screws provided with the lens mount or hand tighten the lens retaining screws attached to the lens.  
Christie recommends doing this for all lenses.

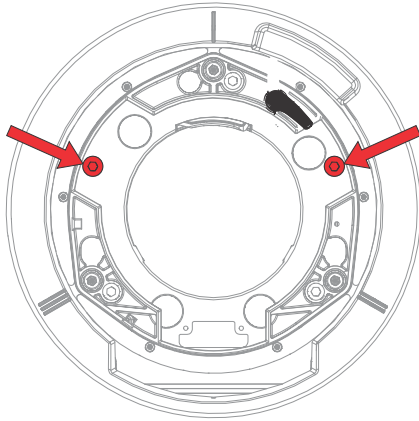

## Calibrating the lens motor

Make sure the lens motor is calibrated before using the projector.

If the lens motors are not calibrated properly, implications may include:

- Incorrect reporting of the lens motor position.
- Inability to use the full range of the lens motors.
- Lens motors traveling outside of the pre-defined keep-out area.
- Damage to the projector.

Calibrate the lens motors when any of the following conditions are met:

- After a lens change.
- After the projector is moved and/or jostled.
- After any manual adjustment is made to the zoom or focus.

To calibrate the lens:

1. Select **MENU** > **Configuration** > **Lens Settings** > **Lens Calibration**.
2. Select **Enter**.

## Removing the lens

Complete the following procedure to remove the lens.

1. Remove and retain the two security screws (for installation) from the lens mount.



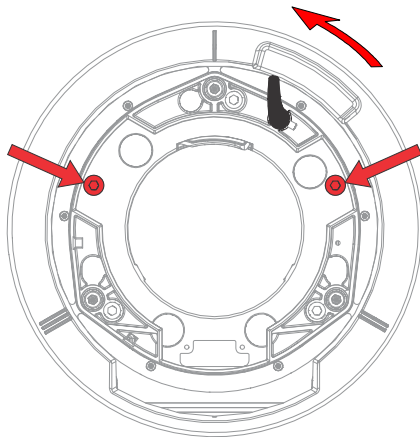

2. Rotate the lens clamp counter-clockwise to the open position.
3. Pull the lens straight out of the lens mount.

## Connecting to AC power

The Crimson Series projectors can operate in full or limited power modes, depending on the available or required AC power source.

Power mode	Functionality
Input 1: Full power	<ul style="list-style-type: none"> <li>• 20 amp rated connector IEC 320-C20</li> <li>• 200-240 VAC</li> <li>• Full brightness</li> </ul>
Input 2: Limited power	<ul style="list-style-type: none"> <li>• 15 amp rated connector IEC 320-C14</li> <li>• 100-240 VAC</li> <li>• Less brightness</li> </ul>

To connect AC power to the projector:

1. Connect AC power to the appropriate AC inlet on the projector.
2. If using full power mode, to make sure AC power cord does not fall out, pull down the safety latch and lock in place.

## Turning on the projector

When the projector AC power supply is plugged in, the power is on.



**Warning!** If not avoided, the following could result in death or serious injury.

- SHOCK HAZARD! Do not attempt operation if the AC supply is not within the specified voltage and current, as specified on the license label.

1. Plug the projector into AC power.

When plugged in, the projector automatically powers on to standby mode within 60 seconds. The display panel functionality becomes available.

- To turn on the light source using the projector keypad, select and hold the **Power**  button until a beep sounds.

To turn on the light source using the remote, select and hold the **ON** button until you a beep sounds.

**Related information**

*Power connection* (on page 16)

## Projector LED status indicators

Identify the LED state colors and meaning.

LED	State		Description
Blue	Solid	Standby	Light source is off. Video electronics are off. Projector status is OK.
	Flashing	Cool down	Projector is moving to one of the two standby states: <ul style="list-style-type: none"> <li>Light source is off and video electronics are booting up.</li> <li>Light source is off. Video electronics and light source is cooling down.</li> </ul>
Green	Solid	Light source on	Light source is on. Projector status is OK.
	Flashing	Startup	Projector is moving to light source on state. Light source is warming up. Video electronics are initializing.
Yellow	Solid	Warning in standby	Projector is in standby state. A problem exists with the projector that does not prevent it from operating.
	Flashing yellow/green	Warning during startup	Projector is in a startup state. A problem exists with the projector that does not prevent it from operating.
	Flashing	Warning with light source on	Light source is on. A problem exists with the projector that will not cause it to shut down.
	Flashing yellow/blue	Warning during cool down	Projector is in a cool down state. Light source is off. Video electronics and light source are cooling down. A problem exists with the projector that does not prevent it from operating.
Red	Solid	Error in standby	Projector is in standby. An error exists that prevents the projector from starting up.
	Flashing	Error	An error with the projector exists during startup, cool down, or when the light source is off. Projector will proceed to shut down.
Off		AC off	The AC power is off.

## Projector LED shutter indicators

Identify the shutter LED state colors and meaning.

LED	State	Description
Solid magenta	Shutter closed	The shutter is closed. In standby, the shutter is always automatically closed and the magenta light is muted.
Off	Shutter open	The shutter is open.

## Turning off the projector

When powering off in preparation for inspection or maintenance, always disconnect from AC.

- To turn off the light source using the projector keypad, select and hold the **Power**  button until a beep sounds.  
To turn off the light source using the remote, select and hold the **OFF** button until a beep sounds.  
When powering off the projector, allow the projector to complete its cool down cycle. Do not immediately unplug the projector if this can be avoided.
- To turn off power to the projector, disconnect from AC power.

## Aligning the image

Only perform image alignment after the projector is fully assembled and powered up in its final location.

Basic image alignment ensures the image reflected from the DMDs is parallel and well-centered with the lens and screen. This initial optical alignment is the foundation for optimizing images on the screen and must be completed before final boresight adjustments. Before beginning, make sure the projector is properly positioned in relation to the screen.

- Make sure the projector is positioned in the throw distance range for the particular lens.
- Display a test pattern.
- Do a quick preliminary focus and (if available) zoom adjustment with the primary lens.  
Do not worry about consistency across the image at this point, just center focus. It is good practice to have zoom adjustment and focus adjustment in the center of its range.
- Holding a piece of paper at the lens surface, adjust offsets as necessary until the image is centered within the lens perimeter. A full black field works best for this.
- If the projector is mounted off center to the screen axis, offset the lens as much as required. Aim the projector over slightly towards the center of the screen, but use caution when doing so, as too much tilt causes excessive keystone distortion.
- With a framing pattern on screen, double-check projector leveling so the top edge of the image is parallel to the top edge of the screen.

### Related information

*Selecting a test pattern* (on page 28)

## Adjusting offset

Adjust the offset to align the image on the screen. Always adjust offset before adjusting boresight.



For the best optical performance and minimal keystone, use offsets instead of aiming at the center of the image, in off-axis installations. Avoid extreme tilts or offsets. Corner vignettes on a white test pattern indicate extreme offset that should be avoided using mechanical alignment.

1. Project an image with the primary lens.
2. Select a framing test pattern.
3. Select **LENS OFFSET**.  
You can also select **MENU > Configuration > Lens Settings > Lens Offset**.
4. Use the arrows to adjust the offset to display a square image on the screen, with minimal projector aiming error.
5. To exit to the home page, select **Back**.

## Resetting the lens to home position

Set the lens offset back to the home position.

1. Select **LENS OFFSET**.  
You can also select **MENU > Configuration > Lens Settings > Lens Offset**.
2. To reset the lens to the default home position, select **Reset**.
3. To confirm the reset, select **Reset Lens Position**.

## Selecting a test pattern

Many test patterns are available to assist with the configuration of the projector and to diagnose any issues that may occur.

1. From the display panel, use the arrows to select **Test Pattern**.  
You can also select the test patterns from **MENU > Test Pattern** or pressing **N** on the IR remote.
2. Scroll through the list of test patterns.
3. Select the required test pattern.
4. To confirm your selection, select **Enter**.

## Aligning the boresight

The boresight adjustment balances the tilt of the lens mount to compensate for screen-to-projector tilt.



**Caution!** If not avoided, the following could result in minor or moderate injury.

- Do not look directly into the lens when the light source is on. The extremely high brightness can cause permanent eye damage.
1. Display the boresight test pattern.
    - a) On the remote keypad, select **Test**.  
On the built-in keypad, select the soft key that displays Test on the display panel
    - b) To cycle to Boresight, select the **Up Arrow** key.

c) Select **Enter**.

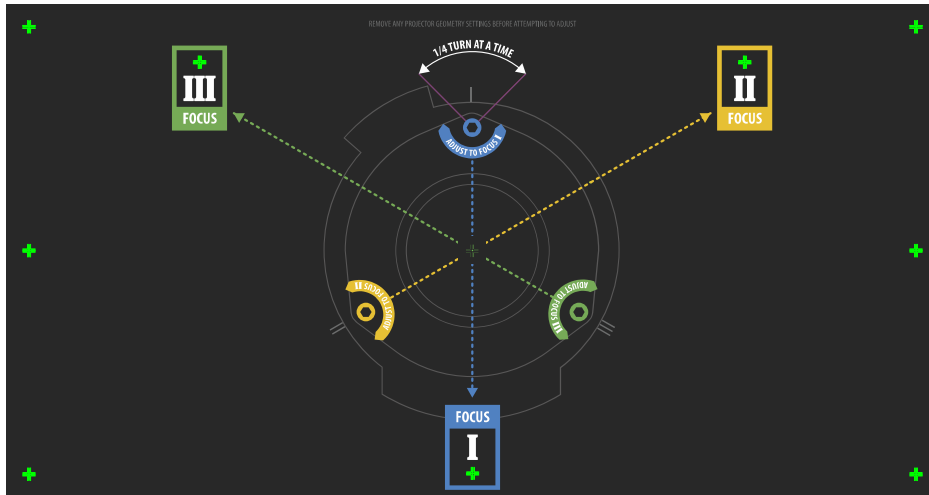

2. Focus the image on cross-hair image **I**.
3. Evaluate the focus on cross-hair image **II** and **III**.
  - If all three images are in focus, no further action is required.
  - If boresight is required, continue to step 4.

The adjustment screws (A) on the lens mount affects the corresponding cross-hairs on the test pattern.

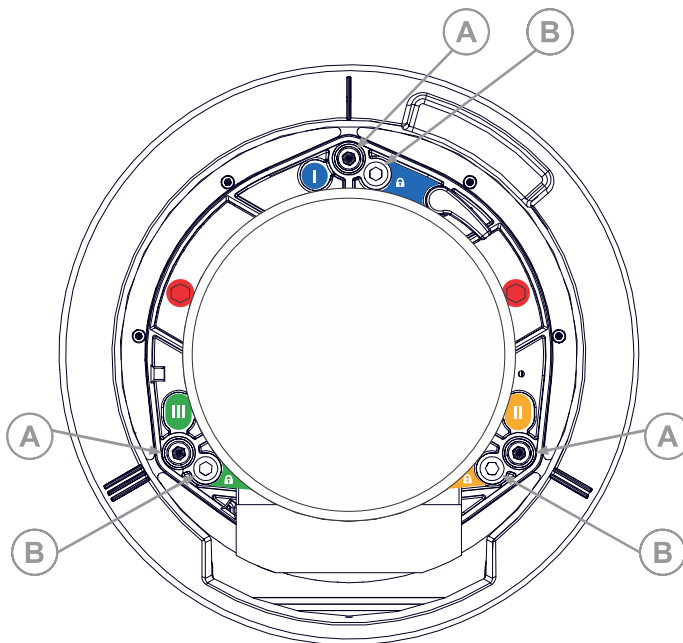

4. To loosen the three setscrews (B) on the lens mount, use a 5 mm hex driver. The setscrews must be backed out several turns to avoid contact with the inner lens mount plate.
5. To fine tune the focus of cross-hair pattern **I**, adjust the appropriate adjustment screw (A) until the cross-hair image is in focus with minimal flare.

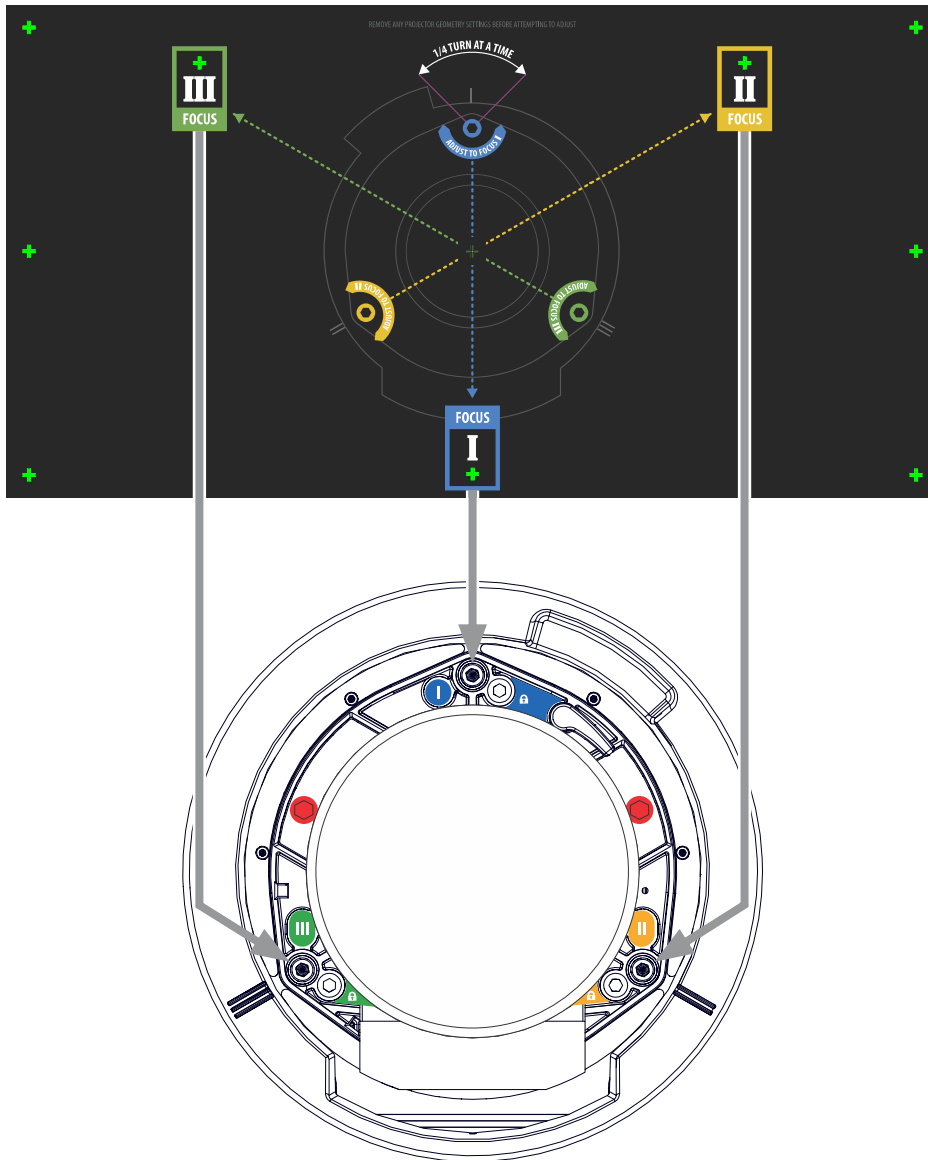

6. To fine tune cross-hair pattern **II**, adjust the appropriate adjustment screw until the cross-hair image is in focus with minimal flare.
7. To fine tune cross-hair pattern **III**, adjust the appropriate adjustment screw until the cross-hair image is in focus with minimal flare.
8. Repeat step 5 to 7 as required until all three cross-hair patterns are in equal sharp focus.
  - If the boresight is acceptable, proceed with step 11.
  - If the boresight does not appear to be converging to an acceptable level of image quality, or if the lens does not focus over the correct range of throw distances, proceed with step 9.
9. To approximately recover the original factory boresight, position the three setscrews flush with the front face of the lens mount plate and in contact with the inner lens mount plate. This may require adjusting both setscrews and adjustment screws.

10. If further action is required, repeat steps 2 to 9.
11. Lock the setscrews, and re-check the boresight quality.  
Tighten the setscrews to 2.1 Nm (18 in-lb) to make sure they do not shift.

## Optimizing the Integrator Focus and Zoom

Extreme misalignment of projection optics can cause permanent damage to critical optical components. Only Christie qualified technicians can perform internal optical adjustments.

1. From the Test Pattern menu, select the **Integrator Rod** test pattern.  
The Integrator Rod test pattern includes guided information for integrator zoom and focus adjustments.

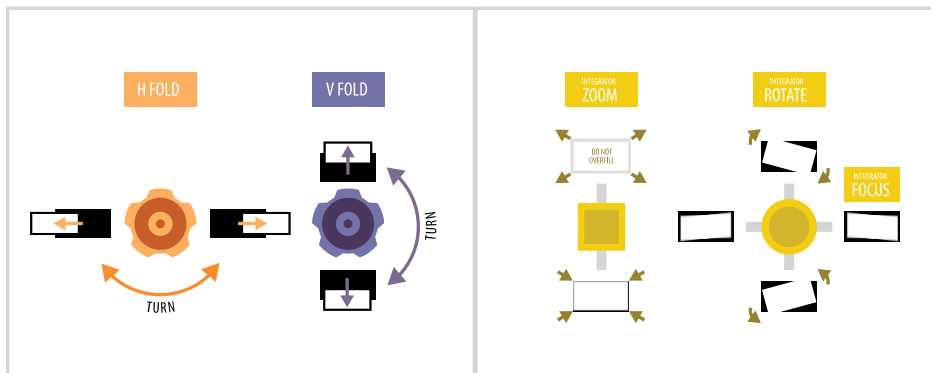

2. Set the projector brightness level to approximately 50% to 60%.
3. Retrieve the 3 mm hex driver located inside the toolbox.
4. To open the Service door on the side of the projector, loosen the two screws.
5. Loosen the Rotate and Focus lockscrew located next to the adjustment slider.

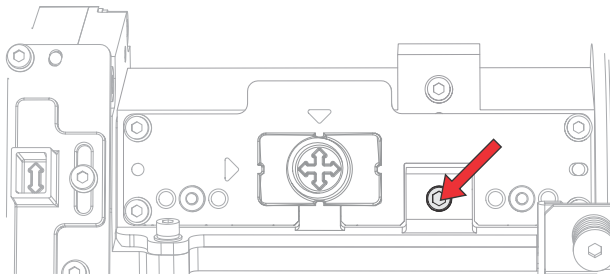

6. Loosen the integrator magnification Zoom lockscrew located next to the adjustment slider.

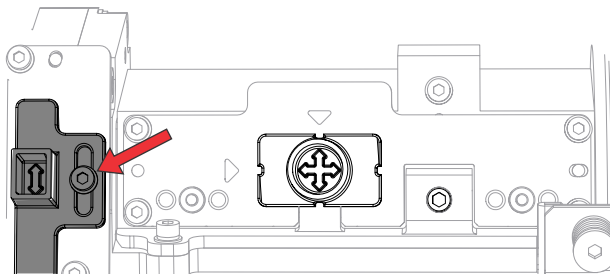

7. Move both adjustments to the nominal position before optimizing.

- To focus the integrator rod, adjust the slider vertically to rotate the image temporarily exposing the top and bottom edges.

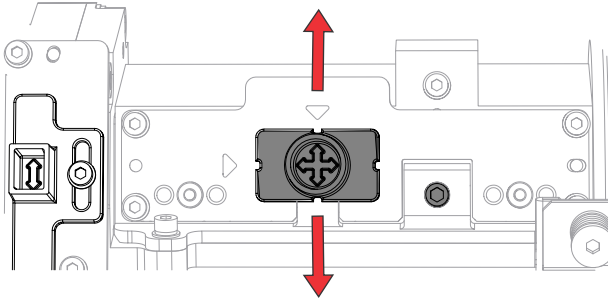

- Adjust the slider horizontally to sharpen the top and bottom edges.

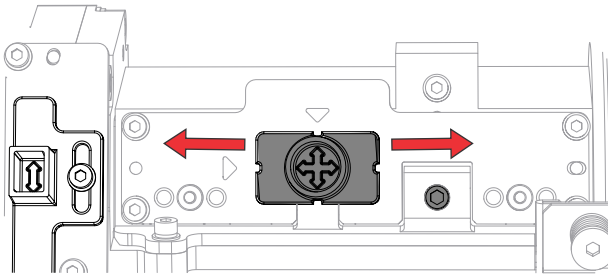

- To rotate the focused image back to fill the shadows, adjust the slider vertically.
- To optimize the digital micromirror device (DMD) brightness, adjust the integrator magnification lens using the Zoom slider.

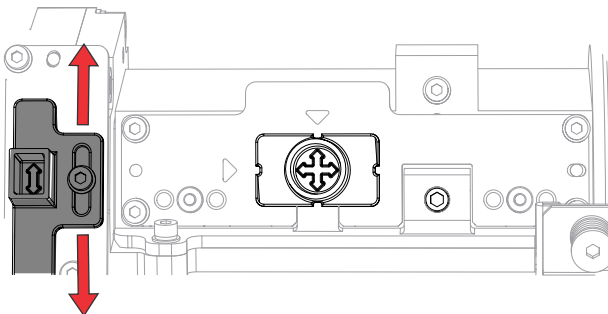

- Adjust the Zoom slider vertically until shadows are not visible on the projected image.
- Check the image quality.  
If shadows still appear in the projected image after adjusting the integrator zoom, repeat steps 6 to 11.
- Tighten the Zoom lockscrew.
- Tighten the Rotate and Focus lockscrew.

## Adjusting the fold mirror

Fold mirror adjustment must be completed by trained personnel.



**Notice.** If not avoided, the following could result in property damage.

- Misalignment of the fold mirror may cause permanent damage to the product.



1. Set the projector to minimum power.
2. From the Test Pattern menu, select the **Integrator Rod** test pattern.
3. Open the Service door on the side of the projector.
4. Unlock the fold mirror screws to unlock the adjustment knobs.

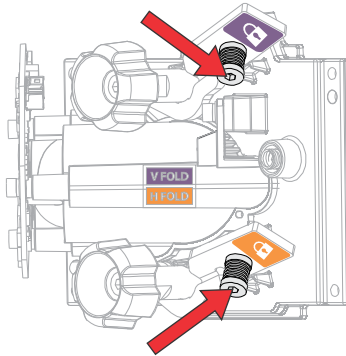

5. To make horizontal adjustments, use the orange knob labeled Horizontal.
6. To make vertical adjustments, use the purple knob labeled Vertical.
7. To continue to refine the fold mirror adjustment, repeat the horizontal and vertical adjustments.
8. Lock the fold mirror screw to lock the adjustment knobs.
9. Once satisfied with the alignment, increase the projector power.

## Adjusting digital micromirror device (DMD) convergence

A convergence problem occurs when one or more projected colors (red, green, and blue) appears misaligned when examined with a convergence test pattern.

The three colors should overlap to form pure white lines throughout the image and one or more poorly converged individual colors may appear adjacent to some or all of the lines.

When adjusting the convergence, you are adjusting blue and green to red.

1. From the Test Pattern menu, select the **Convergence** test pattern.

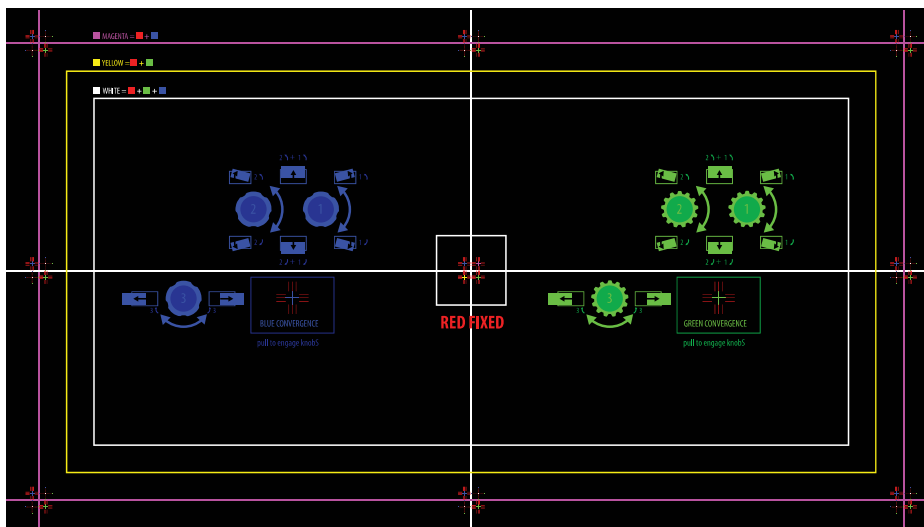

2. Open the Service door on the side of the projector.
3. To adjust the convergence knobs, use the 3 mm tool included with the projector.  
If adjusting by hand without using the tool, pull out the convergence adjustment knobs to engage them.

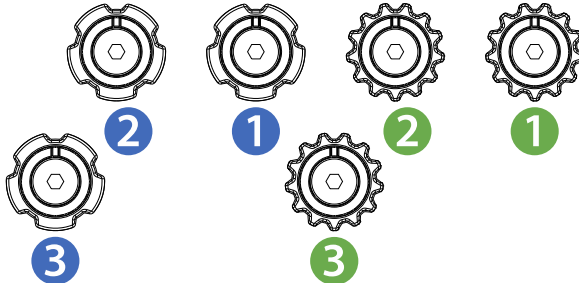

4. Use the **Convergence** test pattern to assist with adjusting the horizontal and vertical lines. Vertical convergence and rotation is done by adjusting two knobs. Christie recommends rotating a single knob a maximum of a quarter rotation before adjusting the second knob a quarter rotation. For example, if using one hand, turn the left knob a quarter rotation and then the right knob a quarter rotation, and so on. Adjusting a single knob for vertical or rotational adjustment to an extreme before adjusting the second knob may result in the convergence mechanism binding.
5. When complete, push in all the convergence adjustment knobs to disengage the knobs.

## Configuring Crimson Series to work with Christie Link

Configure Crimson Series to work with Christie Link, which provides a fully integrated fiber solution for long range video transport.

1. Turn on Crimson Series.
2. Verify the HBMIC has been installed in slot 0.
3. To enable the Christie Link option for slot 1, select **MENU > Configuration > Input Settings > Enable Christie Link (Slot 1)**.
4. To enable the Christie Link option for slot 2, select **MENU > Configuration > Input Settings > Enable Christie Link (Slot 2)**.
5. Select **Enter**.
6. Select the QSFP+ option as the input setting.
  - a) From the side panel home page, select **Input**.
  - b) On the Input selection page, select the appropriate input marked **Christie Link**.  
More than one input source may be listed as **Christie Link**, depending on how many signals are being sent from Christie Link. For example, 1-1, 2-1, and so on, where the first number in the sequence is the slot number (slot 1 or slot 2).

### Related information

*Turning on the projector* (on page 25)

## Disposing of the product packaging

Once the product has been installed and set up, Christie recommends reusing or recycling the product packaging according to your local regulations.

# Connecting devices and establishing communication

Learn how to connect external devices to the projector.

Communication and input ports are located on the projector side input panel (operator side). The image below shows an example of the video option card slot numbers and the IMXB panel; your panel may look different.

Video sources can be connected to either the ports on the video option cards or the HDBaseT port on the IMXB.

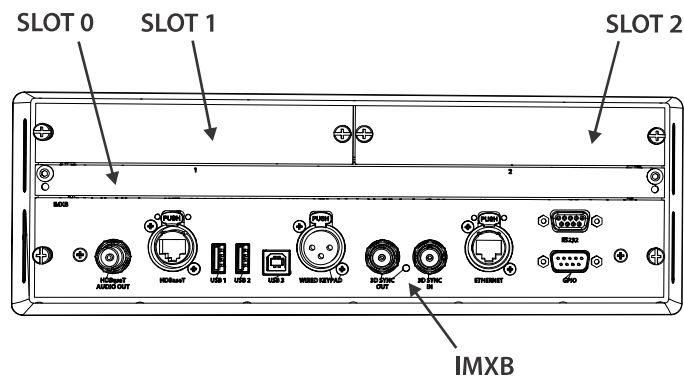

## IMXB ports

The IMXB has a variety of ports that can be used for control, 3D sync, upgrading, retrieving interrogators, and connecting audio.

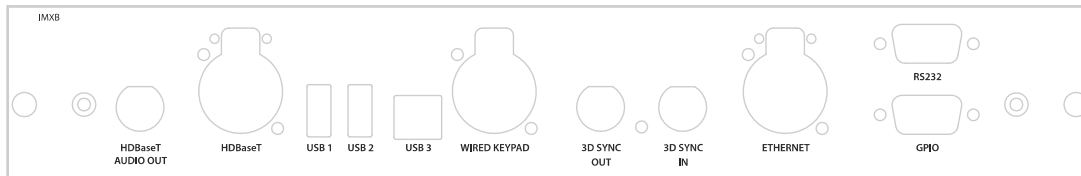

Port	Description
Audio Out	Not supported.
HDBaseT	Accepts video signals, Ethernet, and IR.

Port	Description
USB 1/USB 2	Connects a USB flash drive that has been formatted with a FAT32 file system. Can be used for upgrades, backups, restores, and interrogators.
USB 3	For manufacturing use only.
Wired Keypad	Physically connects a remote control to the projector.
3D Sync In/3D Sync Out	Supported for 3D-enabled projectors.
Ethernet	Connects to the web user interface and can send Christie serial commands.
RS232	Sends Christie serial commands using a standard RS232 serial cable.
GPIO	Provides a method for controlling the projector using electrical signals.

## Connecting a video source using 3G input card

The 3G input card (3GIC) accepts digital video data from HD and 3G-SDI (Serial Digital Interface) sources.

Part number: 108-313101-02+

Enables connection of one SDI cable to the 1-IN input of a 3GIC card (in any slot). In this configuration the SDI input supplies the entire video raster.

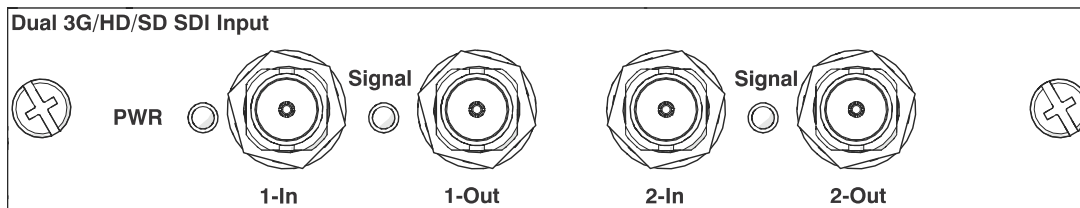

This card may or may not be included with your model. Standard inputs are subject to change. Refer to the *Crimson and Mirage Specifications Guide (P/N: 020-102724-XX)* for more details.

## Connecting a video source using DVI

The Dual Link DVI input card (DDIC) accepts digital video source from DVI sources. It does not support incoming analog signals.

Part number: 108-312101-XX

Enables connection of one DVI cable to the DVI input of a DDIC card (in any slot). In this configuration, the DVI input supplies the entire video raster.

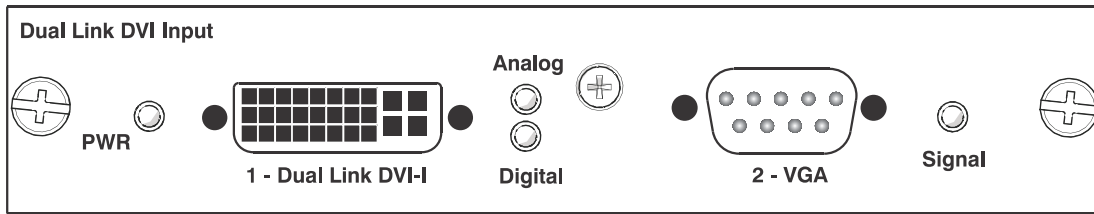

This card may or may not be included with your model. Standard inputs are subject to change. Refer to the *Crimson and Mirage Specifications Guide (P/N: 020-102724-XX)* for more details.

## Connecting a video source using DisplayPort

The Twin DisplayPort input card (TDPIC) accepts digital video data from the DisplayPort sources.

Part number: 108-451101-XX (TDPIC)

Enables connection of one DisplayPort cable to a TDPIC card. In this configuration the DisplayPort input supplies the entire video raster.

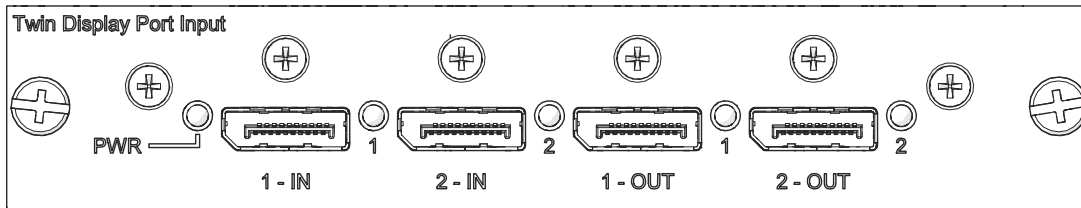

This card may or may not be included with your model. Standard inputs are subject to change. Refer to the *Crimson and Mirage Specifications Guide (P/N: 020-102724-XX)* for more details.

## Connecting a video source using HDMI

The Twin HDMI input card (THIC) accepts digital video data from HDMI sources.

Part number: 108-311101-XX

Enables connection of one HDMI cable to the 1-IN input of a THIC card (in any slot). In this configuration, the HDMI input supplies the entire video raster.

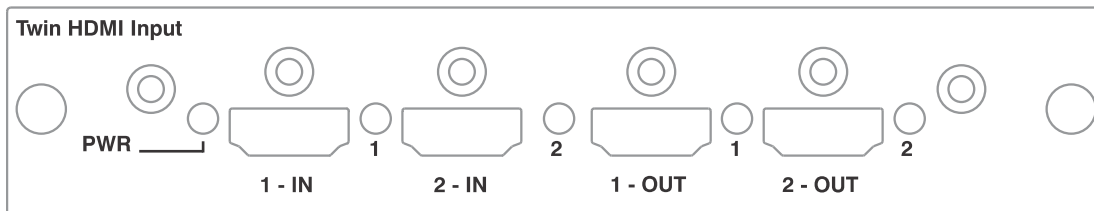

This card may or may not be included with your model. Standard inputs are subject to change. Refer to the *Crimson and Mirage Specifications Guide (P/N: 020-102724-XX)* for more details.

## Connecting a video source using HBMIC

The high bandwidth multi-input card (HBMIC) accepts digital video data from QSFP+, DisplayPort, HDMI, and 12G, 6G, 3G, and HD SDI sources.

Part number: 144-116109-XX

Enables connection of any one of the input standards, processes it, and routes it to the backplane interface. The module allows for concurrent processing of HDMI 2.0, DisplayPort 1.2, and SDI inputs to enable preview capability and fast syncing/switching between inputs. It can also be switched to Christie Link mode allowing interfacing with the Christie Link transmitter.



Crimson Series resolutions are limited to HD and WU.

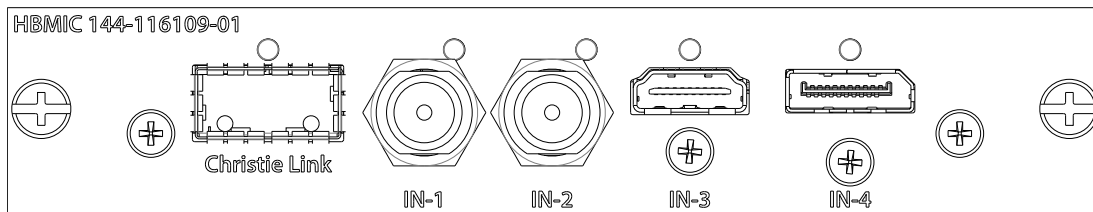

## Connecting a video source using TSIC

The Terra SDVoE (TSIC) input card accepts digital video data from a Christie Terra Transmitter.

Part number: 144-132107-XX

Enables a connection from an SDVOE source (such as the Christie Terra Transmitter) and routes it to the backplane interface. Refer to the signal chart for more information about what resolution, frame rates, and formats are supported based on the projector the card is installed in.

Input configuration	Description	Requirements
One-Port	Enables a connection from an SDVOE source (such as the Christie Terra Transmitter) and routes it to the backplane interface. Refer to the signal chart for more information about what resolution, frame rates, and formats are supported based on the projector the card is installed in.	1 TSIC card

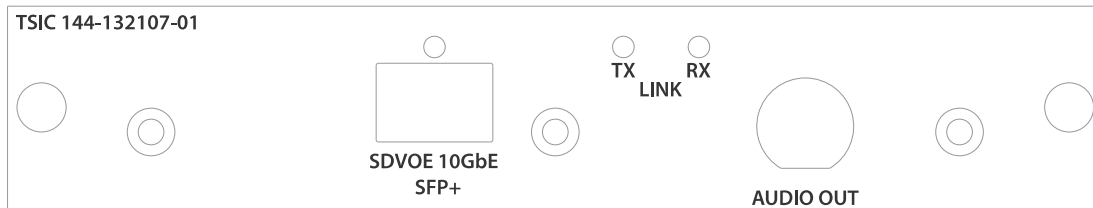

This card may or may not be included with your model. Standard inputs are subject to change. Refer to the *Crimson and Mirage Specifications Guide (P/N: 020-102724-XX)* for more details.

## Connecting a video source using HDBaseT

The HDBaseT port on the IMXB accepts digital video data from HDBaseT sources.

Enables connection of one Ethernet cable to the HDBaseT port on the IMXB. The HDBaseT input supplies the entire video raster.

This card may or may not be included with your model. Standard inputs are subject to change. Refer to the *Crimson and Mirage Specifications Guide (P/N: 020-102724-XX)* for more details.

## Selecting a video source

After connecting a video source to the projector and making sure your port configuration is correct, you must select it.

1. From the display panel, select **INPUT**.
2. Navigate the list of input selections until you find a selection that best matches your configuration.

The range of available input selections depends on the projector model and/or input/output combinations. When the Default configuration is selected, the following inputs are supported for each configuration:

- One-port—HDMI, SDI, DisplayPort, Christie Link, HDBaseT
- Two-port—DisplayPort, Christie Link
- Four-port quadrants—SDI
- One-port dual-input 3D (3D license-specific)—HDMI, SDI, DisplayPort, Christie Link

When SDVoE is selected, the HDMI, SDVoE, Christie Link, and HDBaseT inputs are supported for the one-port configuration.

3. To select the input, select **Enter**.

## Connecting to a computer or server

Communicate with a remote computer, server, or an existing network using a RJ-45 cable.

The RS232 port located on the IMXB faceplate uses the Christie proprietary protocol and is intended for Christie accessories or automation controllers only.

For more information, on the serial commands, see the *Crimson and Mirage Serial Commands Guide (P/N: 020-102660-XX)*.

1. Use an RJ-45 cable to connect the Ethernet hub or switch to the Ethernet port, located on the projector IMXB faceplate.
2. When using the Christie serial protocol over Ethernet, connect to port 3002.
3. For applications or equipment using serial communications, use the Christie proprietary serial protocol to communicate with the RS232 port on the IMXB faceplate.



## Configuring the RS232 port

Configure the RS232 port to send Christie serial commands using a standard RS232 serial cable.

For more information, on the serial commands, see the *Crimson and Mirage Serial Commands Guide* (P/N: 020-102660-XX) .

1. Select **Menu > Communications > Projector Communication**.
2. Use the down arrow to select **Baud Rate**.
3. Select the appropriate baud rate and select **Enter**.
4. Use the down arrow to select **Network Routing**.
5. Select the type network routing appropriate for your projector and select **Enter**.

## Setting up the Ethernet

Ethernet is set up to obtain an IP address automatically if a DHCP server is on the network, modify IP settings, or manually enter an address.

Christie recommends using the Ethernet port on the IMXB as the HDBaseT port is limited to 100 Mb/s.



You cannot change the IP settings using the web interface.

1. From the display panel, use the arrow keys to select **IP Settings**.
2. To set the type of network, select **DHCP** or **Static**.
3. If you selected Static, manually enter the network information for the **IP Address**, **Subnet**, and **Gateway**.
4. Select **Apply** and select **Enter**.
5. Select **MENU > Communications > Network Settings**.
6. Select **Device name**.
7. Use the up and down keys to enter the name of the projector.
8. Select **Enter**.

# 3D setup for Mirage projectors

The projector is capable of displaying stereoscopic 3D video sources, relying on additional hardware (stereo emitters and glasses) to complete the display system.

Images generated from a stereo 3D video source consist of a series of images (frames) that alternate quickly between two slightly different viewpoints, corresponding to our left and right eyes. When these frames are displayed fast enough and viewed with special glasses synchronized to the left/right (L/R) changes, the resulting image appears with the same depth and perspective sense in the real world.



The type of 3D glasses must be active stereo.

## 3D requirements

Stereo 3D applications require a stereo 3D-capable source, special hardware and software setups, and the projector's 3D Settings menu option to control the projector's processing, synchronization, and displaying of the stereoscopic 3D source material.

## Hardware requirements

Understand the hardware requirements for stereo 3D applications.

- Christie Digital Systems Mirage HD25 and Mirage WU25 Series projector
- 3D stereo sync cable for direct-input 3D (and frame doubled)
- A source, usually a computer with a 3D graphics card(s)
- Emitter for controlling active shutter glasses

## Software and content requirements

Understand the software and content requirements for stereo 3D applications.

- Any 3D computer software that supports 3D stereo on a supported computer(s) with associated graphic cards (suggested cards include ATI or NVIDIA)
- A video stream from a video source prepared to be sequential content (for direct-input 3D) or two video streams from a video source that has been prepared to be supplied left eye and right eye concurrently and frame locked (dual-input 3D)

## Active stereo 3D configuration

Use the following diagram to understand a typical hardware configuration for active stereo 3D systems.

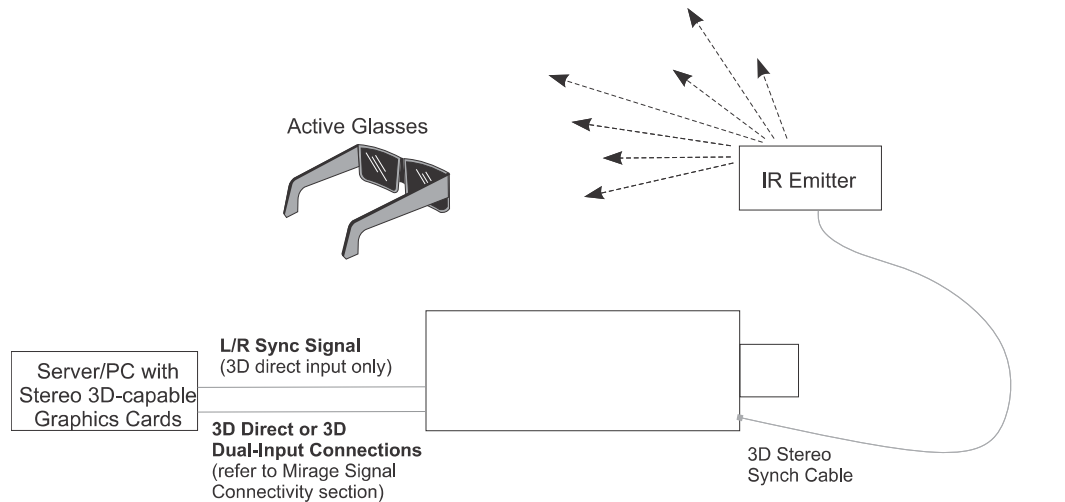

In response to the 3D Sync Out signal from the projector, the IR emitter emits an infrared signal to a receiver in the active 3D shutter glasses. This synchronizes the active glasses to alternatively open and close for the active stereo 3D applications.

## 3D system timing

The projected video must be optimized for the glasses’ shutter speed or polarization filter performance to prevent obvious “ghosting” of the video content (known as cross-talk in stereo 3D applications) or other more subtle color artifacts.

Visual performance can be optimized by adjusting the Dark Interval and the 3D Sync Delay settings. Consult the documentation for your glasses or polarization filter and keep their specifications in mind when configuring the projector for 3D operation.

## 3D input video configurations

The stereo 3D input video stream may be supplied from the video server to the projector in two configurations: direct-input 3D or dual-input 3D.

Configuration	Description
Direct-input 3D	<p>In this configuration a single video stream is provided by the video server, with the left eye and right eye frames supplied as alternate frames within the video stream. A 3D input sync may be used to identify the left eye frames.</p> <p>The direct-input 3D video stream may be supplied by either a Four-Port input video configuration (such as four cables each supplying one quadrant of the image) or an One-Port input video configuration (such as one cable supplying the entire frame).</p>

Configuration	Description
Dual-input 3D	<p>In this configuration two video streams are provided by the video server, with the left eye supplied by one stream and the right eye supplied by the other. The video streams are frame locked and supplied concurrently.</p> <p>The dual-input 3D video streams may be supplied by either two Four-Port input video configurations (such as four cables each supplying one quadrant of the image for each eye, with a total of eight cables) or two One-Port input video configurations (such as one cable supplying the entire frame for each eye, with a total of two cables).</p>

## Setting up a single projector to display 3D content

The projector must be installed correctly to display 2D content (optically aligned, focused, and so on) before completing the following steps to display the 3D content.

1. *Enable 3D mode* (on page 44).
2. *Confirm the emitter setup* (on page 44).
3. *Configure the projector for the 3D source* (on page 45).

### Enabling 3D mode

Select the mode for your 3D operation.

1. To enable 3D mode, select **MENU > Image Settings > 3D Settings > 3D Mode**.
2. Select the appropriate 3D mode:
  - Off—Disable the 3D operation.
  - Auto Detect—Automatically determine which 3D mode to use based on auxiliary video data, for example, HDMI info frame.
  - Multi-Flash 3D—Display content multiple times to provide a 3D image.

### Confirming the emitter setup

Define whether the 3D Sync is output and control how it is processed.

1. To set the 3D output to emitter, select **MENU > Image Settings > 3D Settings > 3D Sync Output**.
2. Select **To Emitter**.
3. Select **Enter**.
4. To enable the 3D test pattern, select **3D Test Pattern**.
5. Select **Enter**.
6. To configure the dark interval so the amount of dark time aligns with the amount of time required for the glasses to switch, select **Dark Interval**.
7. Adjust the slider or enter the dark interval value as required.
8. To confirm your selection, select **Enter**.

9. View the displayed test pattern. If you can see both Ls and Rs with both eyes, increase the dark interval until the Ls are only visible to the left eye and the Rs are only visible to the right eye.
10. Optionally, to adjust the 3D Sync delay, select **3D Sync Delay**.  
This adjusts the timing of the sync pulse in relation to the dark time transition on the DMDs. Use the default value of 0 as a starting point.
11. Adjust the slider or enter the delay value.
12. To confirm your selection, select **Enter**.

## Configuring the projector for the 3D source

Configure the projector for the 3D source.

1. Select the appropriate port configuration and then set the *inputs for your video source* (on page 40).
2. To select the correct EDID timing, select **MENU > Configuration > Input Settings > EDID Timing**.
3. Select the required EDID timing and select **Enter**.
4. Connect all the required cables between the 3D source and the projector.
5. Configure your 3D source.

## Connecting devices to the 3D sync ports

The 3D Sync Input and Output ports located on the IMXB faceplate provide a convenient method for interfacing the projector to the 3D stereo projection system.

Connect the 3D Sync Input to the video source for synchronization of the left eye/right eye frames of Direct input 3D or for frame doubled content.

The 3D Sync Input is not required for Dual-Input 3D. The 3D Sync Output is available for control of an IR Emitter for active glasses or a polarization device for passive glasses.

# Signal connectivity specifications for Mirage HD25 and Mirage WU25

Identify the signal connectivity specifications for Mirage HD25 and Mirage WU25.

The list of formats listed below are not exhaustive and other formats may be supported. For more information, contact Christie Technical Support.

For a list of supported Christie Link video formats, see the *Christie Link User Manual (P/N: 020-102234-XX)*.

## HBMIC video formats for Mirage projectors

Identify the video formats for the HBMIC card.

### DisplayPort 1.2

This interface supports HDCP 1.x.

	Format	Hres	Vres	Frame rate (Hz)	Sampling	Bit-depth
HD	1280x720	1280	720	24, 25, 30, 50, 60, 120	RGB/4:4:4	8/10/12bpc
	1920x1080	1920	1080	24, 25, 30, 50, 60, 120	RGB/4:4:4	8/10/12bpc
	1920x1200	1920	1200	24, 25, 30, 50, 60, 120	RGB/4:4:4	8/10/12bpc
	2048x1080	2048	1080	24, 25, 30, 50, 60, 120	RGB/4:4:4	8/10/12bpc
4K	3840x2160	3840	2160	24, 25, 30, 50, 60	RGB/4:4:4	8/10bpc
	4096x2160	4096	2160	24, 25, 30, 50, 60	RGB/4:4:4	8/10bpc

### HDMI 2.0

This interface supports HDCP 1.x and 2.2.

	Format	Hres	Vres	Frame rate (Hz)	Sampling	Bit-depth	Notes
HD	1280x720	1280	720	24, 25, 30, 50, 60, 120	RGB/4:4:4/4:2:2	8/10/12bpc	—

	Format	Hres	Vres	Frame rate (Hz)	Sampling	Bit-depth	Notes
	1920x1080i	1920	1080	50, 60	RGB/4:4:4/4:2:2	8/10/12bpc	—
	1920x1080	1920	1080	24, 25, 30, 50, 60, 120	RGB/4:4:4/4:2:2	8/10/12bpc	—
	1920x1200	1920	1200	24, 25, 30, 50, 60, 120	RGB/4:4:4/4:2:2	8/10/12bpc	—
	2048x1080	2048	1080	24, 25, 30, 50, 60, 120	RGB/4:4:4/4:2:2	8/10/12bpc	—
3D	1280x720	1280	720	60	RGB/4:4:4/4:2:2	8/10/12bpc	Frame-packing, top-and-bottom
	1920x1080	1920	1080	24, 25	RGB/4:4:4/4:2:2	8/10/12bpc	Frame-packing

### SDI (HD, 3G, 6G, and 12G-SDI)

A valid SMPTE-352 payload is required for this interface.



Mirage HD25 and Mirage WU25 resolutions are limited to HD and WU.

	Format	Hres	Vres	Frame rate (Hz)	Sampling	Bit-depth	Notes
HD	1280x720	1280	720	24, 25, 30, 50, 60	4:2:2	10bpc	—
	1920x1080i	1920	1080	50, 60	4:2:2	10bpc	—
	1920x1080	1920	1080	24, 25, 30	4:2:2	10bpc	—
	2048x1080	2048	1080	24, 25, 30	4:2:2	10bpc	—
3G	1280x720	1280	720	24, 25, 30, 50, 60	RGB/4:4:4	10/12bpc	Level-A only
	1920x1080i	1920	1080	50, 60	RGB/4:4:4	10/12bpc	Level-A only
	1920x1080	1920	1080	24, 25, 30	RGB/4:4:4	10/12bpc	Level-A only
	1920x1080	1920	1080	50, 60	4:2:2	10bpc	Level-A only
	2048x1080	2048	1080	24, 25, 30	RGB/4:4:4	10/12bpc	Level-A only
	2048x1080	2048	1080	50, 60	4:2:2	10bpc	Level-A only
6G	1920x1080	1920	1080	50, 60	RGB/4:4:4	10/12bpc	—
	2048x1080	2048	1080	50, 60	RGB/4:4:4	10/12bpc	—

## TSIC video formats for Mirage projectors

Identify the video formats for the Terra SDVoE (TSIC) input card.

The TSIC (HDMI 2.0) interface supports HDCP 1.x and 2.2.

	Format	Hres	Vres	Frame rate (Hz)	Sampling	Bit-depth	Notes
HD	1280x720	1280	720	24, 25, 30, 50, 60	RGB/4:4:4/4:2:2	8/10/12bpc	—
	1920x1080	1920	1080	50, 60	RGB/4:4:4/4:2:2	8/10/12bpc	—
	1920x1080	1920	1080	24, 25, 30, 50, 60	RGB/4:4:4/4:2:2	8/10/12bpc	—
	1920x1200	1920	1200	24, 25, 30, 50, 60	RGB/4:4:4/4:2:2	8/10/12bpc	—
	2048x1080	2048	1080	24, 25, 30, 50, 60	RGB/4:4:4/4:2:2	8/10/12bpc	—
3D	1280x720	1280	720	60	RGB/4:4:4/4:2:2	8/10/12bpc	Frame-packing, top-and-bottom
	1920x1080	1920	1080	24, 25	RGB/4:4:4/4:2:2	8/10/12bpc	Frame-packing

## TDPIC video formats for Mirage projectors

Identify the video formats for the TDPIC card.

The DisplayPort 1.1a interface supports HDCP 1.x.

	Format	Cables	Hres	Vres	Frame rate (Hz)	Sampling	Bit-depth
HD	1280x720	—	1280	720	24, 25, 30, 50, 60, 120	RGB/4:4:4	8/10bpc
	1920x1080	—	1920	1080	24, 25, 30, 50, 60, 120	RGB/4:4:4	8/10bpc
	1920x1200	—	1920	1200	24, 25, 30, 50, 60, 120	RGB/4:4:4	8/10bpc
	2048x1080	—	2048	1080	24, 25, 30, 50, 60, 120	RGB/4:4:4	8/10bpc

## DDIC video formats for Mirage projectors

Identify the video formats for the DDIC card. The DVI-D interface supports HDCP 1.x.

	Format	Cables	Hres	Vres	Frame rate (Hz)	Sampling	Bit-depth	Notes
HD	1280x720	—	1280	720	60	RGB/4:4:4	8bpc	Dual-link (120 Hz)
	1920x1080	—	1920	1080	24, 25, 30, 50, 60, 120	RGB/4:4:4	8bpc	Dual-link (120 Hz)
	1920x1200	—	1920	1200	24, 25, 30, 50, 60, 120	RGB/4:4:4	8bpc	Dual-link (120 Hz)



	Format	Cables	Hres	Vres	Frame rate (Hz)	Sampling	Bit-depth	Notes
	2048x1080	—	2048	1080	24, 25, 30, 50, 60, 120	RGB/4:4:4	8bpc	Dual-link (120 Hz)

## THIC video formats for Mirage projectors

Identify the video formats for the THIC card. The HDMI 1.3 interface supports HDMI 1.4a 3D formats and HDCP 1.x.

	Format	Cables	Hres	Vres	Frame rate (Hz)	Sampling	Bit-depth	Notes
HD	1280x720	—	1280	720	24, 25, 30, 50, 60, 120	RGB/4:4:4/4:2:2	8/10/12bpc	—
	1920x1080i	—	1920	1080	50, 60	RGB/4:4:4/4:2:2	8/10/12bpc	—
	1920x1080	—	1920	1080	24, 25, 30, 50, 60	RGB/4:4:4/4:2:2	8/10/12bpc	—
	1920x1200	—	1920	1200	24, 25, 30, 50, 60	RGB/4:4:4/4:2:2	8/10/12bpc	—
	2048x1080	—	2048	1080	24, 25, 30, 50, 60	RGB/4:4:4/4:2:2	8/10/12bpc	—
3D	1280x720	—	1280	720	60	RGB/4:4:4/4:2:2	8/10/12bpc	Frame-packing, top-and-bottom
	1920x1080	—	1920	1080	24, 25	RGB/4:4:4/4:2:2	8/10/12bpc	Frame-packing

## 3GIC video formats for Mirage projectors

Identify the video formats for the 3GIC card for HD and 3G-SDI.

	Format	Cables	Hres	Vres	Frame rate (Hz)	Sampling	Bit-depth	Notes
HD	1280x720	—	1280	720	24, 25, 30, 50, 60	4:2:2	10bpc	—
	1920x1080i	—	1920	1080	50, 60	4:2:2	10bpc	—
	1920x1080	—	1920	1080	24, 25, 30	4:2:2	10bpc	—
	2048x1080	—	2048	1080	24, 25, 30	4:2:2	10bpc	—
3G	1280x720	—	1280	720	24, 25, 30, 50, 60	RGB/4:4:4	10/12bpc	Level-A recommended
	1920x1080i	—	1920	1080	50, 60	RGB/4:4:4	10/12bpc	Level-A recommended
	1920x1080	—	1920	1080	24, 25, 30	RGB/4:4:4	10/12bpc	Level-A recommended
	1920x1080	—	1920	1080	50, 60	4:2:2	10bpc	Level-A recommended

	Format	Cables	Hres	Vres	Frame rate (Hz)	Sampling	Bit-depth	Notes
	2048x1080	—	2048	1080	24, 25, 30	RGB/4:4:4	10/12bpc	Level-A recommended
	2048x1080	—	2048	1080	50, 60	4:2:2	10bpc	Level-A recommended

## HDBase-T video formats for Mirage projectors

Identify the video formats for the HDBase-T card. The HDMI 1.4 interface supports HDCP 1.x.

	Format	Hres	Vres	Frame rate (Hz)	Sampling	Bit-depth	Notes
HD	1280x720	1280	720	24, 25, 30, 50, 60, 120	RGB/4:4:4/4:2:2	8/10/12bpc	—
	1920x1080i	1920	1080	50, 60	RGB/4:4:4/4:2:2	8/10/12bpc	—
	1920x1080	1920	1080	24, 25, 30, 50, 60, 120	RGB/4:4:4/4:2:2	8/10/12bpc	—
	1920x1200	1920	1200	24, 25, 30, 50, 60, 120	RGB/4:4:4/4:2:2	8/10/12bpc	—
	2048x1080	2048	1080	24, 25, 30, 50, 60, 120	RGB/4:4:4/4:2:2	8/10/12bpc	—
3D	1280x720	1280	720	60	RGB/4:4:4/4:2:2	8/10/12bpc	Frame-packing, top-and-bottom
	1920x1080	1920	1080	24, 25	RGB/4:4:4/4:2:2	8/10/12bpc	Frame-packing

## Dual-input 3D for Mirage projectors

Identify the video formats for the Dual-input 3D.

One set of cables is required for left-eye and another set is required for right-eye. The output rate depends on the input rate (per eye) as follows:

- 24 Hz signals are triple-flashed resulting in an output rate of 144 Hz.
- 25 Hz signals are triple-flashed resulting in an output rate of 150 Hz.
- 30 Hz signals are double-flashed resulting in an output rate of 120 Hz.
- 60 Hz signals are single-flashed resulting in an output rate of native 120 Hz.

### HBMIC

A valid SMPTE-352 payload is required for the SDI interface (HD, 3G, and 6G).

	Format	Cables	Hres	Vres	Frame rate (Hz)	Sampling	Bit-depth
HD	1280x720	2x	1280	720	24, 25, 30, 60	4:2:2	10bpc

	<b>Format</b>	<b>Cables</b>	<b>Hres</b>	<b>Vres</b>	<b>Frame rate (Hz)</b>	<b>Sampling</b>	<b>Bit-depth</b>
3G	1920x1080	2x	1920	1080	24, 25, 30	4:2:2	10bpc
	2048x1080	2x	2048	1080	24, 25, 30	4:2:2	10bpc
	1280x720	2x	1280	720	24, 25, 30, 60	RGB/4:4:4	10/12bpc
	1920x1080	2x	1920	1080	24, 25, 30	RGB/4:4:4	10/12bpc
	1920x1080	2x	1920	1080	60	4:2:2	10bpc
	2048x1080	2x	2048	1080	24, 25, 30	RGB/4:4:4	10/12bpc
6G	2048x1080	2x	2048	1080	60	4:2:2	10bpc
	1920x1080	2x	1920	1080	60	RGB/4:4:4	10/12bpc
	2048x1080	2x	2048	1080	60	RGB/4:4:4	10/12bpc

**TDPIC**

The DisplayPort 1.1a interface supports HDCP 1.x.

	<b>Format</b>	<b>Cables</b>	<b>Hres</b>	<b>Vres</b>	<b>Frame rate (Hz)</b>	<b>Sampling</b>	<b>Bit-depth</b>
HD	1280x720	2x	1280	720	24, 25, 30, 60	RGB/4:4:4	8/10bpc
	1920x1080	2x	1920	1080	24, 25, 30, 60	RGB/4:4:4	8/10bpc
	1920x1200	2x	1920	1200	24, 25, 30, 60	RGB/4:4:4	8/10bpc
	2048x1080	2x	2048	1080	24, 25, 30, 60	RGB/4:4:4	8/10bpc

**DDIC**

The DVI-D interface supports HDCP 1.x.

	<b>Format</b>	<b>Cables</b>	<b>Hres</b>	<b>Vres</b>	<b>Frame rate (Hz)</b>	<b>Sampling</b>	<b>Bit-depth</b>
HD	1280x720	2x	1280	720	60	RGB/4:4:4	8bpc
	1920x1080	2x	1920	1080	24, 25, 30, 60	RGB/4:4:4	8bpc
	1920x1200	2x	1920	1200	24, 25, 30, 60	RGB/4:4:4	8bpc
	2048x1080	2x	2048	1080	24, 25, 30, 60	RGB/4:4:4	8bpc

**THIC**

The HDMI 1.4 interface supports HDCP 1.x.

	<b>Format</b>	<b>Cables</b>	<b>Hres</b>	<b>Vres</b>	<b>Frame rate (Hz)</b>	<b>Sampling</b>	<b>Bit-depth</b>
HD	1280x720	2x	1280	720	24, 25, 30, 60	RGB/4:4:4/4:2:2	8/10/12bpc
	1920x1080	2x	1920	1080	24, 25, 30, 60	RGB/4:4:4/4:2:2	8/10/12bpc
	1920x1200	2x	1920	1200	24, 25, 30, 60	RGB/4:4:4/4:2:2	8/10/12bpc
	2048x1080	2x	2048	1080	24, 25, 30, 60	RGB/4:4:4/4:2:2	8/10/12bpc

**3GIC (HD and 3G-SDI)**

	Format	Cables	Hres	Vres	Frame rate (Hz)	Sampling	Bit-depth	Notes
HD	1280x720	2x	1280	720	24, 25, 30, 60	4:2:2	10bpc	—
	1920x1080	2x	1920	1080	24, 25, 30	4:2:2	10bpc	—
	2048x1080	2x	2048	1080	24, 25, 30	4:2:2	10bpc	—
3G	1280x720	2x	1280	720	24, 25, 30, 60	RGB/4:4:4	10/12bpc	Level-A recommended
	1920x1080	2x	1920	1080	24, 25, 30	RGB/4:4:4	10/12bpc	Level-A recommended
	1920x1080	2x	1920	1080	60	4:2:2	10bpc	Level-A recommended
	2048x1080	2x	2048	1080	24, 25, 30	RGB/4:4:4	10/12bpc	Level-A recommended
	2048x1080	2x	2048	1080	60	4:2:2	10bpc	Level-A recommended

# Signal connectivity specifications for Crimson HD and WU

Identify the signal connectivity specifications for Crimson HD and WU.

The list of formats listed below are not exhaustive and other formats may be supported. For more information, contact Christie Technical Support.

For a list of supported Christie Link video formats, see the *Christie Link User Manual (P/N: 020-102234-XX)*.

## HBMIC video formats

Identify the video formats for the HBMIC card.

### DisplayPort 1.2

This interface supports HDCP 1.x.

	Format	Hres	Vres	Frame rate (Hz)	Sampling	Bit-depth
HD	1280x720	1280	720	24, 25, 30, 50, 60	RGB/4:4:4	8/10/12bpc
	1920x1080	1920	1080	24, 25, 30, 50, 60	RGB/4:4:4	8/10/12bpc
	1920x1200	1920	1200	24, 25, 30, 50, 60	RGB/4:4:4	8/10/12bpc
	2048x1080	2048	1080	24, 25, 30, 50, 60	RGB/4:4:4	8/10/12bpc

### HDMI 2.0

This interface supports HDCP 1.x and 2.2.

	Format	Hres	Vres	Frame rate (Hz)	Sampling	Bit-depth
HD	1280x720	1280	720	24, 25, 30, 50, 60	RGB/4:4:4/4:2:2	8/10/12bpc
	1920x1080i	1920	1080	50, 60	RGB/4:4:4/4:2:2	8/10/12bpc
	1920x1080	1920	1080	24, 25, 30, 50, 60	RGB/4:4:4/4:2:2	8/10/12bpc
	1920x1200	1920	1200	24, 25, 30, 50, 60	RGB/4:4:4/4:2:2	8/10/12bpc
	2048x1080	2048	1080	24, 25, 30, 50, 60	RGB/4:4:4/4:2:2	8/10/12bpc

### SDI (HD, 3G, 6G, and 12G-SDI)

A valid SMPTE-352 payload is required for this interface.



Crimson HD and WU resolutions are limited to HD and WU.

	Format	Hres	Vres	Frame rate (Hz)	Sampling	Bit-depth	Notes
HD	1280x720	1280	720	24, 25, 30, 50, 60	4:2:2	10bpc	—
	1920x1080i	1920	1080	50, 60	4:2:2	10bpc	—
	1920x1080	1920	1080	24, 25, 30	4:2:2	10bpc	—
	2048x1080	2048	1080	24, 25, 30	4:2:2	10bpc	—
3G	1280x720	1280	720	24, 25, 30, 50, 60	RGB/4:4:4	10/12bpc	Level-A only
	1920x1080i	1920	1080	50, 60	RGB/4:4:4	10/12bpc	Level-A only
	1920x1080	1920	1080	24, 25, 30	RGB/4:4:4	10/12bpc	Level-A only
	1920x1080	1920	1080	50, 60	4:2:2	10bpc	Level-A only
	2048x1080	2048	1080	24, 25, 30	RGB/4:4:4	10/12bpc	Level-A only
	2048x1080	2048	1080	50, 60	4:2:2	10bpc	Level-A only
6G	1920x1080	1920	1080	50, 60	RGB/4:4:4	10/12bpc	—
	2048x1080	2048	1080	50, 60	RGB/4:4:4	10/12bpc	—

## TSIC video formats

Identify the video formats for the Terra SDVoE (TSIC) input card.

The TSIC (HDMI 2.0) interface supports HDCP 1.x and 2.2.

	Format	Hres	Vres	Frame rate (Hz)	Sampling	Bit-depth
HD	1280x720	1280	720	24, 25, 30, 50, 60	RGB/4:4:4/4:2:2	8/10/12bpc
	1920x1080	1920	1080	50, 60	RGB/4:4:4/4:2:2	8/10/12bpc
	1920x1080	1920	1080	24, 25, 30, 50, 60	RGB/4:4:4/4:2:2	8/10/12bpc
	1920x1200	1920	1200	24, 25, 30, 50, 60	RGB/4:4:4/4:2:2	8/10/12bpc
	2048x1080	2048	1080	24, 25, 30, 50, 60	RGB/4:4:4/4:2:2	8/10/12bpc

## TDPIC video formats

Identify the video formats for the TDPIC card.

The DisplayPort 1.1a interface supports HDCP 1.x.

	Format	Hres	Vres	Frame rate (Hz)	Sampling	Bit-depth
HD	1280x720	1280	720	24, 25, 30, 50, 60	RGB/4:4:4	8/10bpc

	Format	Hres	Vres	Frame rate (Hz)	Sampling	Bit-depth
	1920x1080	1920	1080	24, 25, 30, 50, 60	RGB/4:4:4	8/10bpc
	1920x1200	1920	1200	24, 25, 30, 50, 60	RGB/4:4:4	8/10bpc
	2048x1080	2048	1080	24, 25, 30, 50, 60	RGB/4:4:4	8/10bpc

## DDIC video formats

Identify the video formats for the DDIC card. The DVI-D interface supports HDCP 1.x.

	Format	Hres	Vres	Frame rate (Hz)	Sampling	Bit-depth
HD	1280x720	1280	720	60	RGB/4:4:4	8bpc
	1920x1080	1920	1080	24, 25, 30, 50, 60	RGB/4:4:4	8bpc
	1920x1200	1920	1200	24, 25, 30, 50, 60	RGB/4:4:4	8bpc
	2048x1080	2048	1080	24, 25, 30, 50, 60	RGB/4:4:4	8bpc

## THIC video formats

Identify the video formats for the THIC card. The HDMI 1.3 interface supports HDCP 1.x.

	Format	Hres	Vres	Frame rate (Hz)	Sampling	Bit-depth
HD	1280x720	1280	720	24, 25, 30, 50, 60	RGB/4:4:4/4:2:2	8/10/12bpc
	1920x1080i	1920	1080	50, 60	RGB/4:4:4/4:2:2	8/10/12bpc
	1920x1080	1920	1080	24, 25, 30, 50, 60	RGB/4:4:4/4:2:2	8/10/12bpc
	1920x1200	1920	1200	24, 25, 30, 50, 60	RGB/4:4:4/4:2:2	8/10/12bpc
	2048x1080	2048	1080	24, 25, 30, 50, 60	RGB/4:4:4/4:2:2	8/10/12bpc

## HDBase-T video formats

Identify the video formats for the HDBase-T card. The HDMI 1.4 interface supports HDCP 1.x.

	Format	Hres	Vres	Frame rate (Hz)	Sampling	Bit-depth
HD	1280x720	1280	720	24, 25, 30, 50, 60	RGB/4:4:4/4:2:2	8/10/12bpc
	1920x1080i	1920	1080	50, 60	RGB/4:4:4/4:2:2	8/10/12bpc
	1920x1080	1920	1080	24, 25, 30, 50, 60	RGB/4:4:4/4:2:2	8/10/12bpc
	1920x1200	1920	1200	24, 25, 30, 50, 60	RGB/4:4:4/4:2:2	8/10/12bpc
	2048x1080	2048	1080	24, 25, 30, 50, 60	RGB/4:4:4/4:2:2	8/10/12bpc

## 3GIC video formats

Identify the video formats for the 3GIC card for HD and 3G-SDI.

	<b>Format</b>	<b>Hres</b>	<b>Vres</b>	<b>Frame rate (Hz)</b>	<b>Sampling</b>	<b>Bit-depth</b>	<b>Notes</b>
HD	1280x720	1280	720	24, 25, 30, 50, 60	4:2:2	10bpc	—
	1920x1080i	1920	1080	50, 60	4:2:2	10bpc	—
	1920x1080	1920	1080	24, 25, 30	4:2:2	10bpc	—
	2048x1080	2048	1080	24, 25, 30	4:2:2	10bpc	—
3G	1280x720	1280	720	24, 25, 30, 50, 60	RGB/4:4:4	10/12bpc	Level-A recommended
	1920x1080i	1920	1080	50, 60	RGB/4:4:4	10/12bpc	Level-A recommended
	1920x1080	1920	1080	24, 25, 30	RGB/4:4:4	10/12bpc	Level-A recommended
	1920x1080	1920	1080	50, 60	4:2:2	10bpc	Level-A recommended
	2048x1080	2048	1080	24, 25, 30	RGB/4:4:4	10/12bpc	Level-A recommended
	2048x1080	2048	1080	50, 60	4:2:2	10bpc	Level-A recommended



# Regulatory

This product conforms to the latest regulations and standards related to product safety, environmental, and electromagnetic compatibility (EMC) requirements.

## Safety

- ANSI/UL 60950-1 – Information Technology Equipment – Safety – Part 1: General Requirements
- CAN/CSA C22.2 No. 60950-1-07 – Information Technology Equipment – Safety – Part 1: General Requirements
- IEC/EN 60825-1 – Safety of Laser Products – Part 1: Equipment Classification and Requirements
- IEC 60950-1 IEC/EN 60950-1 – Information Technology Equipment – Safety – Part 1: General Requirements
- IEC/EN 62471-5 – Photobiological Safety of Lamps and Lamp Systems – Part 5: Image projectors

## Electro-magnetic compatibility

### Emissions

- CAN ICES-003 (A)/NMB-003 (A) – Information Technology Equipment (Including Digital Apparatus) – Limits and Methods of Measurement
- CISPR 32/EN 55032, Class A – Electromagnetic Compatibility of Multimedia Equipment – Emission Requirements
- FCC CFR47, Part 15, Subpart B, Class A – Unintentional Radiators
- IEC 61000-3-2/EN61000-3-2: Limits for Harmonic Current Emissions
- IEC 61000-3-3/EN61000-3-3: Limitations of Voltage Changes, Voltage Fluctuations, and Flicker

### Immunity

- CISPR 24/EN55024 EMC Requirements – Information Technology Equipment – Immunity Characteristics – Limits and Methods of Measurements
- CISPR 35/EN55035 Electromagnetic Compatibility of Multimedia Equipment - Immunity Requirements

## Environmental

- China Ministry of Information Industry (along with 7 other Government Agencies) Order No.32 (01/2016) on the control of pollution caused by electronic information products, hazardous substances concentration limits (GB/T 26572 - 2011), and the applicable product marking requirement (SJ/T 11364 - 2014).
- EU Directive (2011/65/EU) on the restriction of the uses of certain hazardous substances (RoHS) in electrical and electronic equipment and the applicable official amendment(s).
- EU Directive (2012/19/EU) on waste and electrical and electronic equipment (WEEE) and the applicable official amendment(s).
- Regulation (EC) No. 1907/2006 on the registration, evaluation, authorization and restriction of chemicals (REACH) and the applicable official amendment(s).

