

Installation and Setup Guide  
020-103943-02

# Cinema 4K-RGBH

**CHRISTIE®**

## NOTICES

### COPYRIGHT AND TRADEMARKS

Copyright © 2026 Christie Digital Systems USA Inc. All rights reserved.

All brand names and product names are trademarks, registered trademarks or trade names of their respective holders.

### GENERAL

Every effort has been made to ensure accuracy, however in some cases changes in the products or availability could occur which may not be reflected in this document. Christie reserves the right to make changes to specifications at any time without notice. Performance specifications are typical, but may vary depending on conditions beyond Christie's control such as maintenance of the product in proper working conditions. Performance specifications are based on information available at the time of printing. Christie makes no warranty of any kind with regard to this material, including, but not limited to, implied warranties of fitness for a particular purpose. Christie will not be liable for errors contained herein or for incidental or consequential damages in connection with the performance or use of this material. Our centers of excellence for manufacturing in Kitchener, Ontario, Canada and in Shenzhen, China are ISO 9001:2015 Quality Management System-certified.

Christie is committed to making our documents free from language bias; however, we are not responsible for the language used on any linked or third-party documentation.

For the most current technical documentation and office contact information, visit <https://www.christiedigital.com/>.

### Warranty

Products are warranted under Christie's standard limited warranty, the details of which are available at <https://www.christiedigital.com/help-center/warranties/> or by contacting your Christie dealer or Christie.

### REGULATORY

The product has been tested and found to comply with the limits for a Class A digital device, pursuant to Part 15 of the FCC Rules. These limits are designed to provide reasonable protection against harmful interference when the product is operated in a commercial environment. The product generates, uses, and can radiate radio frequency energy and, if not installed and used in accordance with the instruction manual, may cause harmful interference to radio communications. Operation of the product in a residential area is likely to cause harmful interference in which case the user will be required to correct the interference at the user's own expense. Changes or modifications not expressly approved by the party responsible for compliance could void the user's authority to operate the equipment.

CAN ICES-3 (A) / NMB-3 (A)

이 기기는 업무용(A급)으로 전자파적합등록을 한 기기이오니 판매자 또는 사용자는 이점을 주의하시기 바라며, 가정 외의 지역에서 사용하는 것을 목적으로 합니다.

### ENVIRONMENTAL



The product is designed and manufactured with high-quality materials and components some of which can be recycled and reused. This symbol  means electrical and electronic equipment, at their end-of-life, should be disposed of separately from regular waste. Please dispose of the product appropriately and according to local regulations. In the European Union, separate collection systems are for used electrical and electronic products.

If printing this document, consider printing only the pages you need and select the double-sided option.

Please help us to conserve the environment we live in!

### Notation

Learn the hazard and information symbols used in the product documentation.



Danger messages indicate a hazardous situation which, if not avoided, results in death or serious injury.



Warning messages indicate a hazardous situation which, if not avoided, could result in death or serious injury.



Caution messages indicate a hazardous situation which, if not avoided, could result in minor or moderate injury.



Notice messages indicate a hazardous situation which, if not avoided, may result in equipment or property damage.



Information messages provide additional information, emphasize or provide a useful tip.

# Content

<b>Important safety guidelines. . . . .</b>	<b>6</b>
Important safety guidelines. . . . .	6
General safety precautions. . . . .	6
Laser safety precautions. . . . .	7
AC power precautions. . . . .	7
Light intensity hazard distance. . . . .	8
Product labels. . . . .	14
General hazards. . . . .	14
Mandatory actions. . . . .	15
Electrical labels. . . . .	15
Additional hazard labels. . . . .	16
Laser labels. . . . .	16
<b>Introduction. . . . .</b>	<b>17</b>
Models. . . . .	17
What's new in the guide?. . . . .	17
Projector overview. . . . .	17
Key features. . . . .	18
List of included accessories. . . . .	18
Accessories. . . . .	18
Projector components. . . . .	20
Related documentation. . . . .	21
Accessing the product documentation. . . . .	21
Downloading interconnect and line drawings. . . . .	21
Downloading preventative maintenance schedules. . . . .	22
Cinema calculator tool. . . . .	22
Viewing Christie University product training videos. . . . .	22
Contact your dealer. . . . .	22
Technical support. . . . .	23
<b>Installing and setting up. . . . .</b>	<b>24</b>
Site requirements. . . . .	24
Power requirements. . . . .	25
Best practices when installing a projector. . . . .	25

Preparing the installation site. . . . .	25
Lifting and positioning the projector. . . . .	26
Mounting the projector in inverted ceiling position. . . . .	27
Mounting the projector in lens-up position. . . . .	31
Connecting to an uninterruptible power supply. . . . .	34
Installing the lens. . . . .	38
Selecting the lens type. . . . .	40
Calibrating the lens motor. . . . .	40
Removing the lens. . . . .	41
Installing the touch panel. . . . .	41
Projector power modes. . . . .	41
Using the web user interface (Web UI). . . . .	42
Turning on or off the projector. . . . .	42
Logging into the projector. . . . .	42
Turning on or off the light source. . . . .	43
Checking for the latest software version. . . . .	43
Activating marriage. . . . .	43
Disposing of the product packaging. . . . .	44
Completing the installation checklist. . . . .	44
<b>Video Input panel. . . . .</b>	<b>45</b>
HDMI video source. . . . .	46
SDI video source. . . . .	47
DisplayPort video source. . . . .	47
Integrated Media Block (IMB) video source. . . . .	47
HDMI video source connection from an Integrated Media Block (IMB). . . . .	48
SDI video source connection from an Integrated Media Block (IMB). . . . .	48
GPIO connector. . . . .	48
<b>Managing the light source. . . . .</b>	<b>51</b>
Creating a new laser file. . . . .	51
Modifying an existing laser file. . . . .	52
Copying existing laser settings to a new file. . . . .	52
Deleting a laser file. . . . .	52
LiteLOC™ sensor-to-screen calibration . . . . .	53
Running a Hawkeye calibration. . . . .	53
Adding a calibration file to the Channel Setup. . . . .	53
<b>Adjusting the image. . . . .</b>	<b>55</b>

Calibrating the Intelligent Lens System. . . . .	55
Correcting vignetting. . . . .	55
Adjusting tilt and leveling the projector. . . . .	55
Correcting keystone effect. . . . .	56
Displaying a test pattern. . . . .	57
Adjusting the integrator rod focus and fold mirror. . . . .	57
Aligning the boresight. . . . .	61
Correcting on-screen color. . . . .	64
Electronic Color Convergence (ECC). . . . .	64
Mechanically adjusting digital micromirror device (DMD) convergence. . . . .	64
Electronically adjusting convergence. . . . .	68
<b>Performing a backup. . . . .</b>	<b>70</b>
<b>Regulatory. . . . .</b>	<b>71</b>
Safety. . . . .	71
Electro-magnetic compatibility. . . . .	71
Emissions. . . . .	71
Immunity. . . . .	71
California law on security. . . . .	72
Environmental. . . . .	72

# Important safety guidelines

To prevent personal injury and to protect the device from damage, read and follow these safety precautions. This projector is intended for use in a cinema environment.

## Important safety guidelines

Learn about the safety precautions related to the Christie Cinema 4K-RGBH projectors. This projector is intended for use in a cinema environment.

### General safety precautions

Read all safety and warning guidelines before installing or operating the projector.



**Warning!** If not avoided, the following could result in death or serious injury.

- TRIP OR FIRE HAZARD! Position all cables where they cannot contact hot surfaces, be pulled, be tripped over, or damaged by persons walking on or objects rolling over the cables.
- This product must be installed within a restricted access location not accessible by the general public.
- Only personnel who are trained on the precautions for the restricted access location can be granted entry to the area.
- Install the product so users and the audience cannot enter the restricted area at eye level.
- ELECTRICAL and BURN HAZARD! Use caution when accessing internal components. Wait for the product to cool down before accessing the internal components for installation, service, or performing optical adjustments.
- High leakage current present when connected to IT power systems.
- FIRE AND SHOCK HAZARD! Use only the attachments, accessories, tools, and replacement parts specified by Christie.
- FIRE HAZARD! Do not use a power cord, harness, or cable that appears damaged.
- A minimum of four people or appropriately rated lift equipment is required to safely lift, install, or move the product.
- Do not install or operate the projector in any position that does not meet the stated product specifications for alignment and orientation.
- RADIATION HAZARD! Use of controls or adjustments, or performing procedures other than those specified may result in hazardous radiation exposure.



**Caution!** If not avoided, the following could result in minor or moderate injury.

- Only Christie qualified technicians are permitted to open product enclosures.

## Laser safety precautions

Read all safety and warning guidelines before operating the projector laser.



**Warning!** If not avoided, the following could result in death or serious injury.

- Do not operate the cinema projector without all of its covers in place.
- LASER RADIATION HAZARD! This projector has a built-in Class 4 laser module. Never attempt to disassemble or modify the laser module.
- Do not look directly into the lens when the light source is on. The extreme high brightness can cause permanent eye damage.
- Possible hazardous optical radiation emitted from this product. (Risk group 3)

## AC power precautions

Read all safety and warning guidelines before connecting to AC power.



**Warning!** If not avoided, the following could result in death or serious injury.

- SHOCK HAZARD! Only use the AC power cord provided with the product or recommended by Christie.
- FIRE AND SHOCK HAZARD! Do not attempt operation unless the power cord, power socket, and power plug meet the appropriate local rating standards.
- SHOCK HAZARD! Do not attempt operation if the AC supply is not within the specified voltage and current, as specified on the license label.
- SHOCK HAZARD! The UPS power cord must be inserted into an outlet with grounding.
- SHOCK HAZARD! Disconnect the product from AC before installing, moving, servicing, cleaning, removing components, or opening any enclosure.
- Install the product near an easily accessible AC receptacle.



**Caution!** If not avoided, the following could result in minor or moderate injury.

- FIRE HAZARD! Do not use a power cord, harness, or cable that appears damaged.
- FIRE OR SHOCK HAZARD! Do not overload power outlets and extension cords.
- SHOCK HAZARD! Power supply uses double pole/neutral fusing.

## Light intensity hazard distance

This projector has been classified as Risk Group 3 as per the IEC 62471-5:2015 standard due to possible hazardous optical and thermal radiation being emitted.



**Warning!** If not avoided, the following could result in serious injury.

- PERMANENT/TEMPORARY BLINDNESS HAZARD! No direct exposure to the beam must be permitted. Class 1 Laser Product - Risk Group 3 according to IEC 60825-1:2014 and IEC 62471-5:2015.
- PERMANENT/TEMPORARY BLINDNESS HAZARD! Operators must control access to the beam within the hazard distance or install the product at the height that prevents exposure of spectators' eyes within the hazard distance. The hazard and no access zones are based on the type of venue the projector is installed in. For restrained environments, the hazard zone must be no lower than 2.5 meters/8.2 feet (US installations) or 2.0 meters/6.6 feet (global installations) above any surface upon which any persons are permitted to stand and the horizontal clearance to the hazard zone must be a minimum 1.0 meters (3.3 feet). For unrestrained environments, the hazard zone must be no lower than 3.0 meters (9.8 feet) above the floor and the horizontal clearance to the hazard zone must be a minimum 2.5 meters (8.2 feet).
- EXTREME BRIGHTNESS! Do not place reflective objects in the product light path.

The following show the zones for ocular and skin hazard distances.

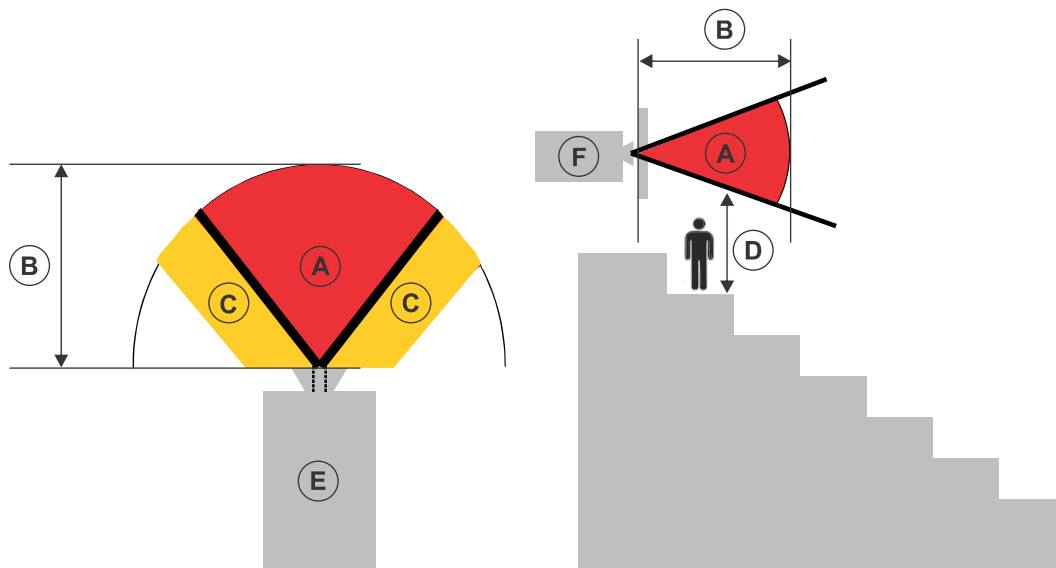

- A—Hazard zone. The region of space where the projection light from the projector is above emission limits for Risk Group 2. The light intensity may cause eye damage after a momentary or brief exposure (before a person can avert their eyes away from the light source). The light may cause skin burns to occur.
- B—Hazard distance. Operators must control access to the beam within the hazard distance or install the product preventing potential exposure of the spectators' eyes from being in the hazard distance.
- C—No access zone. The no access zone must be followed based on the type of venue the projector is installed in.
  - For restrained environments like theaters and facilities where the audience is controlled with formal structures, supervision, or physical constraints, the no access zone must be no less than 1.0 meters (3.3 feet).

- For unrestrained environments like a concert venue or facility that has actions by individuals that are not controlled or guided by formal structures, supervision, or physical constraints and therefore may include unexpected actions that increase the likelihood of accidental hazardous exposure to optical radiation, the no access zone must be no less than 2.5 meters (8.2 feet).
- D—Vertical distance to hazard zone. The hazard zone above the floor must be followed based on the type of venue the projector is installed in.
  - For restrained environments like theaters and facilities where the audience is controlled with formal structures, supervision, or physical constraints, the hazard zone must be no lower than 2.5 meters/8.2 feet (US installations) or 2.0 meters/6.6 feet (global installations) above any surface upon which any persons are permitted to stand.
  - For unrestrained environments like a concert venue or facility that has actions by individuals that are not controlled or guided by formal structures, supervision, or physical constraints and therefore may include unexpected actions that increase the likelihood of accidental hazardous exposure to optical radiation, the hazard zone must be no lower than 3.0 meters (9.8 feet) above the floor.

If the vertical distance to hazard zone requirement (Zone D) is satisfied, the horizontal clearance distance (Zone C) is not needed.

- E—Represents the top view of the projector.
- F—Represents the side view of the projector.

The following give the hazard distance for the projector lens with the zoom adjusted to its most hazardous position.

**Hazard distance graph for CP4410m-RGBH lenses**

Projection lens	Part number	Hazard distance (m)	Category
<b>High brightness (HB) zoom</b>			
1.05:1	108-319104-XX	N/A	RG2
1.2-1.75:1	108-350109-XX	See hazard distance graph below	RG3
1.39-1.9:1	108-327103-XX		
1.5-2.2:1	108-329105-XX		
1.75-2.4:1	108-321107-XX		
1.9-3.0:1	108-328104-XX		
2.4-3.9:1	108-322108-XX		
<b>Ultra high contrast (UHC) zoom</b>			
1.2-1.75:1	163-165103-XX	N/A	RG2
1.39-1.9:1	163-152109-XX	See hazard distance graph below	RG3
1.5-2.2:1	163-166104-XX		
1.75-2.4:1	163-153100-XX		

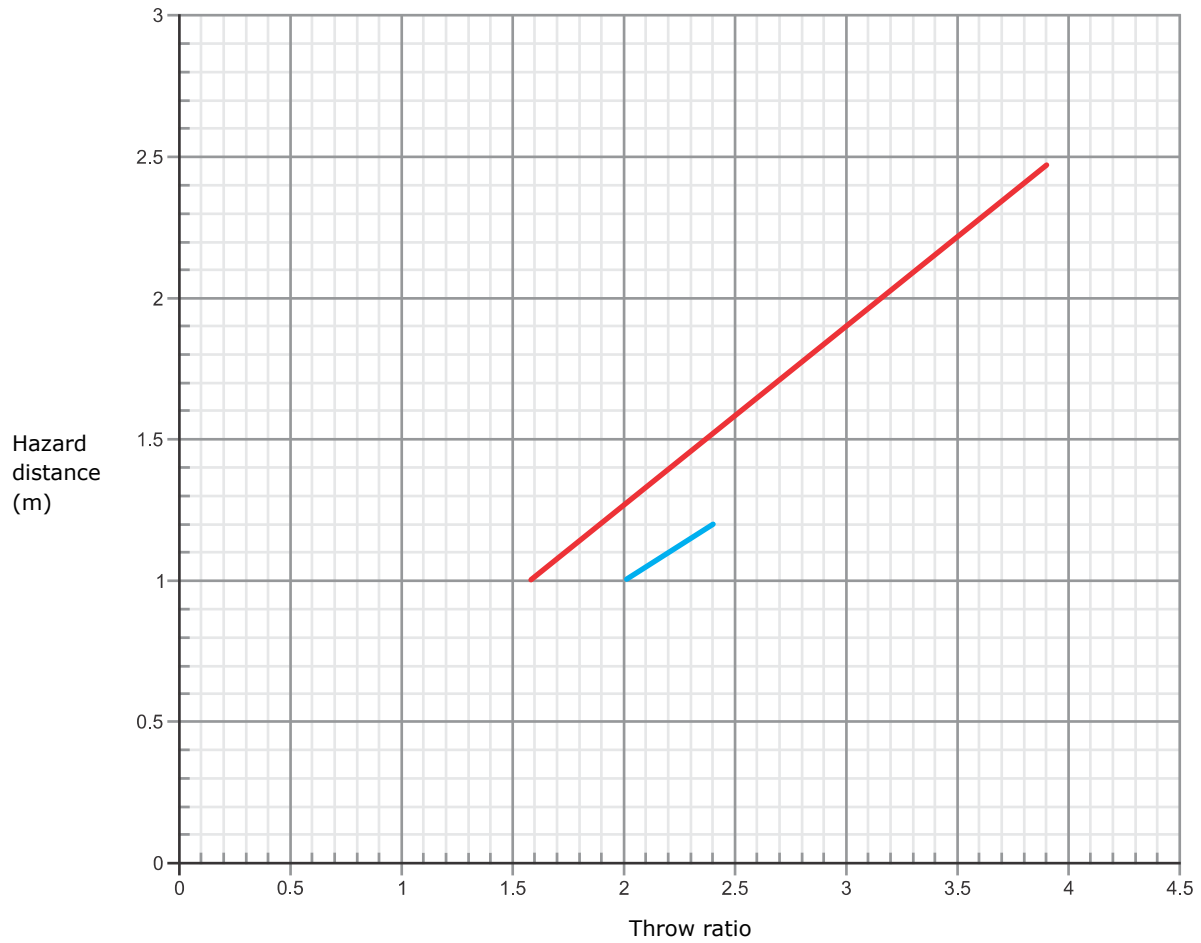

- High brightness lenses
- Ultra high contrast

Due to the requirements of IEC 62471-5, a minimum of 1 meter hazard distance must be maintained.

**Hazard distance graph for CP4415m-RGBH lenses**

Projection lens	Part number	Hazard distance (m)	Category
<b>High brightness (HB) zoom</b>			
1.05:1	108-319104-XX	N/A	RG2
1.2-1.75:1	108-350109-XX	See hazard distance graph below	RG3
1.39-1.9:1	108-327103-XX		
1.5-2.2:1	108-329105-XX		
1.75-2.4:1	108-321107-XX		
1.9-3.0:1	108-328104-XX		
2.4-3.9:1	108-322108-XX		

Projection lens	Part number	Hazard distance (m)	Category
<b>Ultra high contrast (UHC) zoom</b>			
1.2-1.75:1	163-165103-XX	See hazard distance graph below	RG3
1.39-1.9:1	163-152109-XX		
1.5-2.2:1	163-166104-XX		
1.75-2.4:1	163-153100-XX		

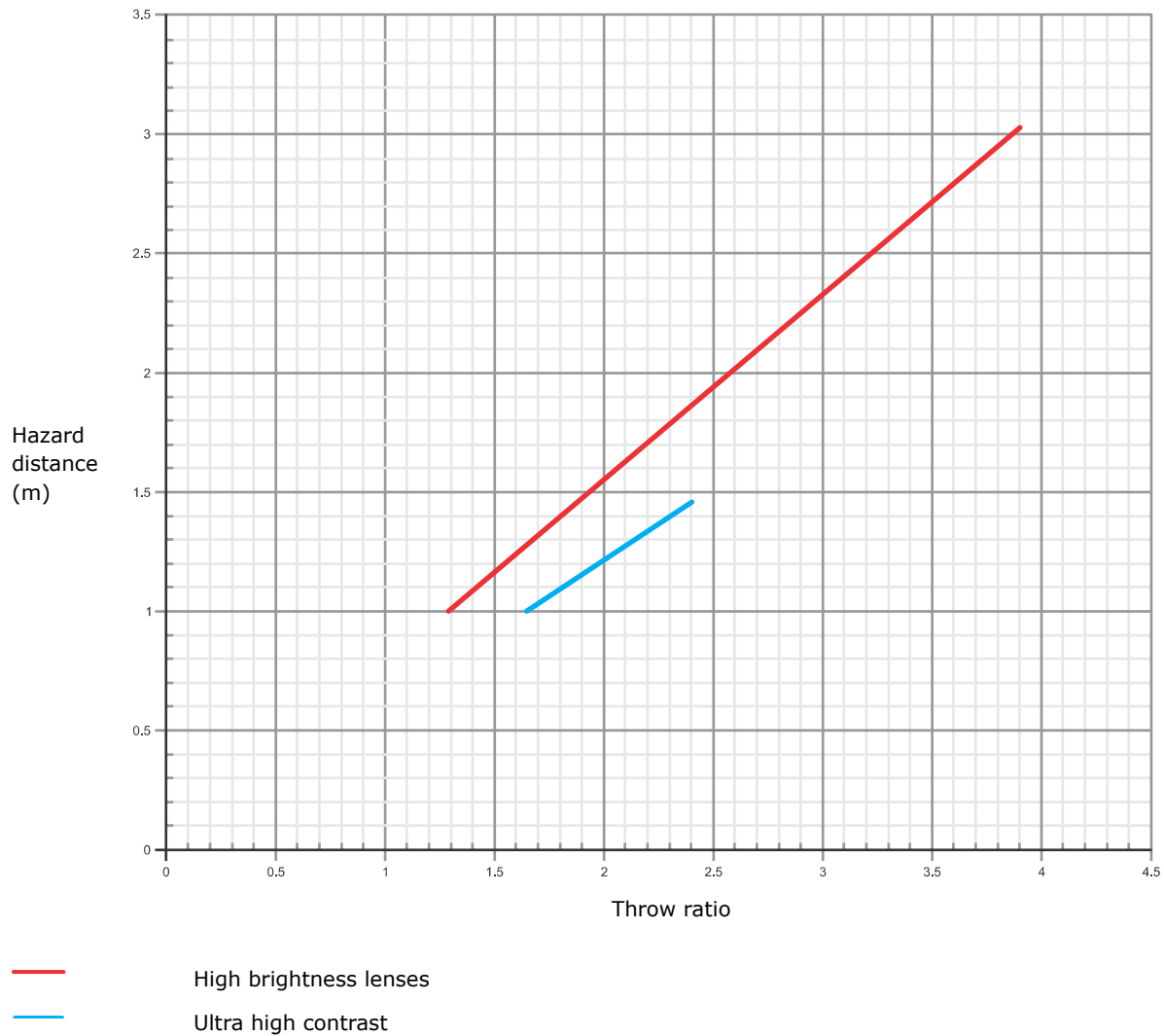

Due to the requirements of IEC 62471-5, a minimum of 1 meter hazard distance must be maintained.

**Hazard distance graph for CP4420m-RGBH lenses**

Projection lens	Part number	Hazard distance (m)	Category
<b>High brightness (HB) zoom</b>			

Projection lens	Part number	Hazard distance (m)	Category
1.05:1	108-319104-XX	N/A	RG2
1.2-1.75:1	108-350109-XX	See hazard distance graph below	RG3
1.39-1.9:1	108-327103-XX		
1.5-2.2:1	108-329105-XX		
1.75-2.4:1	108-321107-XX		
1.9-3.0:1	108-328104-XX		
2.4-3.9:1	108-322108-XX		
<b>Ultra high contrast (UHC) zoom</b>			
1.2-1.75:1	163-165103-XX	See hazard distance graph below	RG3
1.39-1.9:1	163-152109-XX		
1.5-2.2:1	163-166104-XX		
1.75-2.4:1	163-153100-XX		

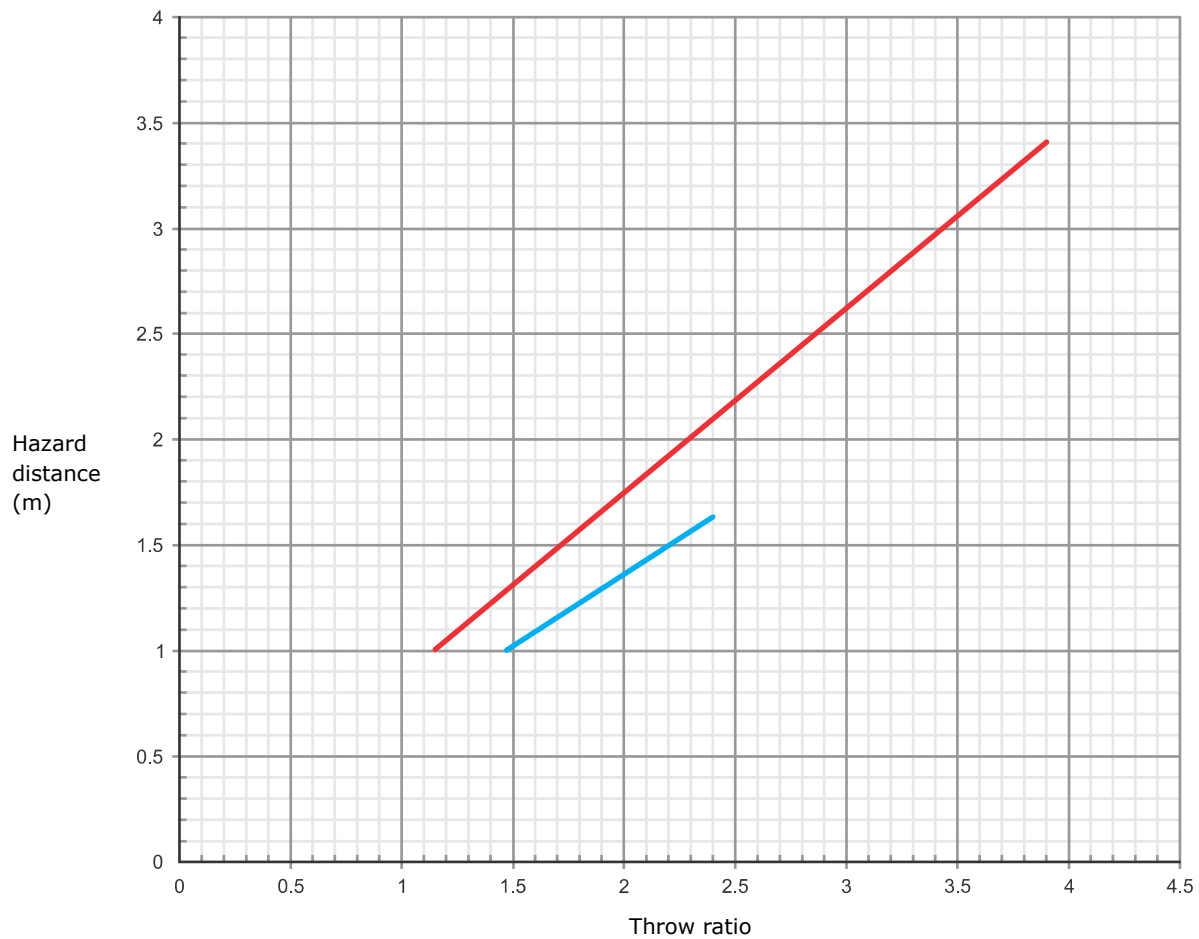

- High brightness lenses
- Ultra high contrast

Due to the requirements of IEC 62471-5, a minimum of 1 meter hazard distance must be maintained.

### Stacking projectors

When two projectors are stacked (projecting on the same surface), due to the overlap of the images, a system hazard distance may need to be applied instead of a single projector hazard distance. When projectors are being stacked in two-dimension (for example 2x2), only projectors stacked along one axis (horizontal or vertical) should be considered, taking the stacking direction with the shortest lens distance (center-to-center distance) to reduce to separate two systems.

The following information is required:

HD	Hazard distance of a single projector with the given lens (center-to-center distance)
h	Distance between two adjacent projector lenses in the stack

1. Determine the hazard distance (HD) of a single projector with a given lens and the distance (h) between the adjacent lenses.

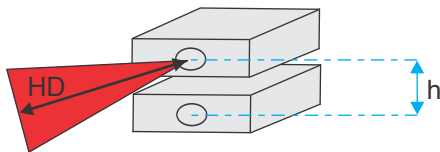

2. Determine the hazard distance for stacking two projectors:
  - If the single projector hazard distance is  $HD \geq 9 \times h$ , implement  $1.15 \times HD$  for the hazard distance.
  - If the single projector hazard distance is  $HD < 9 \times h$ , keep the original hazard distance and risk zone as per the projector.

### For Installations in the United States

The following must be in place for laser-illuminated projector installations in the United States:



- Any human access to the hazard zone, if applicable, must be restricted by barriers to enforce the no access zone.
- The projection room shall be clearly identified by the posting of laser warning and restricted access signs, and by restricting entry through physical means. The projection room sign must display the warning "No direct exposure to beam shall be permitted".
- The Christie Laser Projection System Installation Checklist must be fully completed after the installation and sent to [lasercompliance@christiedigital.com](mailto:lasercompliance@christiedigital.com). A copy can remain on-site. This checklist can be found as a separate document in the accessory box with the manual.
- Certain US states have additional laser regulatory requirements. Contact [lasercompliance@christiedigital.com](mailto:lasercompliance@christiedigital.com) for additional regulatory requirements.

## Product labels

Learn about the labels that may be used on the product. Labels on your product may be yellow or black and white.

## General hazards

Hazard warnings also apply to accessories once they are installed in a Christie product connected to power.

Fire and Shock Hazard	
	<p>To prevent fire or shock hazards, do not expose this product to rain or moisture. Do not alter the power plug, overload the power outlet, or use it with extension cords. Do not remove the product enclosure. Only Christie qualified technicians are authorized to service the product.</p>
Electrical Hazard	
	<p>Risk of electric shock. Do not remove the product enclosure. Only Christie qualified technicians are authorized to service the product.</p>



**Warning!** If not avoided, the following could result in death or serious injury.



Electric shock hazard. To avoid personal injury, disconnect all power sources before performing maintenance or service.



Electrocution hazard. To avoid personal injury, always disconnect all power sources before performing maintenance or service procedures.



Optical radiation hazard. To avoid personal injury, never look directly at the light source.



Voltage hazard. To avoid personal injury, always disconnect all power sources before performing maintenance or service procedures.



**Caution!** If not avoided, the following could result in minor or moderate injury.



General hazard.



Hot surface hazard. To avoid personal injury, allow the product to cool for the recommended cool down time before touching or handling for maintenance or service.



Burn hazard. To avoid personal injury, allow the product to cool for the recommended cool down time before touching or handling for maintenance or service.



Moving parts hazard. To avoid personal injury, keep hands clear and loose clothing tied back.



Moving fan blades. To avoid personal injury, keep hands clear and loose clothing tied back. Always disconnect all power sources before performing maintenance or service procedures.



Cut hazard. To avoid personal injury, keep hands clear or wear protective gloves.



**Notice.** If not avoided, the following could result in property damage.



General hazard.



Not for household use.

## Mandatory actions



**Caution!** If not avoided, the following could result in minor or moderate injury.



Consult the service manual.



Disconnect all power sources before performing maintenance or service procedures.

## Electrical labels



Indicates the presence of a protective earth ground.



Indicates the presence of an earth ground.

## Additional hazard labels



Indicates high leakage current. Earth or ground connection essential before connecting the power supply.



Indicates a light hazard. Do not look directly into the lens. The extreme high brightness can cause permanent eye damage.

## Laser labels

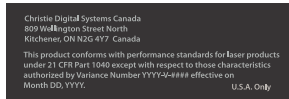

CP4410m-RGBH, CP4415m-RGBH, and CP4420m-RGBH laser variance (US projectors only)

This product is in conformity with performance standards for laser products under 21 CFR 1040, except with respect to those characteristics authorized by Variance Number 2016-V-1838 effective on December 4, 2018.



CLASS 1 LASER PRODUCT IEC 60825-1:2014

CP4410m-RGBH wavelengths: 449 nm - 651 nm

CP4415m-RGBH wavelengths: 449 nm - 651 nm

CP4420m-RGBH wavelengths: 449 nm - 647 nm

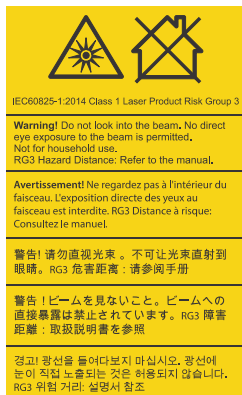

Indicates a light hazard. Do not look directly into the lens. The extreme high brightness can cause permanent eye damage.

Class 1 Laser Product - Risk Group 3 according to IEC 60825-1:2014 and IEC 62471-5:2015



Indicates Class 4 laser radiation when open. Avoid eye or skin exposure to direct or scattered radiation.

# Introduction

This manual is intended for professionally trained operators of Christie high-brightness Cinema 4K-RGBH projection systems.

Only trained Christie qualified technicians who are knowledgeable about the hazards associated with high-voltage, laser safety, and the high temperatures generated by the projector are authorized to assemble and install the projector. Only Christie qualified technicians are authorized to service the projector.

For complete product documentation and technical support, go to [www.christiedigital.com](http://www.christiedigital.com).

## Models

This guide applies to the following models.

- CP4410m-RGBH
- CP4415m-RGBH
- CP4420m-RGBH

## What's new in the guide?

The following updates have been made to the guide.

- Added the Liquid cooling interconnect drawing to the *Related documentation* (on page 21) topic.
- Updated the following topics:
  - *Lifting and positioning the projector* (on page 26)
  - *Connecting to an uninterruptible power supply* (on page 34)
- Added the following topics:
  - *Checking for the latest software version* (on page 43)
  - *Performing a backup* (on page 70)

## Projector overview

Learn about the Cinema 4K-RGBH projector.

The Cinema 4K-RGBH Series features CineLife+™ electronics and hybrid laser phosphor/RGB illumination. The Cinema 4K-RGBH Series is a compact, all-in-one DCI-compliant projector, which excels in image quality and operational lifetime while providing a low total cost of ownership. With the Cinema 4K-RGBH, exhibitors can impress audiences with incredibly colorful and detailed, true-to-life images while benefiting from an affordable platform that will perform well into the future.

## Key features

Understand the important features of the projector.

- Hybrid laser phosphor/RGB laser illumination
- Three-chip 0.98 inch 4K SST light engine
- Christie CineLife+™ Series 4 electronics
- Ability to work with Mystique™ software
- LiteLOC™ feature for constant image brightness and color with hybrid light source
- Sealed optical path
- All-in-one design, including lasers and cooling
- Compatible with existing lens suite

## List of included accessories

Verify all components were received with the projector.

- High security key to open the projector top cover
- Cable tie straps—quantity 3
- Lens locking screws—quantity 2
- Laser safety signs

## Accessories

Learn about the accessories (sold separately) available for the projector.

### Lenses



If using a shorter throw lens and switching between dark and light content, focus drift can occur.

Projection lens	Part number
<b>High brightness (HB)</b>	
1.05:1 DLPCine HB zoom lens	108-319104-XX
1.2-1.75:1 DLPCine HB zoom lens	108-350109-XX
1.39-1.9:1 DLPCine HB zoom lens	108-327103-XX
1.5-2.2:1 DLPCine HB zoom lens	108-329105-XX
1.75-2.4:1 DLPCine HB zoom lens	108-321107-XX
1.9-3.0:1 DLPCine HB zoom lens	108-328104-XX
2.4-3.9:1 DLPCine HB zoom lens	108-322108-XX
<b>Ultra high contrast (UHC)*</b>	
1.2-1.75:1 DLPCine UHC zoom lens	163-165103-XX

Projection lens	Part number
1.39-1.9:1 DLPCine UHC zoom lens	163-152109-XX
1.5-2.2:1 DLPCine UHC zoom lens	163-166104-XX
1.75-2.4:1 DLPCine UHC zoom lens	163-153100-XX



\*When using a UHC lens, make sure to *select the appropriate lens type* (on page 40) in the web user interface.

### Filters and coolant

Description	Part number
Air intake filter (1 pack)	003-007742-XX
Coolant Propylene Glycol 740	003-005179-XX

### UPS power cord (optional)

Description	Part number	Cord type
250 V/10 A C13 3 m–Australia and New Zealand	108-593108-XX	Straight locking cord
	108-624103-XX	Right-angle cord
250 V/10 A C13 3 m–China	108-587101-XX	Straight locking cord
	108-619107-XX	Right-angle cord
250 V/10 A C13 3 m–Europe	108-590105-XX	Straight locking cord
	108-622101-XX	Right-angle cord
250 V/10 A C13 3 m–India	108-591106-XX	Straight locking cord
250 V/15 A C13 3 m–Japan	108-588102-XX	Straight locking cord
	108-620109-XX	Right-angle cord
125 V/15 A C13 2.5 m–Japan and Taiwan	108-507103-XX	Standard non-locking cord
250 V/10 A C13 3 m–Korea	108-590105-XX	Straight locking cord
	108-623102-XX	Right-angle cord
250 V/15 A C13 3 m–North America	108-586100-XX	Straight locking cord
	108-599104-XX	Straight locking cord
125 V/15 A C13 3 m–North America	108-618106-XX	Right-angle cord
250 V/10 A C13–South Africa	108-592107-XX	Straight locking cord
250 V/10 A C13 3 m–United Kingdom	108-589103-XX	Straight locking cord
	108-621100-XX	Right-angle cord



The right-angle line cords are available for compact spaces and when the AC inputs are configured to route from the front or rear of the unit.

### Other accessories

Description	Part number
Adjustable rack stand	108-416102-XX
Rack adapter kit	153-146102-XX
Exhaust duct	153-147103-XX
Touch panel	163-151108-XX

## Projector components

Identify the main components of the projector.



The illustrations in this topic are for representation only and may not depict your projector model exactly.

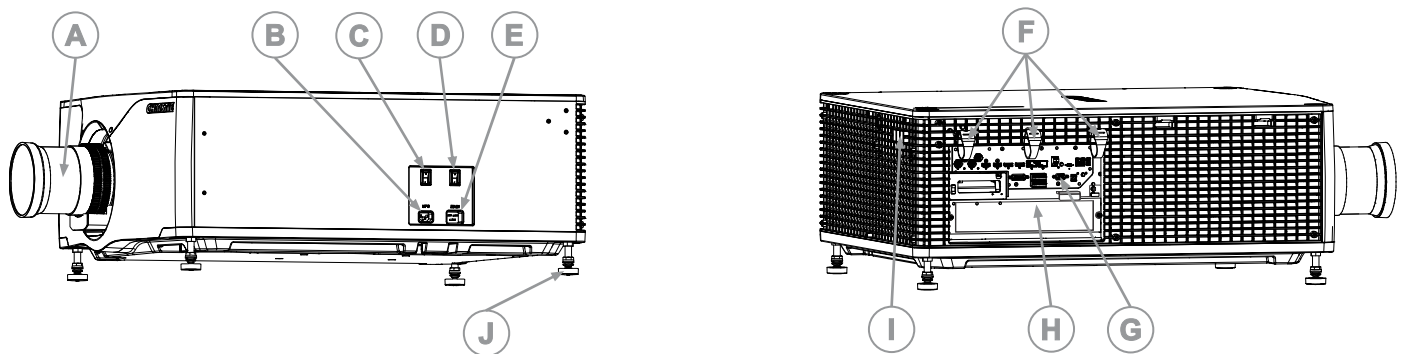

ID	Component	Description
A	Projector lens	A variety of lenses can be used with the projector. Available lenses are listed in <i>Accessories</i> (on page 18).
B	UPS input	Allows the projector electronics to remain operable during a power failure.
C	UPS circuit breaker	Switch to power the projector on or off.
D	Main circuit breaker	Switch to power the projector on or off.
E	Main input	Provides a connection to AC power.
F	Cable management straps	Use to manage cables. The provided cable tie straps can be installed if required.
G	Communications panel	Connect media sources to the Video Input panel.
H	Integrated Media Block (IMB)	Slot for the Integrated Media Block (IMB).
I	Status LED	Indicate the status of the projector.
J	Adjustable feet	Turn the adjustable feet to increase or decrease the projector height.

## Related documentation

Additional information on the projector is available in the following documents.

- *CineLife+ 2.0 User guide (P/N: 020-103845-XX)*
- *CP4410m-RGBH, CP4415m-RGBH, and CP4420m-RGBH Service guide (P/N: 020-103944-XX)*
- *CineLife+ Serial Commands guide (P/N: 020-103075-XX)*
- *CineLife+ Supported Video Formats technical reference (P/N: 020-104085-XX)*
- *CP44xxm-RGBH Line drawing (P/N: 020-104118-XX)*
- *CP4420m-RGBH Interconnect drawing (P/N: 020-104133-XX) and CP441xm-RGBH Interconnect drawing (P/N: 020-104135-XX)*
- *CP4415m-RGBH and CP4420m-RGBH liquid cooling interconnect drawing (P/N: 020-104156-XX)*

## Accessing the product documentation

For installation, user, and service information, see the product documentation available on the Christie website. Read all instructions before installing, using, or servicing this product.

1. Access the documentation from the Christie website:
  - Go to one of the following URLs:
    - <https://bit.ly/3vxrm4Y>
    - <https://www.christiedigital.com/products/cinema/projection/cinelife-plus-series/>
  - Scan the QR code using a QR code reader app on a smartphone or tablet.



2. To access service information, sign into the Partner Portal.
3. On the product page, select the model and switch to the **Downloads** tab.

## Downloading interconnect and line drawings

The interconnect diagram illustrates the path of electrical connections between modules. Manufacturer's part numbers are included. Part numbers are subject to change.

Line drawings provide product dimensions and sizes for installation.

To download the latest interconnect diagram or line drawings:

1. Go to [www.christiedigital.com](http://www.christiedigital.com).
2. Sign into the Partner Portal.
3. Navigate to your model.
4. Switch to the **Downloads** tab and expand **Line drawings** section.



If the interconnect diagram or line drawings are not available on the Christie website, contact Christie Technical Support.

## Downloading preventative maintenance schedules

Preventative maintenance is an important part of the continued and proper operation of your product. Failure to perform maintenance as required and according to the maintenance schedule specified by Christie voids the warranty.

If you require more information, contact Christie Technical Support.

To download the latest preventative maintenance schedule:

1. Go to [www.christiedigital.com](http://www.christiedigital.com).
2. Sign into the Partner Portal.
3. Navigate to your model.
4. Switch to the **Downloads** tab and expand **Service manual** section.

## Cinema calculator tool

Use Christie's cinema calculator tool to determine the right projector, lens, and lamp based on the unique needs of your installation, as well as your preferred projector type, screen configuration, and brightness requirements.

To learn more and use the tool, go to <https://cinemaster.christiedigital.com/>.

## Viewing Christie University product training videos

Christie University provides select product training videos that are helpful for understanding and using your product.

To view the available videos for your product:

1. Go to Christie University: <https://training.christiedigital.com>.
2. Select **I'm a Christie partner or customer**.
3. Log into your profile.
4. Select **Catalog**.
5. Select **Videos**.
6. Select **Product Training Videos**.
7. Navigate to the folder for your product.

## Contact your dealer

Record the information about your installation and keep this information with your records to assist with any servicing of your product. If you encounter a problem, contact your dealer.

Purchase record
Dealer:
Dealer or Christie Sales/Service contact phone number:

<b>Purchase record</b>
<p>Serial number: The serial number can be found on the license label.</p>
<p>Purchase date:</p>
<p>Installation date:</p>

## Technical support

Technical support for Christie Cinema products is available at:

- [Support.cinema@christiedigital.com](mailto:Support.cinema@christiedigital.com)
- +1-877-334-4267

# Installing and setting up

Learn how to position and install the projector.

## Site requirements

To safely install and operate the Cinema 4K-RGBH projectors, the installation location must meet these minimum requirements.

### Physical operating environment

- Ambient temperature (operating): 10 to 35°C (50 to 95°F) up to 1000 meters (3280.8 feet) above sea level
- Humidity (non-condensing): 10% to 80%
- Operating altitude: 0 to 3000 meters (0 to 9843 feet) at 10 to 25°C (50 to 77°F)
- Site cleanliness: ISO Class 9 or cleaner

### Product ventilation

Sufficient ventilation is required around the projector to regulate the temperature of the internal laser module. If necessary, air intake and exhaust HVAC ducts can be installed.

An exhaust duct is also available for purchase as an optional accessory (P/N: 153-147103-XX). Instructions for installing the exhaust duct are included with the accessory part.

The installation site must provide the following:

- For CP4410m-RGBH, an airflow of 120 cubic feet per minute (CFM) at 1 to 1000 meters elevation, and must accommodate a heat load (nominal/maximum) of 2930/10920 BTU/hr
- For CP4415m-RGBH, an airflow of 120 cubic feet per minute (CFM) at 1 to 1000 meters elevation, and must accommodate a heat load (nominal/maximum) of 3620/10920 BTU/hr
- For CP4420m-RGBH, an airflow of 120 cubic feet per minute (CFM) at 1 to 1000 meters elevation, and must accommodate a heat load (nominal/maximum) of 4640/10920 BTU/hr



For each additional 1000 meters above sea level, increase the airflow (CFM) value by 15%. If an extraction duct is not used, the operating temperature range is restricted to 10 to 25°C (50 to 77°F) at a maximum altitude of 3000 meters.

### Power connection

The projector requires an AC connection to operate. There is also an available connector for an uninterruptible power supply (UPS) to provide backup power for the projector electronics only. The projector requires an internal connection to switch between the two operational modes: Main only and Main plus UPS.

Certified wall breakers are required as part of the installation. Breakers must be part of the building and easily accessible. The size of the breaker is determined from the power requirements of the

projector and can be up to 20A maximum for the main input and up to 15A maximum for the UPS input.

## Power requirements

Learn the power requirements for the projector.

Item	Main input	UPS input
Voltage range	200-240 VAC	100-240 VAC
Maximum current	16 A	6.5 A
Line frequency	50/60 Hz	50/60 Hz

## Best practices when installing a projector

Christie recommends the following best practices when installing Cinema 4K-RGBH projectors.

- Download and use the most recent version of the installation and setup guide for your projector from the Christie website.
- Review all available courses on Christie University pertaining to your projector model or safety information.
- Make sure the required tools are available.
- Partially thread screws into their holes to ensure they are properly aligned and positioned but do not fully tighten until all screws are in place.
- Use high caliber cables to ensure the quality of the content (signals). Poor quality cables can affect the performance of the cable and quality of the video.
- Make sure cables are properly strain relieved so they do not apply unnecessary force on the board connectors.
- Let the projector and its components acclimatize to the installation environment.
- Update software when new software updates are available.

For details, see the *CineLife+ 2.0 User guide (P/N: 020-103845-XX)*.

## Preparing the installation site

Make sure the installation area is ready for the components.

1. Clear the installation area.
2. Post laser hazard warning signs at all entry doors.
3. Let the projector and its components acclimatize to the installation environment.
4. Place each component near its installation location.
5. Make sure the required tools are available.

## Lifting and positioning the projector

Safely lift and position the projector in the location where it will be used.



**Warning!** If not avoided, the following could result in death or serious injury.

- Do not install or operate the projector in any position that does not meet the stated product specifications for alignment and orientation.
- A minimum of four people or appropriately rated lift equipment is required to safely lift, install, or move the product.
- Do not install or operate the projector in any position that does not meet the stated product specifications for alignment and orientation.
- Do not stack more than two projectors in landscape orientation.



- Before lifting and positioning the projector, refer to the light intensity hazard distances.
- To avoid damage to the lens mount when lifting the projector, do not apply the load across the front of the projector.

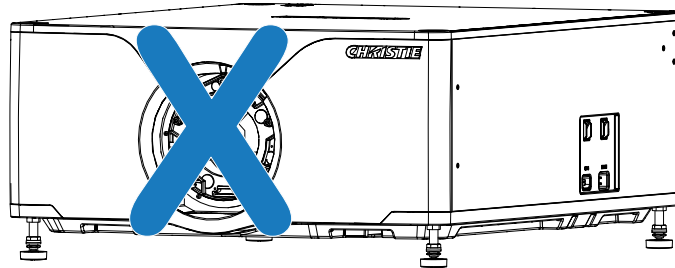

- When lifting the projector, use the projector lifting locations on the bottom cover.

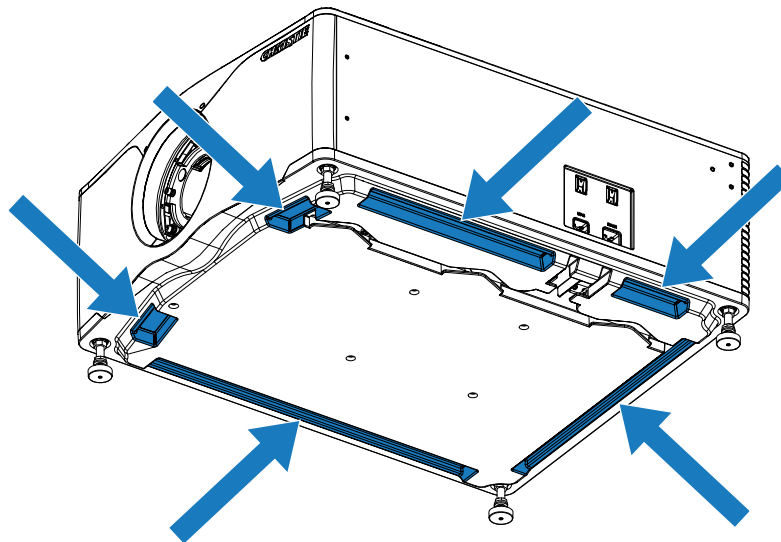

1. If installing the projector in the optional rack stand (P/N: 108-416102-XX), follow the instructions provided with the rack stand and rack stand adapter kit (P/N: 153-146102-XX).
2. Position the projector so it is centered and parallel with the theater screen.  
If space is limited, aim the projector slightly off-center and use lens offset to center the image on the screen.

3. Adjust the projector leveling feet:
  - a) Adjust the projector feet to the shortest height possible while meeting the required projector tilt angle and avoiding unnecessary foot extension height.  
Christie recommends adjusting the pedestal rather than overextending the projector feet.
  - b) If required, raise the bottom projector feet to a maximum of 15° in a downward direction or 5° in an upward direction.  
The side-to-side tilt must be within +3° to -3° of level.
  - c) When adjusting projector angles, confirm opposing feet are adjusted in equal amounts within 4 mm mismatch by measuring each foot extension height.  
Top cover misalignment is an indicator of unequal foot extension.
4. If stacking the projector, complete the following actions:
  - a) Perform all leveling and adjustment procedures from step 3 for the bottom projector, making sure to adhere to the shortest possible height requirement.
  - b) Make sure the bottom projector is level by adjusting the roll of the lens axis to ensure the stability of the stack.

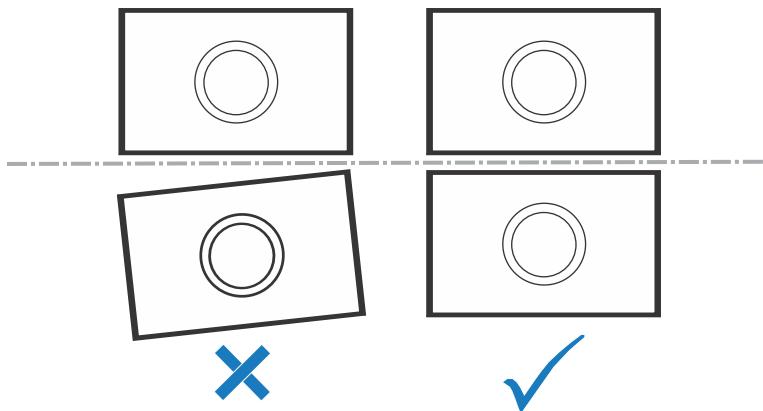

- c) If required, raise the bottom projector feet to a maximum of 15° in a downward direction or 5° in an upward direction.  
The side-to-side tilt must be within +3° to -3° of level.  
The projector feet must be at their shortest height to meet the required projector tilt angle.
- d) Adjust the top projector feet to minimum height, making sure opposing feet mismatch is within 4 mm.
- e) Position the top projector feet into the recessed mounts on the bottom projector top cover.

## Mounting the projector in inverted ceiling position

Cinema 4K-RGBH projector models are capable of being mounted in an inverted position when the environment and components requirements are met.

This mounting procedure must be completed before the lens is installed in the projector.



**Warning!** If not avoided, the following could result in death or serious injury.

- Do not install or operate the projector in any position that does not meet the stated product specifications for alignment and orientation.
  - A minimum of four people or appropriately rated lift equipment is required to safely lift, install, or move the product.
1. Review the line drawings for the projector for ventilation and environment specification information.
  2. Make sure the lens is not installed in the projector.
  3. Make sure the following components are available:
    - Through-hole stand-offs measuring 24 mm in length and 20 to 24 mm across the outer diameter—quantity 4
    - M10 x 1.5 mm bolts that provide a minimum of 20 mm of engagement with the mounting holes and at least class 8.8—quantity 4
    - Flat mounting surface
  4. Verify the mounting surface can support the combined load of the product and meets all local safety standards and regulations.
  5. Remove the top cover of the projector:
    - a) Unlock the cover using the high security key.

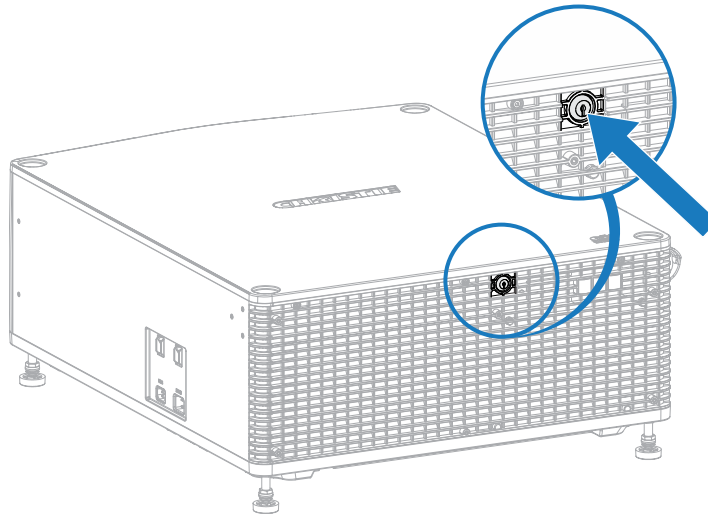

- b) Loosen the five screws (three screws located at the rear of the projector and two screws located at the front of the projector) securing the top cover.

**Three screws located at rear of the projector:**

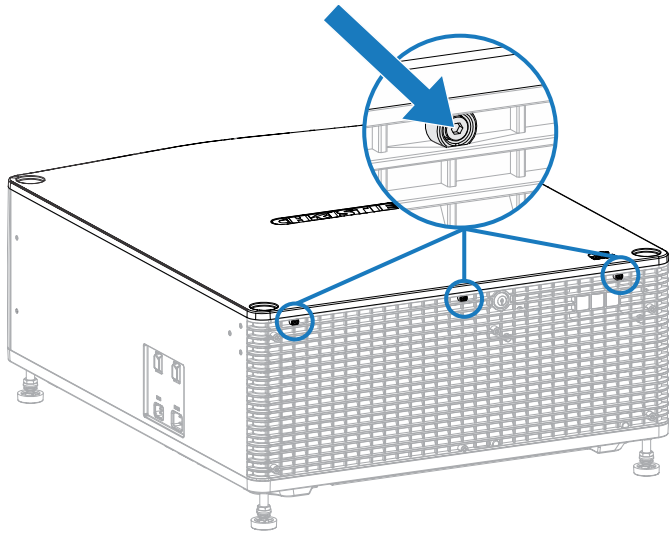

Two screws located at front of the projector:

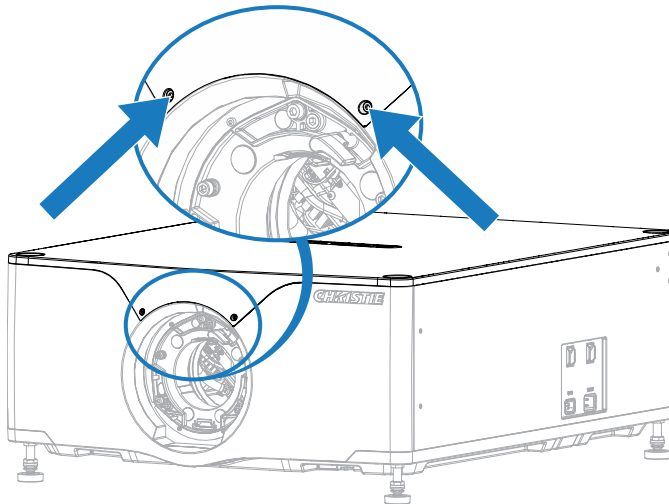

c) Push the cover forward towards the front of the projector.

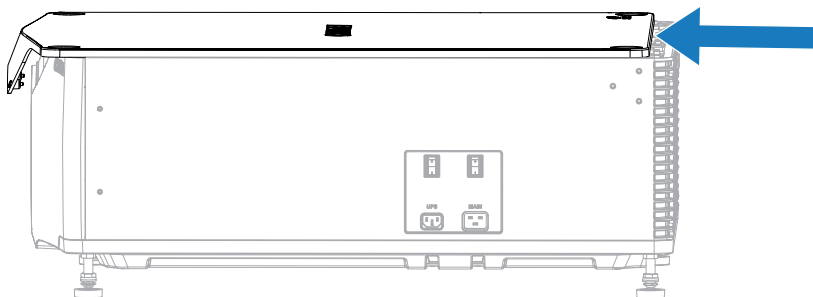

d) Remove the cover.

6. Remove the four screws and washers securing the feet within the projector.

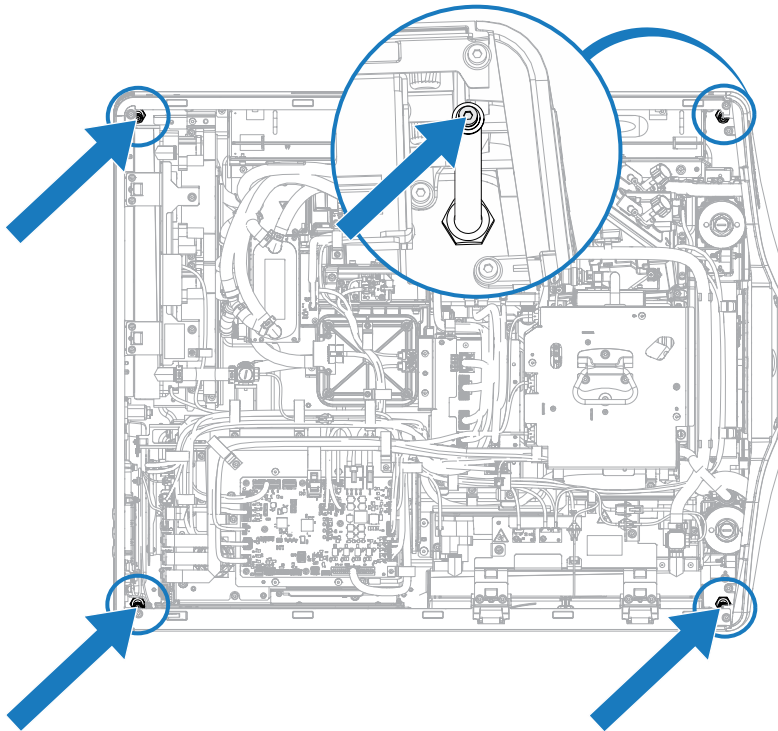

7. Remove the feet from the projector.
8. Rotate the projector upside down.
9. Position the projector to the mounting surface.
10. To secure the projector to the mounting surface, complete the following steps:
  - a) Position the four through-hole stand-offs between the projector and mounting surface.
  - b) Secure the projector to the mounting surface by screwing the four M10 bolts through the feet mounting holes.

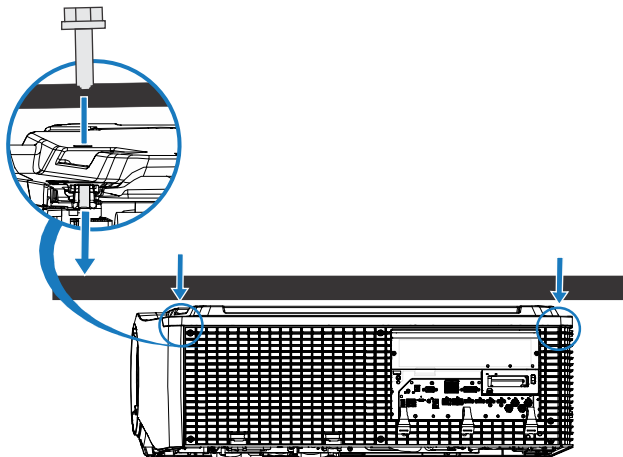

- c) Torque the bolts to 16 ft-lbs.
11. Re-install the top cover.

## Mounting the projector in lens-up position

Cinema 4K-RGBH projector models are capable of being mounted in a lens-up position when the environment and components requirements are met.

This mounting procedure must be completed before the lens is installed in the projector.



**Warning!** If not avoided, the following could result in death or serious injury.

- Do not install or operate the projector in any position that does not meet the stated product specifications for alignment and orientation.
  - A minimum of four people or appropriately rated lift equipment is required to safely lift, install, or move the product.
1. Review the line drawings for the projector for ventilation and environment specification information.
  2. Make sure the lens is not installed in the projector.
  3. Make sure the following components are available:
    - Through-hole stand-offs measuring 24 mm in length and 20 to 24 mm across the outer diameter—quantity 4
    - M10 x 1.5 mm bolts that provide a minimum of 20 mm of engagement with the mounting holes and at least class 8.8—quantity 4
    - Flat mounting surface
  4. Verify the mounting surface can support the combined load of the product and meets all local safety standards and regulations.
  5. Remove the top cover of the projector:
    - a) Unlock the cover using the high security key.

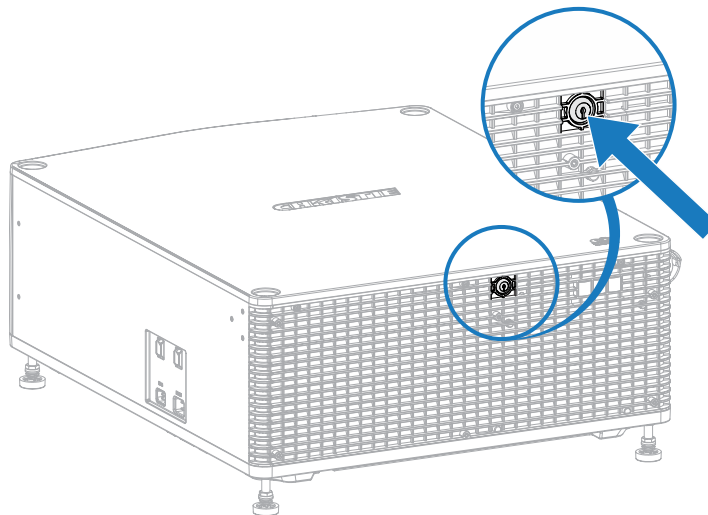

- b) Loosen the five screws (three screws located at the rear of the projector and two screws located at the front of the projector) securing the top cover.

**Three screws located at rear of the projector:**

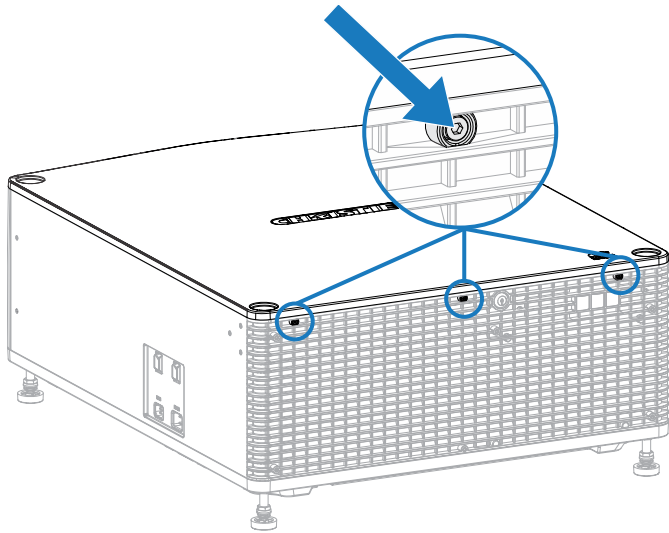

Two screws located at front of the projector:

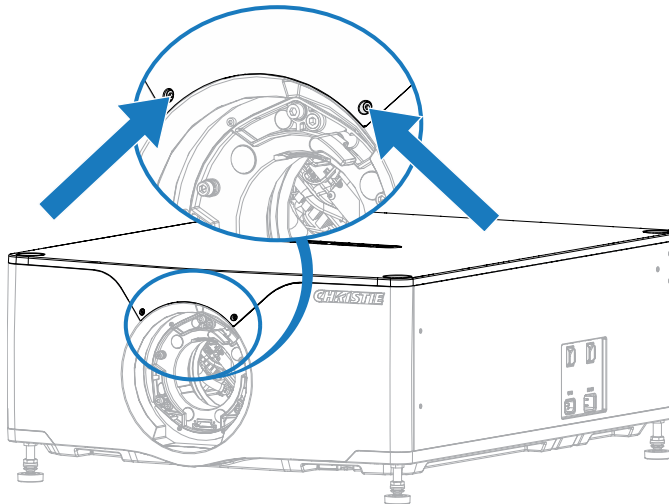

c) Push the cover forward towards the front of the projector.

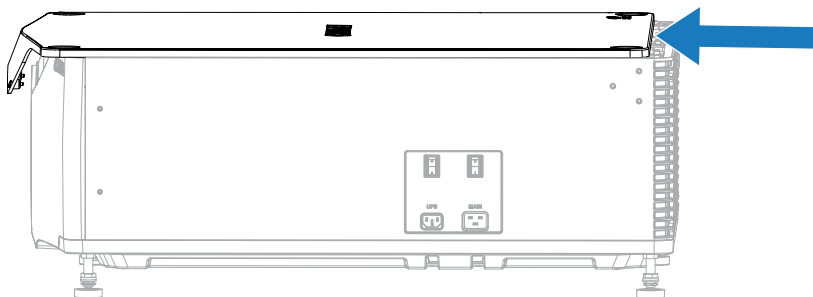

d) Remove the cover.

6. Remove the four screws and washers securing the feet within the projector.

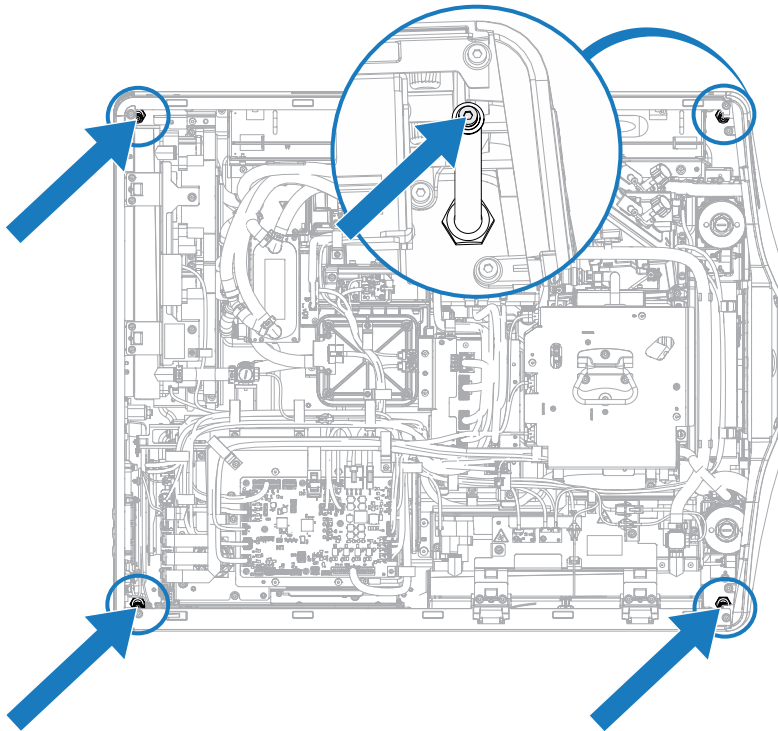

7. Remove the feet from the projector.
8. Rotate the projector so the lens points in an upward direction.
9. Position the projector to the mounting surface.
10. Make sure the airflow distance adheres to the requirements in the line drawing.
11. To secure the projector to the mounting surface, complete the following steps:
  - a) Position the four through-hole stand-offs between the projector and mounting surface.
  - b) Secure the projector to the mounting surface by screwing the four M10 bolts through the feet mounting holes.

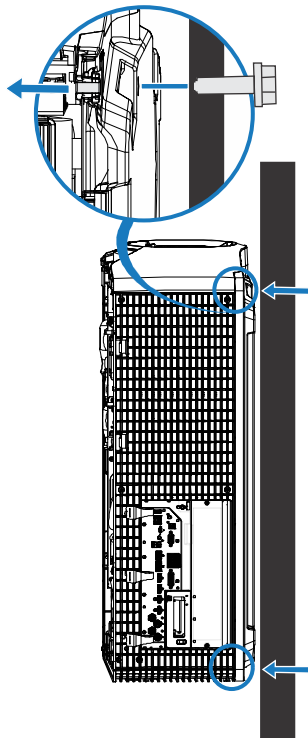

c) Torque the bolts to 16 ft-lbs.

12. Re-install the top cover.

## Connecting to an uninterruptible power supply

An uninterruptible power supply (UPS) allows the cinema projector head electronics to remain operable during a power failure. The projector unit is configured for MAIN input only. To use a UPS, both the MAIN and UPS inputs must be configured for power.



**Warning!** If not avoided, the following could result in death or serious injury.

- SHOCK HAZARD! The UPS power cord must be inserted into an outlet with grounding.
- FIRE HAZARD! Do not use a power cord, harness, or cable that appears damaged.
- FIRE AND SHOCK HAZARD! Do not attempt operation unless the power cord, power socket, and power plug meet the appropriate local rating standards.
- SHOCK HAZARD! Do not attempt operation if the AC supply is not within the specified voltage and current, as specified on the license label.
- A certified electrician must be present during installation to make sure the installation meets the local electrical code.

The following table lists the part numbers for the optional UPS power cords for each region.

Description	Part number	Cord type
250 V/10 A C13 3 m—Australia and New Zealand	108-593108-XX	Straight locking cord
	108-624103-XX	Right-angle cord

Description	Part number	Cord type
250 V/10 A C13 3 m–China	108-587101-XX	Straight locking cord
	108-619107-XX	Right-angle cord
250 V/10 A C13 3 m–Europe	108-590105-XX	Straight locking cord
	108-622101-XX	Right-angle cord
250 V/10 A C13 3 m–India	108-591106-XX	Straight locking cord
250 V/15 A C13 3 m–Japan	108-588102-XX	Straight locking cord
	108-620109-XX	Right-angle cord
125 V/15 A C13 2.5 m–Japan and Taiwan	108-507103-XX	Standard non-locking cord
250 V/10 A C13 3 m–Korea	108-590105-XX	Straight locking cord
	108-623102-XX	Right-angle cord
250 V/15 A C13 3 m–North America	108-586100-XX	Straight locking cord
	108-599104-XX	Straight locking cord
125 V/15 A C13 3 m–North America	108-618106-XX	Right-angle cord
250 V/10 A C13–South Africa	108-592107-XX	Straight locking cord
250 V/10 A C13 3 m–United Kingdom	108-589103-XX	Straight locking cord
	108-621100-XX	Right-angle cord



The right-angle line cords are available for compact spaces and when the AC inputs are configured to route from the front or rear of the unit.

**Power connections diagram**

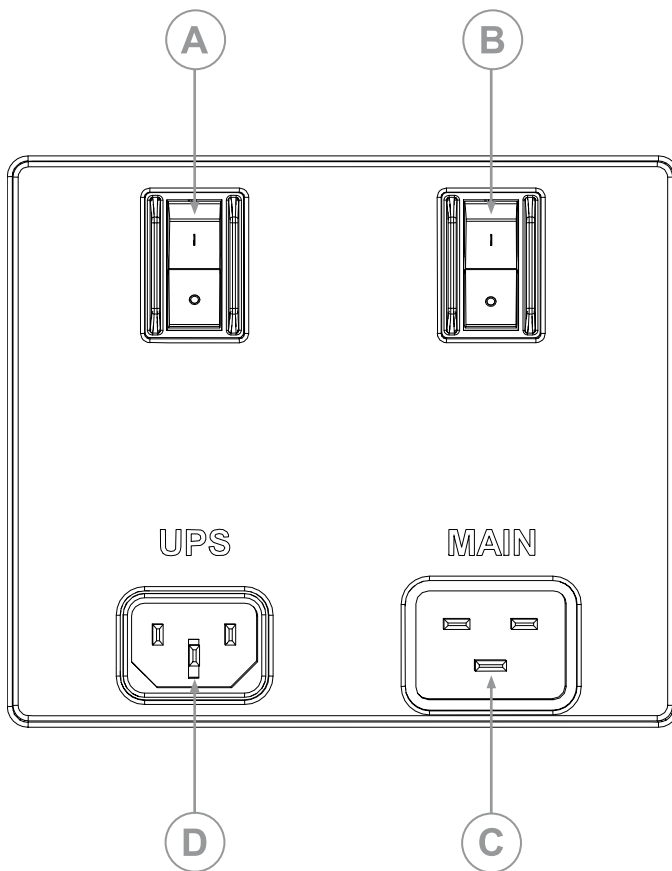

1. Remove the top cover:
  - a) Unlock the cover using the high security key.

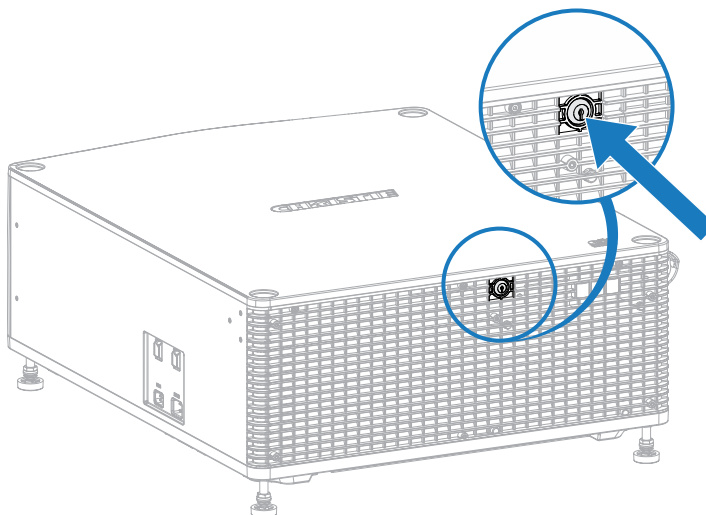

- b) Loosen the five screws (three screws located at the rear of the projector and two screws located at the front of the projector) securing the top cover.

**Three screws located at rear of the projector:**

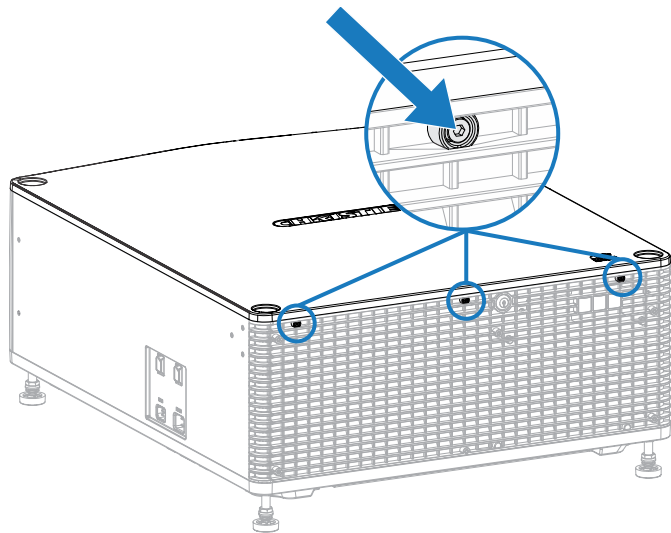

Two screws located at front of the projector:

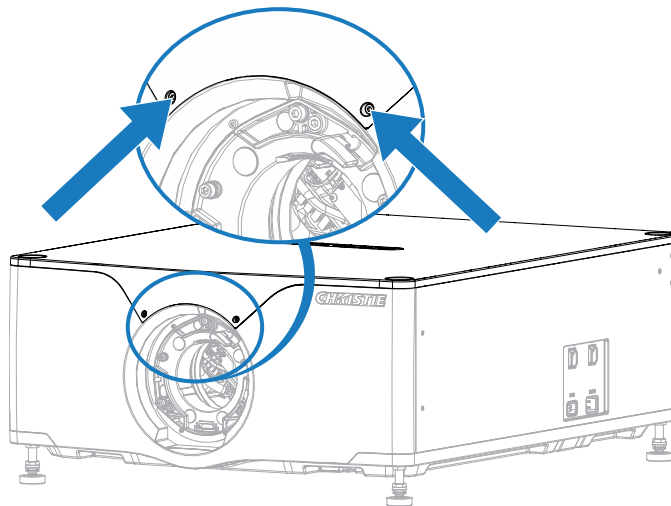

c) Push the cover forward towards the front of the projector.

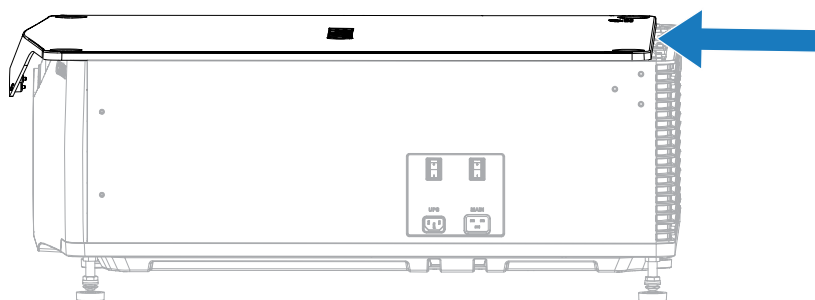

d) Remove the top cover.

2. To access the AC inline connections, loosen the three top screws on the AC insulator shield and move it out of the way.
3. Switch the AC inline connection for 12V power supply from the MAIN inline to the UPS inline.

4. Reattach the AC insulator shield.
5. Replace the top cover.
6. Connect the line cords to the appropriate inputs:
  - One line cord for the MAIN input (C in the Power connections diagram)
  - Another line cord for the UPS input (D in the Power connections diagram)

The right-angle line cords are available for compact spaces and when the AC inputs are configured to route from the front or rear of the unit.

7. To turn on the projector, move the MAIN breaker switch (B in the Power connections diagram) to the ON position and then move the UPS breaker switch (A in the Power connections diagram) to the ON position.

If you do not want to connect to an uninterruptible power supply, connect the 12V AC inline to the MAIN line, connect the appropriate line cord to the MAIN input (C in the Power connections diagram), and only move the MAIN breaker switch (B in the Power connections diagram) to the ON position.

**Related information**

*Turning on or off the projector (on page 42)*

## Installing the lens

The lens seals the projection head, preventing contaminants from entering the main electronics area.



**Warning!** If not avoided, the following could result in death or serious injury.

- Improper installation of the lens can lead to the lens falling out of the projector. Always install the lens as instructed.



**Notice.** If not avoided, the following could result in property damage.

- Do not operate the product without a lens installed.
- Always use a lens plug when installing or moving the product. This prevents contaminants from entering the product.
- Do not insert the lens into the product at an angle. This can damage the lens and the optical components inside the product.
- Always place the lens cap onto the lens when moving the projector to avoid scratching the lens.
- Remove the lens cap before turning on the product to avoid damaging the lens.

1. Before installing the lens, make sure you turn off the projector and the circuit breaker switches.
2. Remove the lens caps from the front and rear of the lens.



Lens caps must be removed or they can melt and damage the lens.

3. Turn the clamp on the lens mount to the open position.

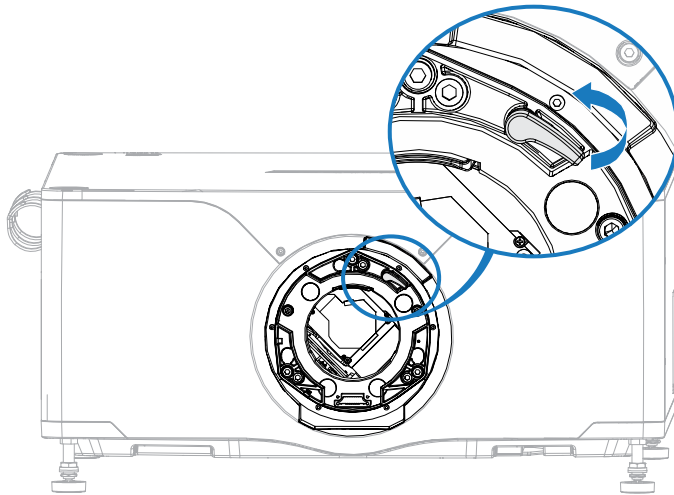

4. Align the lens electrical connector with the mating connector on the lens mount.

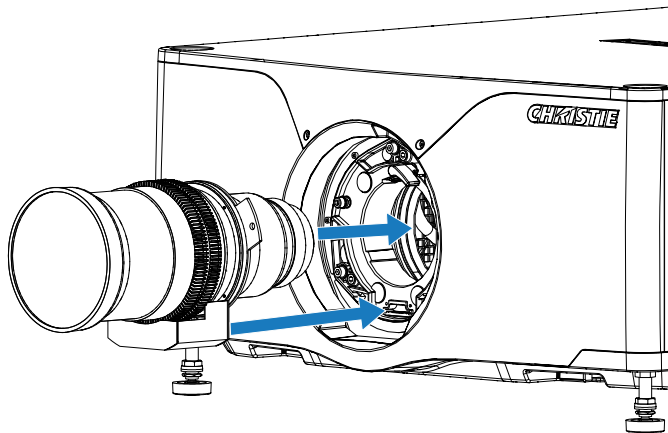

5. Fully insert the lens straight into the lens mount opening without turning it.
6. Mount the lens assembly in place by rotating the lens clamp downward.

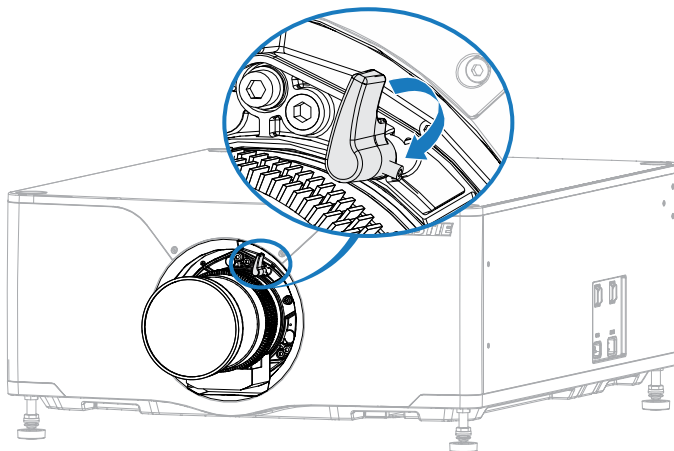

7. Insert and tighten the two lens mount screws (P/N: 012-101028-XX) shipped separately with the projector to at least 30 in-lbs.

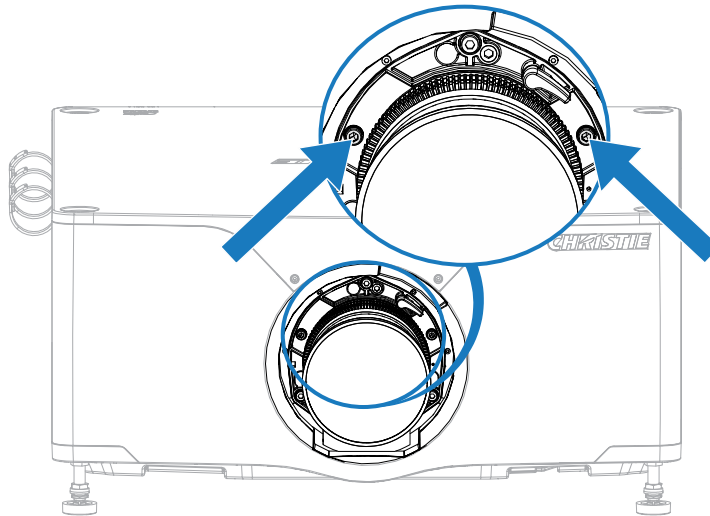

8. Remove the front lens cap.
9. If using an ultra high contrast (UHC) lens, *select the appropriate lens type* (on page 40) in the web user interface.
10. *Calibrate the lens motor* (on page 40) and complete the appropriate *adjusting the image procedures* (on page 55).

## Selecting the lens type

Make sure the appropriate lens type is selected as this impacts the image performance.

1. In the web user interface, in the left navigation menu, select **Service Setup > Preferences > Lens/ILS**.
2. In the Lens Type list, select the lens type.

## Calibrating the lens motor

Make sure the lens motor is calibrated before using the projector.

If the lens motors are not calibrated properly, implications may include:

- Incorrect reporting of the lens motor position.
- Inability to use the full range of the lens motors.
- Lens motors traveling outside of the pre-defined keep-out area.
- Damage to the projector.

Calibrate the lens motors when any of the following conditions are met:

- After a lens change.
- After the projector is moved and/or jostled.
- After any manual adjustment is made to the zoom or focus.

To calibrate the lens:

1. In the left navigation menu, select **Image Settings > ILS File Setup**.
2. Select **Auto Calibrate**.

## Removing the lens

Complete the following procedure to remove the lens.

1. Remove and retain the two security screws (for installation) from the lens mount.

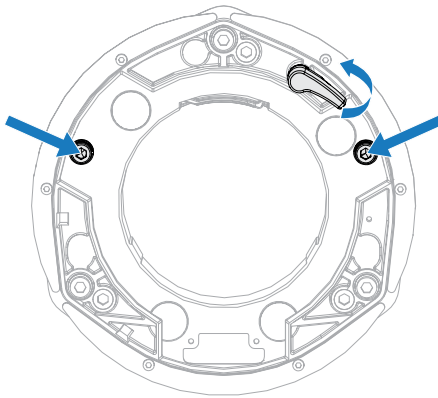

2. Rotate the lens clamp counter-clockwise to the open position.
3. Pull the lens straight out of the lens mount.

## Installing the touch panel

The touch panel controller (TPC) is an optional accessory and is sold separately.

For information on installing the touch panel control (TPC), refer to the *Christie Touch Panel Accessory Instructions (P/N: 020-103409-XX)* instruction sheet.

## Projector power modes

The Cinema 4K-RGBH projectors track laser operation hours for the laser optical subsystem (LOS).

The projector operates with the following power modes:

Mode	Description
Projector on	<ul style="list-style-type: none"> <li>• CineLife+™ electronics and light engine are on</li> <li>• Laser optical subsystem (LOS) is off</li> <li>• Integrated Media Block (IMB) is on</li> </ul>
Light source on	<ul style="list-style-type: none"> <li>• CineLife+™ electronics and light engine are on</li> <li>• LOS is on</li> <li>• Fans run at full speed</li> <li>• IMB is on</li> </ul>
Standby	<ul style="list-style-type: none"> <li>• CineLife+™ electronics remain on standby with the light engine off</li> <li>• Fans and LOS are off</li> <li>• IMB is off—IMB automation does not function</li> </ul>

Mode	Description
Hibernate	<ul style="list-style-type: none"> <li>• Ethernet PHY for Wake On LAN (WOL) magic pocket and Hibernate Interface switch powered and enabled</li> <li>• Other parts of the projector are off</li> </ul>
IMB powered in Standby	<ul style="list-style-type: none"> <li>• Turns on the IMB</li> <li>• Increases the air flow inside the projector to cool the card cage electronics</li> </ul>

## Using the web user interface (Web UI)

Use a web browser to use the web user interface (Web UI) to access projector functionality.



For optimal web user interface viewing, Christie recommends using a screen resolution of 1280 x 800 or higher, preferably with a widescreen aspect ratio such as 16:9 or 16:10.

1. In a web browser, enter the IP address of the projector.  
The default IP address is 192.168.206.110.
2. Log into the Web UI.
3. To access the projector menu, select the left navigation menu.
4. To upload or download files from the projector, navigate to the feature.
5. If the projector has a GDC IMB SR-1000 installed and configured, access the GDC IMB Web UI by navigating to the left navigation menu and selecting **IMB**.

## Turning on or off the projector

Turn on the projector to display content or turn off the projector to conserve energy or service the projector.

1. Determine if you are using an *uninterruptible power supply* (on page 34).
2. Plug the projector into AC power.
3. Turn on the breaker switch(es).
  - If connected to an uninterruptible power supply, move the MAIN breaker switch to the on position and then move the UPS breaker switch to the on position.
  - If not connected to an uninterruptible power supply, only move the MAIN breaker switch to the on position.

4. In the right toolbar, select and hold **Power**. 

If the light source is on when turning off the projector, the light source automatically enters a three-minute cool-down period.

## Logging into the projector

Log into the projector to access projector menus.

1. Select **Login**.

If using the web user interface (Web UI), you do not need to select **Login**.

2. In the User list, select a username.
3. Enter the password.
4. Select **Login**.

## Turning on or off the light source

Turn on the light source to display content or view test patterns. Turn off the light to extend the life of the light source.

- To turn on or off the light source, in the right toolbar, select and hold **Light**. 

If turning on the light source when the projector power is off, power is turned on automatically. Allow the projector to cool down for three minutes after turning it off.

## Checking for the latest software version

Note the version of the software on the projector and check the Christie website to see if a newer version of the software has been released. If a newer version has been released, upgrade the software. For details on updating the software, see the *CineLife+ 2.0 User guide (P/N: 020-103845-XX)*.

Keeping the projector updated with the latest software version ensures access to the latest features and optimal performance abilities.

## Activating marriage

After selecting the Integrated Media Block (IMB) type, you must install the IMB and complete marriage to display secure content and to comply with the Digital Cinema Initiatives (DCI) specification. You cannot complete marriage remotely.

For more information on installing the IMB, see the appropriate IMB installation documentation.

For more information on marriage, see *CineLife+ 2.0 User guide (P/N: 020-103845-XX)*.

You cannot complete marriage remotely because you must select the **Marriage** button on the input panel during the marriage process.

1. Verify the marriage ring is installed correctly and an anti-tamper alarm does not appear on the touch panel.
2. In the left navigation menu, select **Service Setup > Marriage Setup**.
3. Select **Start** and complete the Marriage Setup wizard.  
At the Arming stage, enter the Marriage password.
4. Select **Finish**.

## Disposing of the product packaging

Once the product has been installed and set up, Christie recommends reusing or recycling the product packaging according to your local regulations.

## Completing the installation checklist

Complete the provided installation checklist (P/N: 020-103137-XX) and return it to Christie.

# Video Input panel

The Video Input panel, located on the projector side input panel (operator side), has a variety of ports that can supply alternative video content to the projector.

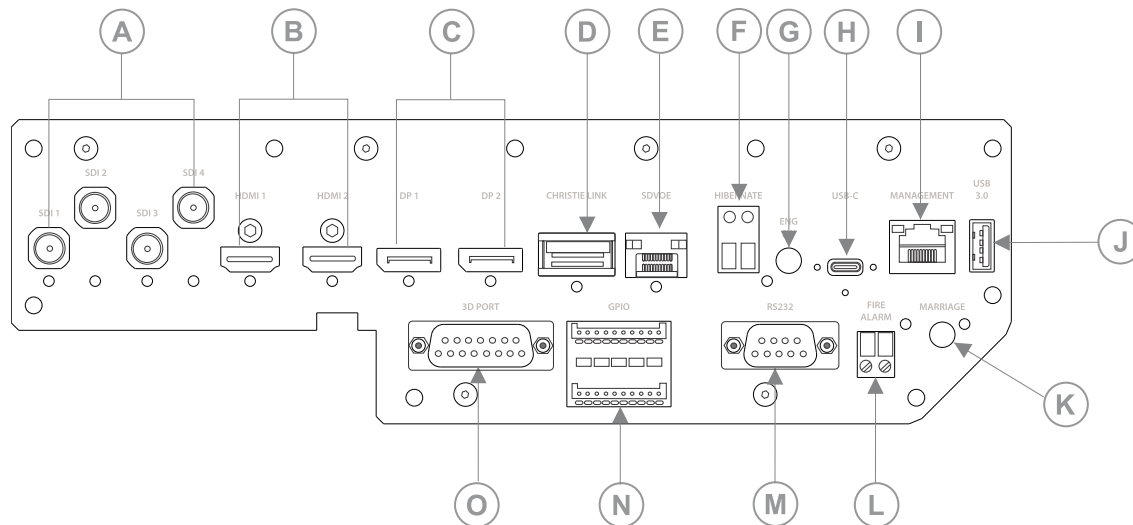

ID	Port	Description
A	SDI input 1, SDI input 2, SDI input 3, and SDI input 4	75 ohm BNC Connector Multi-Rate SDI in accordance with SMPTE ST 259 (270 Mb/s), ST 292-1 (1.5 Gb/s), ST 424 (3.0 Gb/s), ST 2081-1 (6 Gb/s) and ST 2082-1 (12 Gb/s)
B	HDMI input 1 and HDMI input 2	Type A connector Accepts digital video data from HDMI v2.0 input supporting EDID 1.3 with HDCP v1.4 and 2.2 support.
C	DisplayPort (DP1 and DP2)	Full size DisplayPort connector Accepts digital video data from DisplayPort 1.2 input supporting EDID 1.3 with HDCP 1.3 support.
D	Christie Link port	Not used.
E	Software-Defined Video over Ethernet (SDVoE) port	Not used.
F	Hibernate	Two-wire terminal block to permit the user to connect a contact switch to bring the projector out of hibernate mode.
G	ENG SW	Select the button to transition the projector from Standby mode to Power ON mode or bring the projector out of hibernate mode.
H	USB-C port	Connects the projector touch panel.

ID	Port	Description
I	Management port	Connects to the local network and can send CineLife+™ serial commands and used for Web UI access.
J	USB 3.0	Connects to external memory device for import and export of projector software, configuration files, and status information.
K	Marriage button	Used during the Integrated Media Block (IMB) marriage setup process. <ul style="list-style-type: none"> <li>• Select and hold the button for 5 seconds to display the IP address and status information.</li> <li>• Select and hold the button for 30 seconds to reset the IP address to the default address.</li> </ul> The marriage status LED indicator is located to the right of the Marriage button. In full power mode, a green LED indicates the projector is properly married and encrypted content can be displayed. A red LED indicates marriage is broken and encrypted content cannot be displayed.
L	Fire alarm connection	Connects to the Theater Fire Management system for automatic shut down in emergency situations.
M	RS232 communication port	Not used.
N	GPIO port	Connects the projector to external automation or automation devices.
O	3D sync connector	15-pin Subminiature D-Type, Female Proprietary 3D communication protocol with combined RS 232-C and GPIO communication. Used for controlling external active and passive 3D polarization systems and glasses.

## HDMI video source

For the projector to accept digital video data from HDMI sources, plug the HDMI source directly into the Video Input panel.

The input configurations listed below are supported.

Input configuration	Description
Single-input	Accepts connection of one HDMI cable. Supports both 2D and 3D frame-packed, top and bottom. In this configuration, the HDMI input supplies the entire video raster.
Dual-input	Enables connection of two HDMI cables in support of 3D LR, where HDMI Input 1 = left eye and HDMI Input 2 = right eye.

For supported video formats for your projector model, see *CineLife+ Supported Video Formats technical reference (P/N: 020-104085-XX)*.

## SDI video source

For the projector to accept digital video data from 12G, 6G, 3G, or HD/SD SDI video source, plug the source directly into the Video Input panel.

The input configurations listed below are supported.

Input configuration	Description
Single-link	Accepts connection of 12G, 6G, 3G, and HD/SD SDI input standards.
Dual-link	Accepts connection of dual-link 6G, 3G, and HD SDI input standards.
Quad-link	Accepts connection of quad-link (2SI) 6G or 3G SDI input standards. Accepts connection of quad-link (SQ div) 6G, 3G, or 1.5G SDI input standards.

For supported video formats for your projector model, see *CineLife+ Supported Video Formats technical reference (P/N: 020-104085-XX)*.

## DisplayPort video source

For the projector to accept digital video data, plug the DisplayPort source directly into the Video Input panel.

The input configurations listed below are supported.

Input configuration	Description
Single-input	Enables connection of one DisplayPort cable. Supports both 2D and 3D frame sequential transmission format. In this configuration the DisplayPort input supplies the entire video raster.
Dual-input	Enables connection of two DisplayPort cables. Supports both 2D and 3D frame sequential transmission format.

For supported video formats for your projector model, see *CineLife+ Supported Video Formats technical reference (P/N: 020-104085-XX)*.

## Integrated Media Block (IMB) video source

Christie Series 4 projectors support both the legacy Series 2 (S2) and newer Series 4 (S4) HDRConnect™ IMB interfaces to send digital video data from an IMB to the projector.

Contact Christie Technical Support to learn which S2 and S4 IMB devices are compatible with Christie projectors.

For supported video formats for your projector model, see *CineLife+ Supported Video Formats technical reference (P/N: 020-104085-XX)*.

## HDMI video source connection from an Integrated Media Block (IMB)

The projector can accept digital video data from HDMI sources connected to applicable Integrated Media Block (IMB) devices. The input configurations supported are determined by the IMB device directly.

Contact Christie Technical Support to learn which IMB devices provide HDMI source selection from the projector user interface.

HDMI input selection directly from the IMB may also be possible using the IMB user interface. The input configurations supported are determined by the IMB make and model.

## SDI video source connection from an Integrated Media Block (IMB)

The projector can accept digital video data from SDI sources connected to applicable Integrated Media Block (IMB) devices.

The input configurations supported are determined by the IMB device directly. Contact Christie Technical Support to learn which IMB devices provide SDI source selection from the projector user interface.

SDI input selection directly from the IMB may also be possible using the IMB user interface. The input configurations supported are determined by the IMB make and model.

## GPIO connector

The Generic Purpose Input Output (GPIO) connector provides a flexible method of interfacing with the projector. 18 GPIO pins are available on the GPIO connector. Two other pins are reserved for ground and power.

The GPIO connector is located on the input panel.

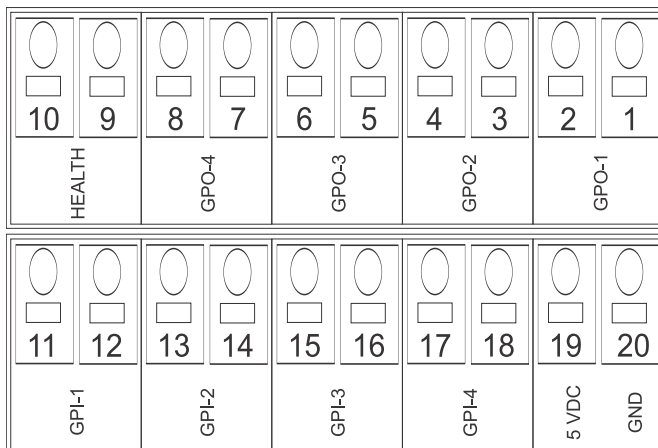

Pin number	Signal name	Direction
Pin 1	GPO1_POS	Out
Pin 2	GPO1_NEG	Out

Pin number	Signal name	Direction
Pin 3	GPO2_POS	Out
Pin 4	GPO2_NEG	Out
Pin 5	GPO3_POS	Out
Pin 6	GPO3_NEG	Out
Pin 7	GPO4_POS	Out
Pin 8	GPO4_NEG	Out
Pin 9	HEALTH_POS	Out
Pin 10	HEALTH_NEG	Out
Pin 11	GPI1_POS	In
Pin 12	GPI1_NEG	In
Pin 13	GPI2_POS	In
Pin 14	GPI2_NEG	In
Pin 15	GPI3_POS	In
Pin 16	GPI3_NEG	In
Pin 17	GPI4_POS	In
Pin 18	GPI4_NEG	In
Pin 19	+5V	—
Pin 20	GND	—

### GPIO inputs

The 5 VDC (pin 19 and pin 20) is intended for use to supply the inputs.

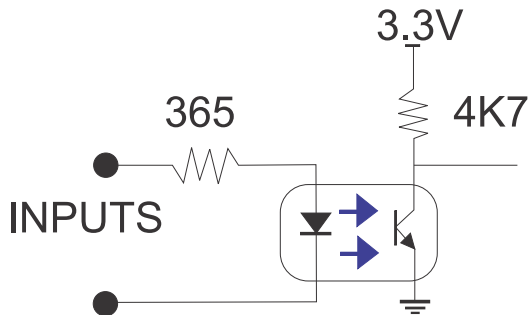

### GPIO outputs

Outputs are solid state relays with a 1 A AC/DC rating at up to 48 V.

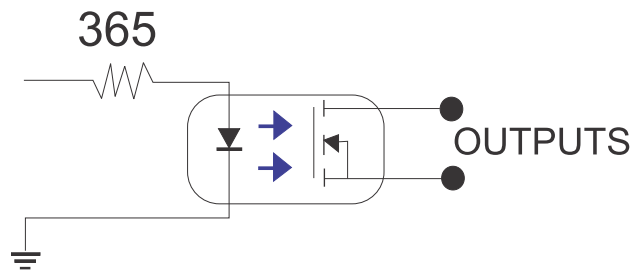

# Managing the light source

Learn how to configure a laser file and use the projector's LiteLOC™ feature.

Use the laser file to control the power settings of the lasers. The LiteLOC™ feature ensures that color and brightness are held at the level you set.

Create multiple laser files to manage varying screen sizes, brightness requirements, and types of content (such as 2D, 3D, and alternative content).

## Creating a new laser file

Create a laser file to store the power settings for the laser light source and the maximum expected room temperature for the projection booth.

To make sure color and brightness are held at the required levels for your installation, enable LiteLOC™ for each laser file you create. If you make significant change to the brightness level when refining the laser power settings, it takes a few minutes for the color and brightness to stabilize.

1. Log in as service.
2. Turn on the laser.
3. Set a channel to use the appropriate calibration file and activate the channel.  
For details on setting up and activating the channel, refer to the *CineLife+ 2.0 User guide* (P/N: 020-103845-XX).
4. Display a test pattern, such as DC4K 17 L Point, to locate the center of the screen.
5. Set up the color meter to aim at the center of the screen.
6. In the left navigation menu, select **Laser Settings > Laser Power/LiteLOC Setup**.
7. Select **Display White Test Pattern**.
8. To create a new laser file, select **Create**. 
9. In the Create dialog, enter a name for the new laser file and select **Create**.
10. Adjust the brightness level until you achieve the required brightness at the specified white point.
11. If the laser file will be associated with a 3D channel, complete the following steps:
  - a) Engage the 3D system in the light path by enabling **3D Sync** when selecting the test pattern.
  - b) Mount a 3D glass or filter on the color meter to measure the brightness.
  - c) Select **3D Sync** on the LiteLOC™ setup page.
  - d) Adjust the brightness level until you achieve the required brightness while the 3D system is engaged.

12. To save the new laser file, select **Save**. 

## Modifying an existing laser file

Modify the settings in the laser file to change the laser power settings or the maximum expected room temperature.

When refining the laser power settings, the amount of time required to re-stabilize the projector depends on the size of the adjustment. For small adjustments to the expected room temperature or power settings, the projector requires only 1 or 2 minutes to re-stabilize. For larger adjustments, the projector may require up to 15 minutes to re-stabilize.

1. In the left navigation pane, select **Laser Settings > Laser Power/LiteLOC Setup**.
2. From the Laser File list, select the laser file to edit.
3. Select the **Display White Test Pattern**, if required.
4. Adjust the brightness slider as required.
5. Once the correct brightness is achieved and the projector has stabilized, to save the new settings select **Save** .

## Copying existing laser settings to a new file

Copy an existing laser file when you want to create a new file with similar settings.

1. In the left navigation pane, select **Laser Settings > Laser Power/LiteLOC Setup**.
2. From the Laser File list, select the file you want to copy.
3. To save the new laser file, select **Save As** .
4. Enter a new name for the laser file and select **Save**.
5. Adjust the brightness and white settings as required for the new configuration.

## Deleting a laser file

Delete a laser file when the configuration is no longer required.

1. In the left navigation menu, select **Laser Settings > Laser Power/LiteLOC Setup**.
2. In the Laser File list, select the file to delete.
3. Select **Delete** .
4. To confirm the deletion, select **Delete**.

## LiteLOC™ sensor-to-screen calibration

The LiteLOC™ sensor-to-screen calibration is performed in the factory under specific setup conditions which include the type of lens, screen, and the spectroradiometer used for measuring screen color and brightness.

Your projector's setup conditions may not match the factory setup which may result in a discrepancy in color accuracy. Upon first installation, check the accuracy of the color point and if unsatisfactory, perform this calibration using Hawkeye. Doing this calibration captures all the variables of your setup and achieves the best results. By doing this calibration, you do not overwrite the factory calibration. Once satisfied, some scenarios may exist in which you may need to redo the calibration in the future.

Redoing this calibration is required if the following is replaced:

- Color sensor board

Christie recommends redoing this calibration if any of the following are replaced:

- Light engine
- Lens
- Light source
- Screen
- Port window
- Any other optical components in the optical path between the light source and the screen

After replacing these components, check the accuracy of the color point and if unsatisfactory, redo this calibration.

## Running a Hawkeye calibration

Learn how to perform a LiteLOC™ calibration using Hawkeye.

1. If required, contact your Christie representative for the Hawkeye software.
2. Open the Hawkeye software.  
A laptop or PC is required to run the Hawkeye software.
3. Make sure the projector subnet and computer subnet match.
4. Connect the spectroradiometer with the Hawkeye software.
5. Aim the spectroradiometer toward the center of the image.
6. Run Hawkeye calibration.

Make sure the process is done in low light and is not interrupted. The process lasts approximately 50 minutes.

## Adding a calibration file to the Channel Setup

Select any of the available calibration files stored on the projector system by accessing the 2D Sensor-to-Screen Calibration File or 3D Sensor-to-Screen Calibration File list in the Channel Setup menu.

By default, the 2D and 3D sensor-to-screen calibration files are set to the factory or field calibration data identified as Default in the list. The Default selection references the factory calibration data as long as no field calibration data is available. If field calibration data is available, it is selected as the Default. When a 2D and 3D Sensor-to-screen Calibration file is selected in the Channel Setup, the

active channel automatically applies the calibration data according to the 2D or 3D operation of the projector.

1. In the left navigation menu, select **Channel Setup**.
2. Select the channel you want to add the calibration file to.
3. From either the **2D Sensor-to-Screen Calibration File** or **3D Sensor-to-Screen Calibration File** list, select the calibration file.
4. Select **Save**.

# Adjusting the image

Learn how to adjust image geometry so it displays correctly.

## Calibrating the Intelligent Lens System

On Cinema 4K-RGBH projectors, the Intelligent Lens System (ILS) is activated by default.

Use the Auto Calibrate feature of the ILS to find and compensate for motor backlash, and to determine the movement range for the currently installed lens.

1. In the left navigation menu, select **Image Settings > ILS File Setup**.
2. From the ILS File list, select an available ILS file.
3. Select **Auto Calibrate**.
4. Select **Continue**.  
The system performs the lens calibration.

## Correcting vignetting

An image that is brighter at the center than it is at the sides needs vignetting correction.

If your image suffers from vignetting, the lens has reached the end of its offset travel range.

If your installation does not allow the image to be centered with the center of the screen, move the entire projector in the direction of lens travel.

## Adjusting tilt and leveling the projector

To ensure optimum performance, install the projector so it is centered and parallel with the screen.

To compensate for tilt or offset, you can adjust the projector feet and the lens mount position.



The front-to-back tilt of the projector must not exceed 15° in a downward direction or 5° in an upward direction. The side-to-side tilt must be within +3° to -3° of level.

1. To adjust the height of the projector, loosen the lock nut on the adjustable feet on the bottom of the projector.

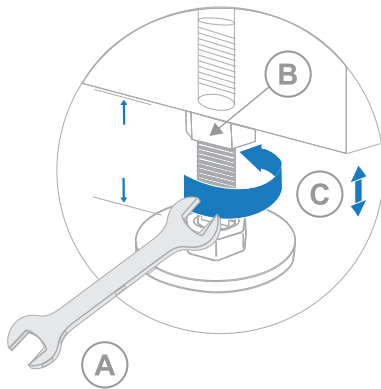

A	Adjustable wrench
B	Lock
C	Turn to adjust height

2. Extend or retract the feet.
3. When adjusting projector angles, confirm opposing feet are adjusted in equal amounts within 4 mm mismatch by measuring each foot extension height.  
Top cover misalignment is an indicator of unequal foot extension.
4. When the adjustment is correct, tighten the lock nut.

## Correcting keystone effect

Keystone effect occurs when you project an image onto the screen at an angle. As a result, the image appears distorted and resembles a trapezoid.



When making the adjustments, set the light source to minimum power.

Horizontal keystone	Vertical keystone
Projector skewed horizontally to the screen	Projector tilted vertically to the screen

1. If the image suffers from slight keystone effect, it can be corrected with electronic cropping.
2. If the keystone effect is severe, unevenly adjust the feet to compensate for projector tilt.  
Christie recommends using the lens offset to align the center of the image to the center of the screen before correcting the keystone effect.
3. If one side of the image is longer than another, adjust the tilt and level of the projector.

## Displaying a test pattern

Display a test pattern to refine and adjust the projected image or to diagnose and correct image issues.

1. In the right toolbar, select **Test Patterns**. 
2. Select **Full Screen**.
3. Select a test pattern.  
When a test pattern is active, a blue bar appears below the test pattern icon in the right pane.
4. To display a 2D test pattern in 3D mode, select the **3D Sync** option.  
The **3D Sync** option is selected automatically for 3D test patterns. 3D test patterns cannot be displayed in 2D mode.
5. To change the frame rate of the test pattern display, select from the available Frame Rate options:
  - For 2D test patterns, the available frame rates are 24, 30, 48, and 60 Frames Per Second (FPS). The default value is 24 FPS.
  - For 3D test patterns, the available frame rates are 24 FPS (per eye) and 30 FPS (per eye). The default value is 24 FPS (per eye).

Changing the frame rate of the display can assist with color measurement when working with corrected colors.

When changing the frame rate option, the option is applied to the next test pattern you select unless it is not available for that pattern. If a selected frame rate is not available, the default frame rate is applied for the test pattern display.

## Adjusting the integrator rod focus and fold mirror

Understand how to adjust the integrator rod focus and fold mirror to control the illumination spot on the digital micromirror device (DMD).

Extreme misalignment of projection optics can cause permanent damage to critical optical components. Only Christie qualified technicians can perform internal optical adjustments.

The integrator rod focus and fold mirror adjustments are set by Christie. Make adjustments only if screen shadows are visible.



When adjusting the fold mirror, set the light source to minimum power.

1. Set the laser power to 30% or less.  
High power and misalignment can damage the DMDs.

2. In the right toolbar, select **Test Patterns**. 
3. Select the **RGB-4K-Integrator Rod** test pattern and display it full screen.

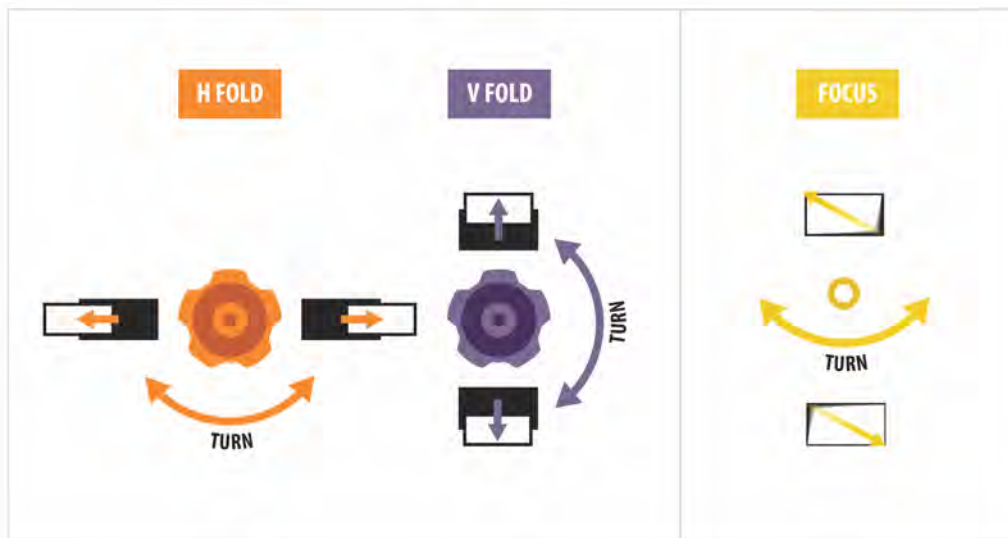

Refer to the test pattern for guidance on making the adjustments. The left panel provides information about the fold mirror adjustments. The right panel of the test pattern provides information about the focus adjustments.

4. To use the integrator rod optical controls, remove the top cover:
  - a) Unlock the cover using the high security key.

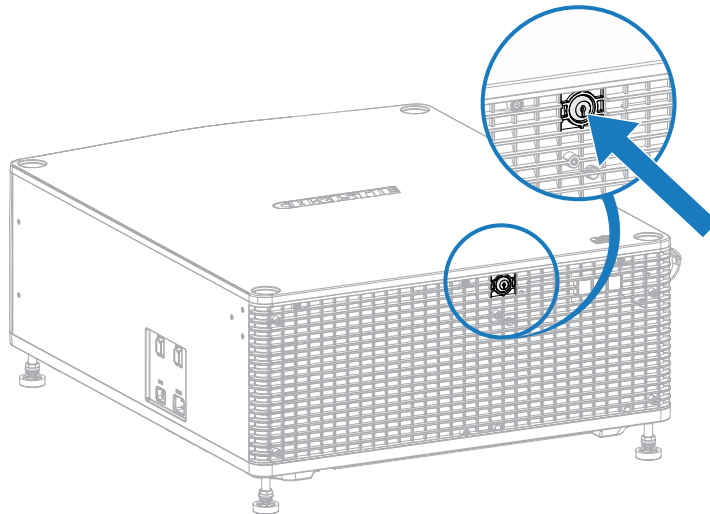

- b) Loosen the five screws (three screws located at the rear of the projector and two screws located at the front of the projector) securing the top cover.

**Three screws located at rear of the projector:**

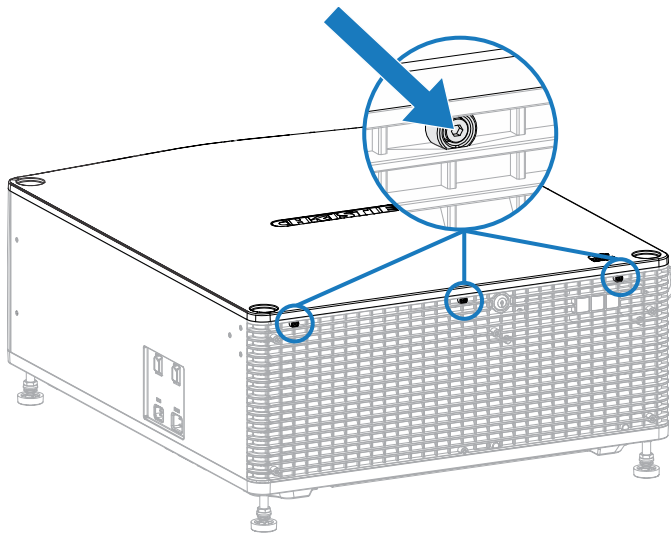

Two screws located at front of the projector:

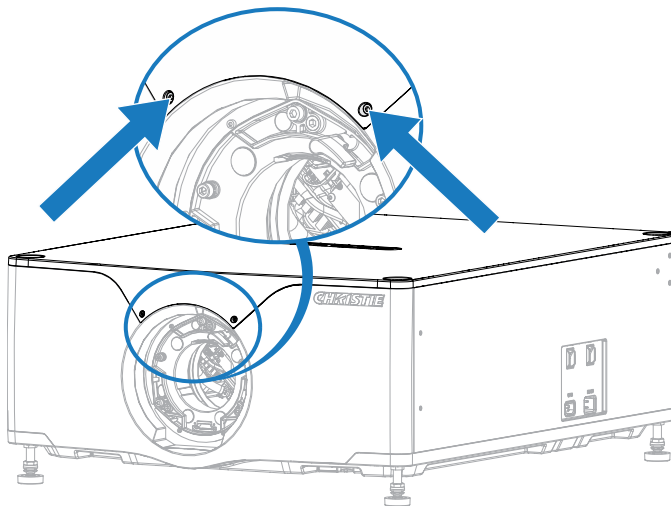

c) Push the cover forward towards the front of the projector.

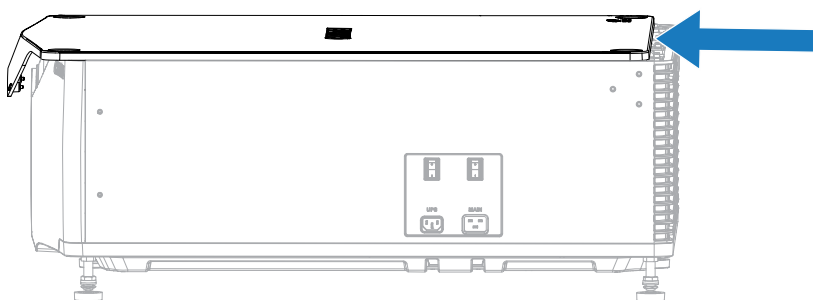

d) Remove the cover.

5. Loosen the fold mirror screws to unlock the fold mirror adjustment knobs.

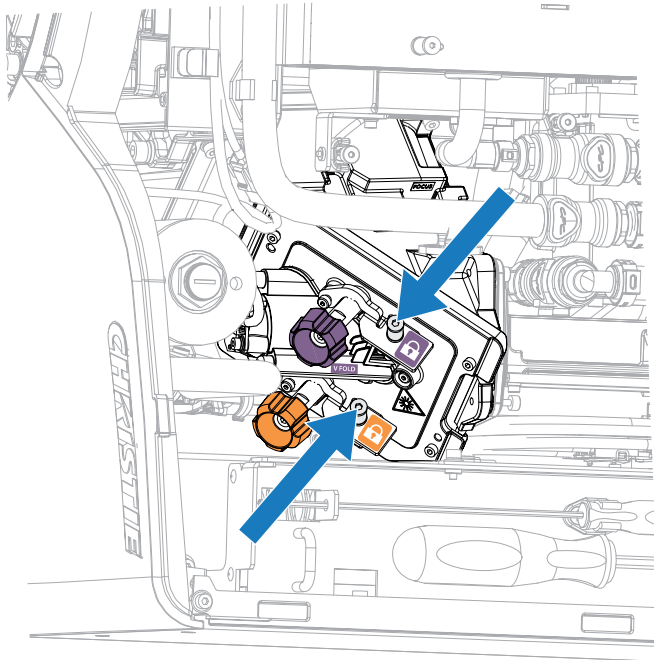

6. To make horizontal adjustments on the fold mirror, use the orange adjustment knob. To make vertical adjustments on the fold mirror, use the purple adjustment knob.

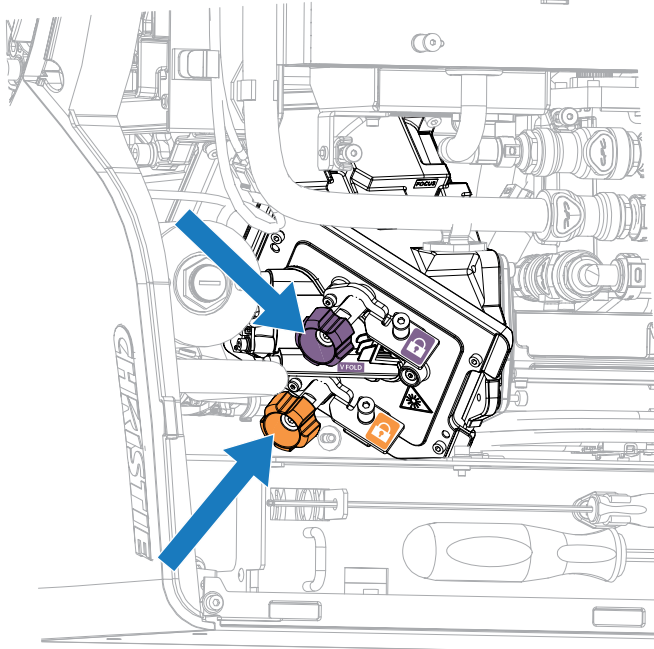

7. Adjust the fold mirror until either the top left edge or the bottom right edge of the illumination spot becomes visible on the DMD.
8. Adjust the integrator rod focus screw to optimize focus for one of the following:
  - Along the top edge of the image, approximately one-third across the image from the left.

- Along the bottom edge of the image, approximately one-third across the image from the right.

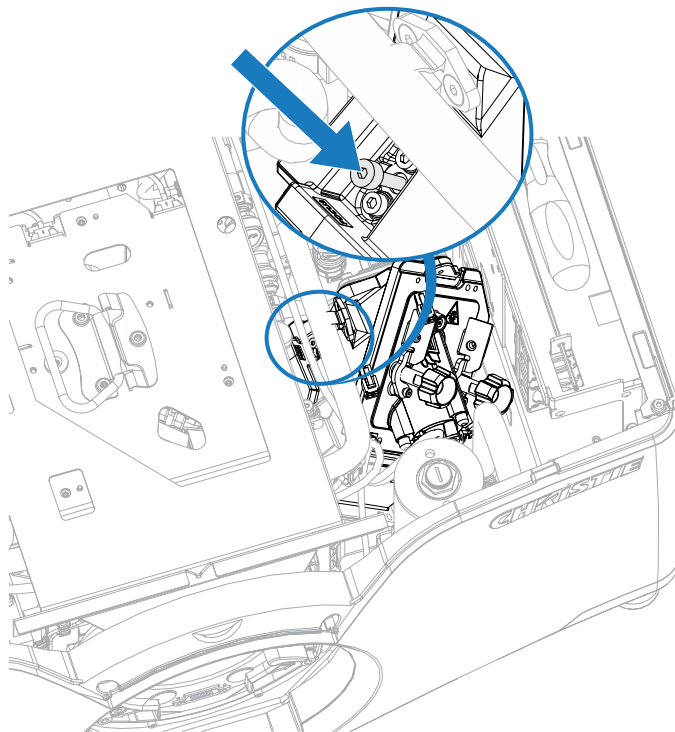

9. Adjust the fold mirror to center the image on the DMD array.
10. Once the adjustments are complete, tighten the lock screws for the two fold mirror screws.

## Aligning the boresight

The boresight adjustment balances the tilt of the lens mount to compensate for screen-to-projector tilt.



**Caution!** If not avoided, the following could result in minor or moderate injury.

- Do not look directly into the lens when the light source is on. The extreme high brightness can cause permanent eye damage.



If doing excessive boresight adjustment, it may make the lens keep-out zones smaller.

1. Display the boresight test pattern.
  - a) In the right toolbar, select **Test Patterns**. 
  - b) Select the **RGB-4K-Boresight** pattern and display it full screen.

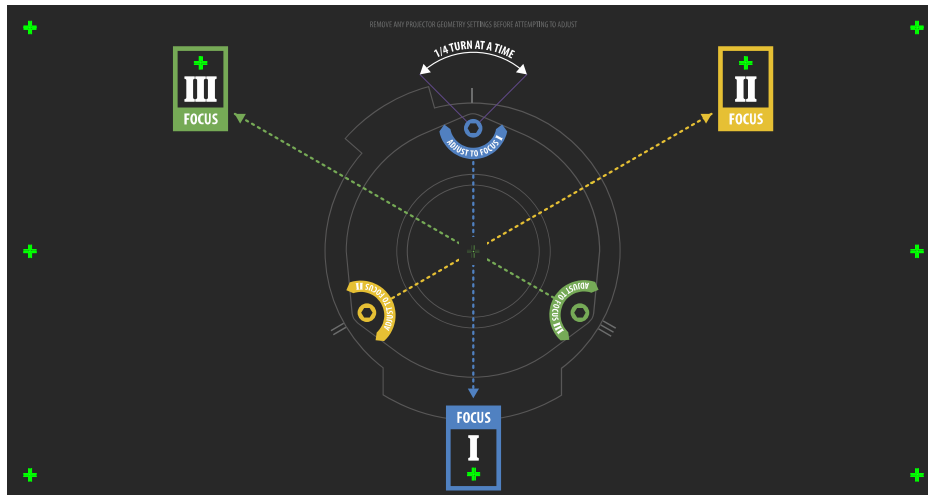

2. Focus the image on cross-hair image **I**.
3. Evaluate the focus on cross-hair image **II** and **III**.
  - If all three images are in focus, no further action is required.
  - If boresight is required, continue to step 4.

The adjustment screws (A) on the lens mount affects the corresponding cross-hairs on the test pattern.

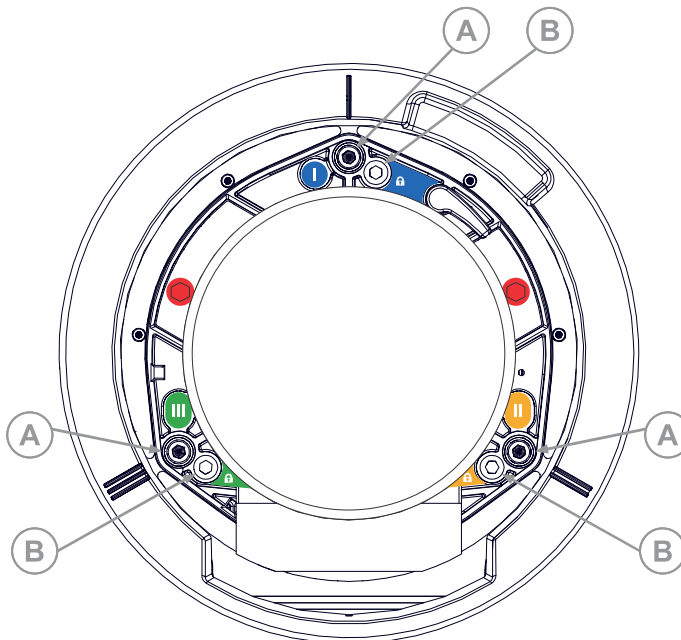

4. To loosen the three setscrews (B) on the lens mount, use a 5 mm hex driver. The setscrews must be backed out several turns to avoid contact with the inner lens mount plate.
5. To fine tune the focus of cross-hair pattern **I**, adjust the appropriate adjustment screw (A) until the cross-hair image is in focus with minimal flare.

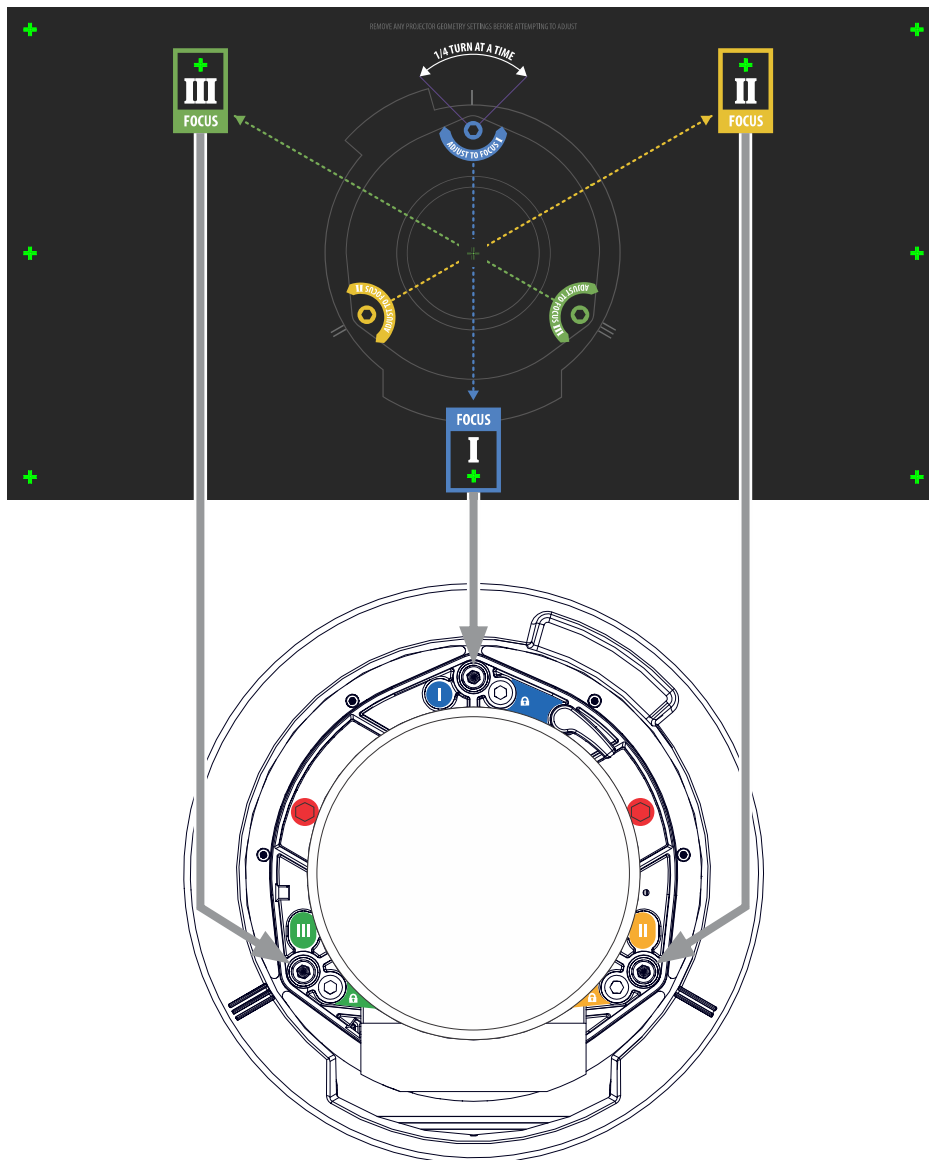

6. To fine tune cross-hair pattern **II**, adjust the appropriate adjustment screw until the cross-hair image is in focus with minimal flare.
7. To fine tune cross-hair pattern **III**, adjust the appropriate adjustment screw until the cross-hair image is in focus with minimal flare.
8. Repeat step 5 to 7 as required until all three cross-hair patterns are in equal sharp focus.
  - If the boresight is acceptable, proceed with step 11.
  - If the boresight does not appear to be converging to an acceptable level of image quality, or if the lens does not focus over the correct range of throw distances, proceed with step 9.
9. To approximately recover the original factory boresight, position the three setscrews flush with the front face of the lens mount plate and in contact with the inner lens mount plate. This may require adjusting both setscrews and adjustment screws.

10. If further action is required, repeat steps 2 to 9.
11. Lock the setscrews, and re-check the boresight quality.  
Tighten the setscrews to 2.1 Nm (18 in-lb) to make sure they do not shift.

## Correcting on-screen color

After installation, further image adjustments may be required to correct color on the screen.

The next steps may include creating a Measured Color Gamut Data (MCDG) file and configuring a Pureformity Color™ Technology (PCT) file to achieve optimal color and brightness uniformity.

For more information on managing color settings, see the *CineLife+ 2.0 User guide (P/N: 020-103845-XX)*.

## Electronic Color Convergence (ECC)

A lateral convergence error occurs when the red, green, and blue (RGB) primary colors are not converged through projected lenses and is most noticeable at the edges of the screen. To address this, use ECC.

Electronic Color Convergence (ECC) is accomplished by aligning a red, green, and blue sprite, which is displayed at the four corners of the displayed image. For electronic convergence all three colors can be adjusted.

Always align the color components of the sprite to the inner most line color (for each axis). When converged, the three colors should overlap to form white lines. Applying the sprite alignment settings to the screen results in the three colors overlapping to form white lines throughout the image.

One or more poorly converged individual colors may appear adjacent to some or all of the lines.

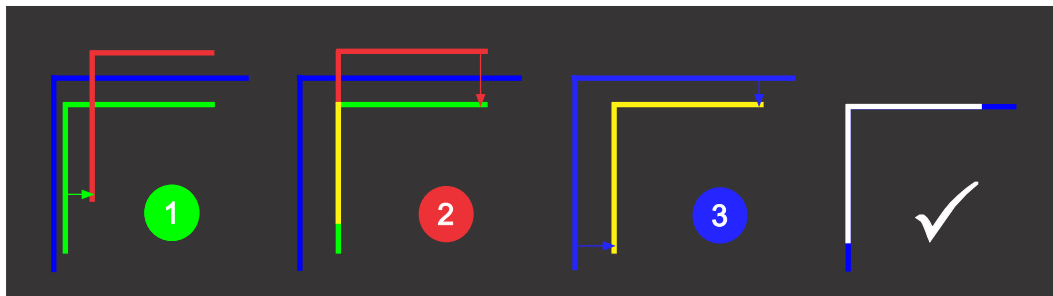

If you wear glasses with corrective lenses when performing this adjustment, make sure you are viewing the test pattern on a straight angle through the optical axis of your glasses and not from a tilted or angled perspective. This avoids a prismatic effect that can appear to shift convergence when viewing at an angle.

## Mechanically adjusting digital micromirror device (DMD) convergence

Use the convergence adjustment screws located in the light engine assembly to mechanically adjust convergence.

1. Before adjusting digital micromirror device (DMD) convergence, make sure the projector has reached a steady operational state.

If switching from a white or bright test pattern to a dark convergence test pattern or if warming up the projector after a shutdown, allow 15 minutes for stabilization so the optics can reach a steady state.

2. Make sure the electronic color convergence (ECC) is defaulted before doing mechanical convergence.
3. In the right toolbar, select **Test Patterns**. 
4. Select the **RGB-4K-Convergence** test pattern and display it full screen.



5. Select the following options:
  - Uncorrected Colors
  - Uncorrected Geometry
6. Remove the top cover of the projector:
  - a) Unlock the cover using the high security key.

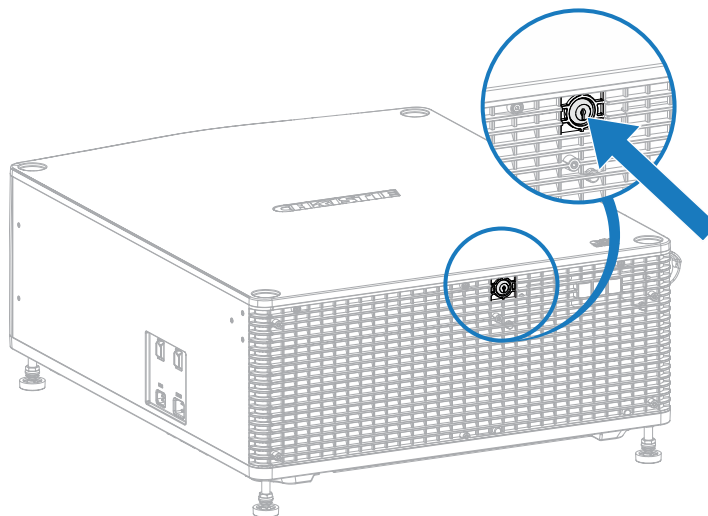

- b) Loosen the five screws (three screws located at the rear of the projector and two screws located at the front of the projector) securing the top cover.

Three screws located at rear of the projector:

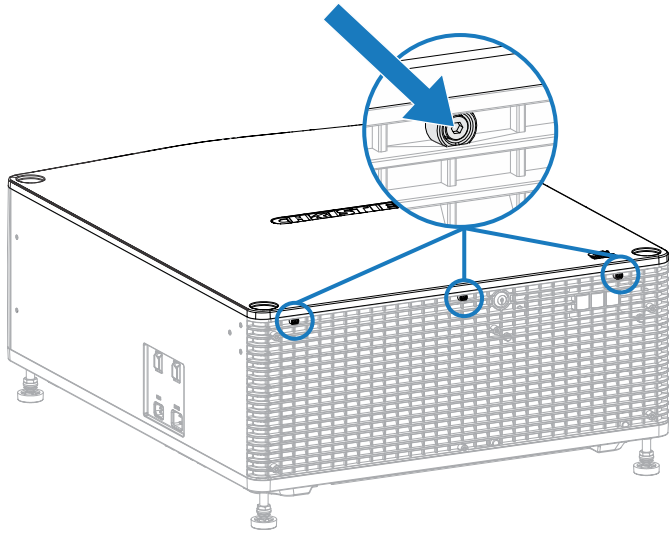

Two screws located at front of the projector:

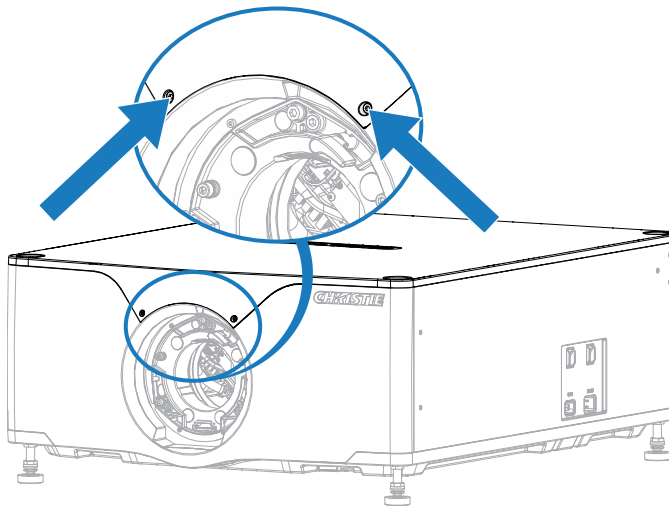

c) Push the cover forward towards the front of the projector.

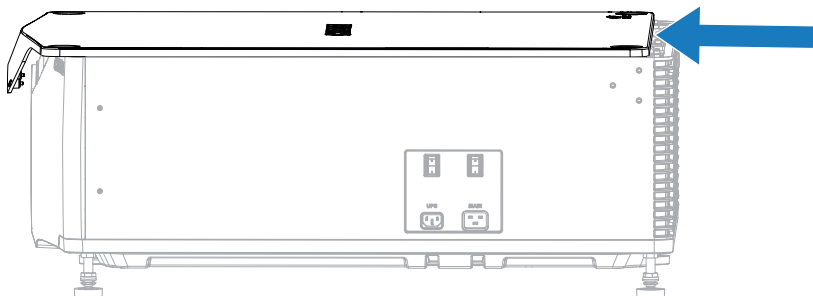

d) Remove the cover.

7. To adjust the convergence adjustment screws, use the 2.5 mm driver included with the projector.

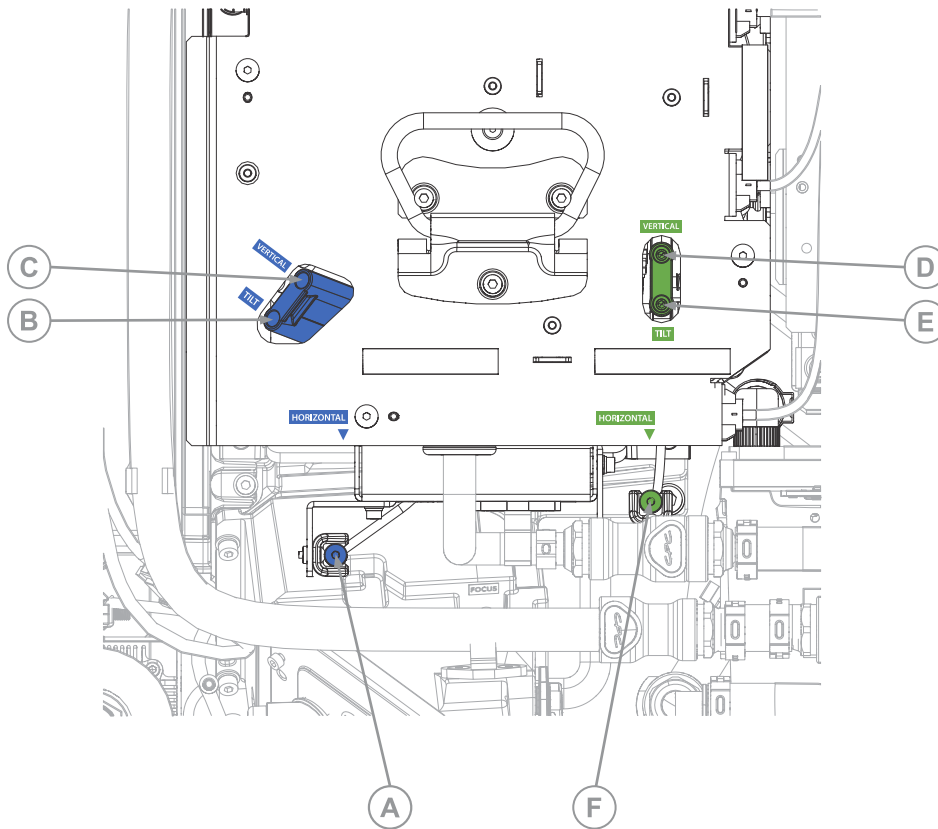

A	Blue horizontal
B	Blue tilt
C	Blue vertical
D	Green vertical
E	Green tilt
F	Green horizontal

8. Use the Convergence test pattern to assist with adjusting the tilt, horizontal, and vertical lines.
  - Tilt adjustments are controlled by adjusting screws B or E.
  - Horizontal adjustments are controlled by adjusting screws A or F.
  - Vertical adjustments are controlled by adjusting screws C or D.



Adjust tilt first so the right and left sides are even (use the red scales on either side), then proceed with the horizontal and vertical adjustments.

9. If the colors at the corners of the screen require further correction, see *Electronically adjusting convergence* (on page 68).

## Electronically adjusting convergence

Use the electronic convergence feature in the menu to adjust convergence. Only perform electronic convergence when satisfied with the position of the image on the screen.

1. In the left navigation menu, select **Image Settings > ILS File Setup**.
2. Select an ILS file to store the ECC settings.
3. On the ILS File Setup page, select **ECC**.  
Each corner of the screen displays three separate sprites, one for each primary color. The user interface displays the Test Pattern controls.
4. Set the Screen Type to **Flat** or **Scope**.  
This sets the test pattern and the location of the sprites on the screen. Each sprite appears as the letter L.
5. Set the Sprite Color to **Move** and **Show**.  
When first opening the ECC, all Show and all Move colors are selected, so all three sprites are displayed and all three sprites are moved by the directional pad.
6. Select a **Step Size** to control the granularity of the steps from coarse (1/8 pixel per step) to fine (1/64 pixel per step) when using the directional pad.  
Sprites can be moved a maximum of 20 pixels.
7. Choose a corner by selecting the circle at a corner of the dashed rectangle.  
The selected corner is indicated by a green circle. The X/Y pixel offset (from no correction) displays in red, green, and blue text corresponding to each sprite.
8. Use the directional pad to move the sprites towards the center of the screen.
9. Adjust each sprite so they overlap to create a single white sprite.  
In the example below, the red sprite (in image 1 below) was moved down and the blue sprite (in image 1 below) was moved to the right so they overlap to create the single white sprite (image 2 below).

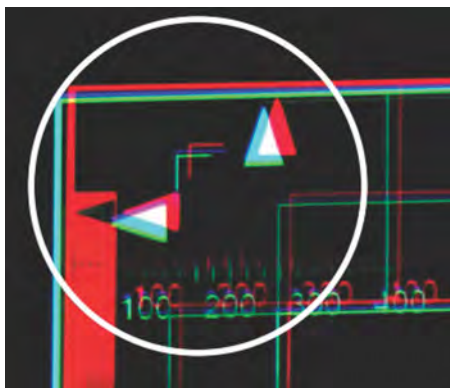

1

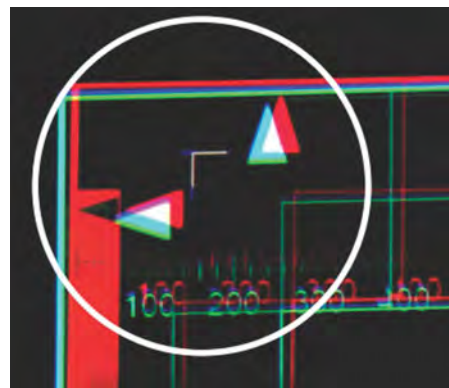

2

10. To set the convergence for that corner of the screen, select **Apply**.



11. Repeat steps 7 to 10 for the remaining corners.
12. If necessary, reset the correction back to zero (no correction) or the previously saved correction by selecting **Reset**.  
In the Reset dialog, reset the current corner or all four corners. When the locations and value are set, select **Reset**.
13. To save the current ECC settings, when the convergence is complete, select **Save** beside the ILS file named at the top of the panel.

# Performing a backup

After completing projector calibrations and configurations, perform a backup so the projector can be restored to the initial configuration if needed. For details on performing a backup, see the *CineLife+ 2.0 User guide* (P/N: 020-103845-XX).

# Regulatory

This product conforms to the latest regulations and standards related to product safety, environmental, and electromagnetic compatibility (EMC) requirements.

## Safety

- IEC 62368-1:2018 - Audio/Video, Information And Communication Technology Equipment - Part 1: Safety Requirements
- BS EN 62368-1:2014 - Audio/Video, Information And Communication Technology Equipment - Part 1: Safety Requirements
- UL 62368-1:2018 - Audio/Video, Information And Communication Technology Equipment - Part 1: Safety Requirements
- CSA CAN/CSA-22.2 No. 62368-1:2018 - Audio/Video, Information And Communication Technology Equipment - Part 1: Safety Requirements
- IEC 62471-5:2015 - Photobiological Safety of Lamps and Lamp Systems - Part 5: Image projectors
- IEC 60825-1:2014 - Safety of Laser Products - Part 1: Equipment Classification and Requirements
- ANSI Z136.1:2014 - Safety of Lasers
- Canada Gazette, Part 2, Volume 158, Number 21: Regulations Amending the Radiation Emitting Devices Regulations (Laser Products)

## Electro-magnetic compatibility

### Emissions

- FCC CFR47, Part 15, Subpart B, Class A – Unintentional Radiators
- CAN ICES-3 (A) / NMB-3 (A) - Information Technology Equipment (Including Digital Apparatus) - Limits and Methods of Measurement
- CISPR 32:2015+A1:2019 / EN 55032:2015+A11:2020, Class A - Electromagnetic Compatibility of Multimedia Equipment - Emission Requirements
- IEC/EN 61000-3-2: 2014 Limits for Harmonic Current Emissions
- IEC/EN 61000-3-3:2013 Limitations of Voltage Changes, Voltage Fluctuations, and Flicker

### Immunity

- CISPR 35: 2016 / EN 55035:2017+A11:2020 Electromagnetic compatibility of multimedia equipment - Immunity requirements

## California law on security

- California Law SB-327 Requiring Internet Connected Devices To Include Reasonable Security Features (California Civil Code Section 1798.91.04)

## Environmental

- China Ministry of Information Industry (along with 7 other Government Agencies) Order No.32 (01/2016) on the control of pollution caused by electronic information products, hazardous substances concentration limits (GB/T 26572 - 2011), and the applicable product marking requirement (SJ/T 11364 - 2014).
- EU Directive (2011/65/EU) on the restriction of the uses of certain hazardous substances (RoHS) in electrical and electronic equipment and the applicable official amendment(s).
- EU Directive (2012/19/EU) on waste and electrical and electronic equipment (WEEE) and the applicable official amendment(s).
- Regulation (EC) No. 1907/2006 on the registration, evaluation, authorization and restriction of chemicals (REACH) and the applicable official amendment(s).

International packaging recycling mark requirements.

- EU Directive (2012/19/EU) on waste and electrical and electronic equipment (WEEE) and the applicable official amendment(s).
- EU Directive (94/62/EC) on packaging and packaging waste
- China packaging recycling mark standard (GB18455-2010)