

Christie Rack Mount Pedestal

Digital cinema projection for
exhibition and post production



Designed for easy, secure,
digital cinema projection

With the new Christie® Rack Mount Pedestal, exhibitor and post production theaters worldwide can cost-effectively streamline their digital cinema projection workflow. This next generation model features the security of a full projector attachment and the convenience of pedestal height adjustment, as well as ample storage and access to all required projection equipment and cables.

CHRISTIE®

Christie Rack Mount Pedestal for Christie Solaria Series 2 projectors

108-416102-01

Christie's Rack Mount Pedestal completes an end-to-end, high-performance and cost-effective digital cinema projection display system from a single-source manufacturer.



- ▲ For additional safety easily secure the four projector feet
- ▶ Conveniently store the light power supply (LPS) inside the rack



When installing digital cinema equipment, maximize your available space with the next generation of Christie's pedestal, for the most secure projector installation, easy visual data monitoring and management, and convenient equipment storage and access.

Cost-effective versatility and safety, featuring adjustable stand height to suit varying port holes, easy to move and position projector with casters, and secure projector installation with four foot-lock brackets

Delivers streamlined workflow and space requirements for equipment with up to 30 RU of rack space (12 RU with Lamp Power Supply (LPS) installed) and can be configured into a side-rack mount option as well

Engineered specifically for Christie Solaria™ Series 2 projectors, the new Christie pedestal provides easy power cable storage and access resulting in efficient and safe work environments

Underwriters Laboratory (UL) tested for high performance and secure projection workflow

Specifications					
Projector mounting	<ul style="list-style-type: none"> • Top pedestal mounting for all Christie Solaria Series and DLP Cinema® projectors • Internal mounting of LPS for CP2230/CP4230 				
Height	<table border="0"> <tr> <td>installation height</td> <td> <ul style="list-style-type: none"> • Variable projector center-lens installation height ranges include: Adjustable height range: 43.0-54.8" (1092.5-1391.5mm) Minimum (without casters): 43.0" (1092.5mm) Minimum (with casters): 44.9" (1141.5mm) Maximum 54.8" (1391.5mm) </td> </tr> <tr> <td>physical height</td> <td> <ul style="list-style-type: none"> • Adjustable height (without casters): 33-40.6" (840-1032mm) • Adjustable height (with casters): 34.5-40.6" (876-1032mm) </td> </tr> </table>	installation height	<ul style="list-style-type: none"> • Variable projector center-lens installation height ranges include: Adjustable height range: 43.0-54.8" (1092.5-1391.5mm) Minimum (without casters): 43.0" (1092.5mm) Minimum (with casters): 44.9" (1141.5mm) Maximum 54.8" (1391.5mm) 	physical height	<ul style="list-style-type: none"> • Adjustable height (without casters): 33-40.6" (840-1032mm) • Adjustable height (with casters): 34.5-40.6" (876-1032mm)
installation height	<ul style="list-style-type: none"> • Variable projector center-lens installation height ranges include: Adjustable height range: 43.0-54.8" (1092.5-1391.5mm) Minimum (without casters): 43.0" (1092.5mm) Minimum (with casters): 44.9" (1141.5mm) Maximum 54.8" (1391.5mm) 				
physical height	<ul style="list-style-type: none"> • Adjustable height (without casters): 33-40.6" (840-1032mm) • Adjustable height (with casters): 34.5-40.6" (876-1032mm) 				
Width	• 26.6" (676mm)				
Length	• 40.7" (1034mm)				
Weight	• 154lbs (70kg)				
Rack	<ul style="list-style-type: none"> • Up to 30 RU of space for rack mounted accessories. (12RU with LPS installed) 				
Accessories	<ul style="list-style-type: none"> • Supports commonly installed components including the Christie Act theater automation solution and other third party accessories 				

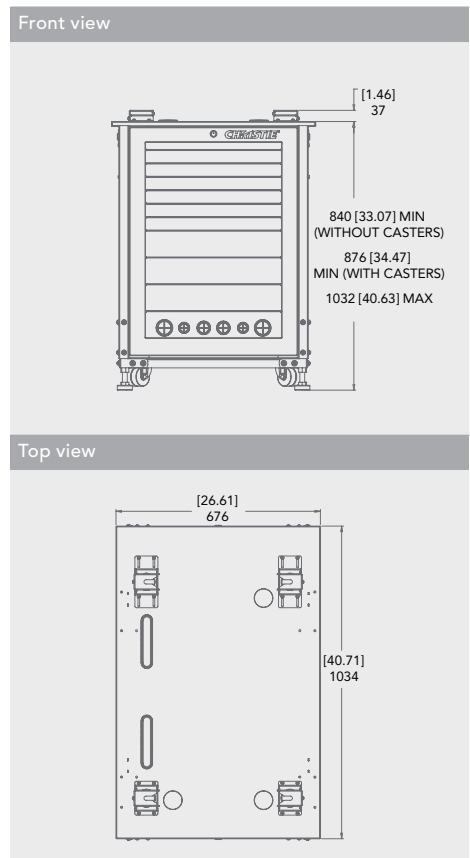

Corporate offices

Christie Digital Systems USA, Inc
USA – Cypress
ph: 714 236 8610

Christie Digital Systems Canada Inc.
Canada – Kitchener
ph: 519 744 8005

Worldwide offices

United Kingdom
ph: +44 (0) 118 977 8000

Germany
ph: +49 2161 664540

France
ph: +33 (0) 1 41 21 44 04

Spain
ph: +34 91 633 9990

Eastern Europe and
Russian Federation
ph: +36 (0) 1 47 48 100

United Arab Emirates
ph: +971 4 3206688

India
ph: +91 80 6708 9999

Singapore
ph: +65 6877 8737

China (Shanghai)
ph: +86 21 6278 7708

China (Beijing)
ph: +86 10 6561 0240

Japan (Tokyo)
ph: 81 3 3599 7481

Korea (Seoul)
ph: +82 2 702 1601

Independent sales consultant offices

Italy
ph: +39 (0) 2 9902 1161

South Africa
ph: +27 (0) 317 671 347



For the most current specification information, please visit www.christiedigital.com

Copyright 2012 Christie Digital Systems USA, Inc. All rights reserved. All brand names and product names are trademarks, registered trademarks or tradenames of their respective holders. Christie Digital Systems Canada Inc.'s management system is registered to ISO 9001 and ISO 14001. Performance specifications are typical. Due to constant research, specifications are subject to change without notice. Printed in Canada on recycled paper. 3275 Mar 12

CHRISTIE®